



# 密封件

# SEALS

## 2022

## 液压缸应用举例

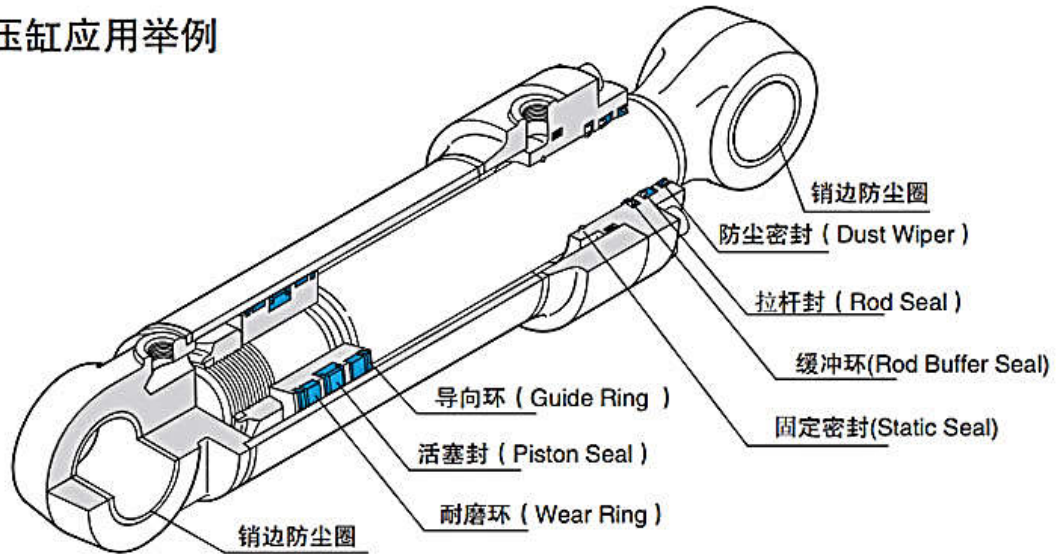

- |   |           |                             |
|---|-----------|-----------------------------|
| A | 拉杆封       | Rod Seal                    |
| B | 缓冲环       | Rod Buffer Seal             |
| C | 单向活塞封     | Piston Seal (Single Acting) |
| D | 双向活塞封     | Piston Seal (Double Acting) |
| E | 防尘环       | Dust Wiper                  |
| F | 导向/耐磨环    | Guide Ring Wear Ring        |
| G | 固定密封(承托环) | Static Seal (Back-up Ring)  |
| H | 旋转密封      | Rotary Shaft Seal           |
| I | 销边防尘圈     | Pin Dust Wiper              |
| J | 骨架油封      | Oil Seal                    |
| K | 其他        | Others                      |

用途 Function	型号 Type	截面图 Profile	品牌 Brand	材质 Material	页码 Page
D	SPW			PTFE+NBR+NY 四氟+丁腈橡胶+尼 龙	1
D	PGR			PTFE+NBR 四氟+丁腈橡胶	2~3
D	SPG			PTFE+NBR 四氟+丁腈橡胶	4
D	SPA			NY+NBR 尼龙+丁腈橡胶	5
D	NCF5			PTFE+NY+NBR 四氟+尼龙+丁腈橡 胶	6
D	NCF3			NY+NBR 尼龙+丁腈橡胶	7
D	MHM			POM+NBR 聚甲醛+丁腈橡胶	8
D	OHS			POM+NBR 聚甲醛+丁腈橡胶	9
D	TLM			POM+NBR 聚甲醛+丁腈橡胶	10~11
D	SOK			NY+NBR 尼龙+丁腈橡胶	12
D	PKR			PU+NBR 聚氨酯+丁腈橡胶	13
C	OUS			NY+PU 尼龙+聚氨酯	14
C	OUYH			POM+PU 聚甲醛+聚氨酯	15

用途 Function	型号 Type	截面图 Profile	品牌 Brand	材质 Material	页码 Page
D	754		HALLITE	PU+NBR 聚氨酯+丁腈橡胶	16
A	UIS			PU 聚氨酯	17~18
A	IRS			PU+NBR 聚氨酯+丁腈橡胶	19~20
A	UBS			PU 聚氨酯	21~22
A	RUH			HNBR 氢化丁腈橡胶	23~24
A	IRD			PU+NBR+NY 聚氨酯+丁腈橡胶+ 尼龙	25
A	MGM			POM+NBR 聚甲醛+丁腈橡胶	26
A	H605		HALLITE	PU 聚氨酯	27~30
B	RST			PTFE+NBR 四氟+丁腈橡胶	31~32
B	HBS			PU+POM 聚氨酯+聚甲醛	33
B	HBB			PU 聚氨酯	34
B	HBU			PU+POM 聚氨酯+聚甲醛	35
E	DKS			NBR+IRON 丁腈橡胶+铁	36

用途 Function	型号 Type	截面图 Profile	品牌 Brand	材质 Material	页码 Page
E	DKP			PU+IRON 聚氨酯+铁	37
E	DGA			NBR+IRON 丁腈橡胶+铁	38~39
E	DSYK			PU 聚氨酯	39
E	DSYP			PU 聚氨酯	40
E	DSYG			PU 聚氨酯	41
E	DSP			PU 聚氨酯	42
E	DSEG			PU 聚氨酯	43~44
E	DSEK			PU 聚氨酯	45
E	DLI			PU+IRON 聚氨酯+铁	46~47
E	H38		HALLITE	PU 聚氨酯	48~49
E	H839		HALLITE	PU 聚氨酯	50
F	WR			PHENOLIC 酚醛树脂	51~53
F	KZS			PTFE 四氟	54~55

用途 Function	型号 Type	截面图 Profile	品牌 Brand	材质 Material	页码 Page
F	RYR			PTFE 四氟	56
F	GYR			RESIN FABRIC 酚醛夹布	57
F	506		HALLITE	RESIN FABRIC 酚醛夹布	58~68
G	N4B			PHENOLIC 酚醛树脂	69
H	ROS			PU 聚氨酯	70
H	80		HALLITE	PU 聚氨酯	71
H	SPN			PTFE+NBR 四氟+丁腈橡胶	72
H	GRS			PTFE+NBR 四氟+丁腈橡胶	73
G	N4W			NY 尼龙	74
G	BRT-NY			NY 尼龙	75
G	O-RING			NBR 丁腈橡胶	76~80
G	BRTO			PTFE 四氟	81~82
G	BRON			NBR 丁腈橡胶	83~85

用途 Function	型号 Type	截面图 Profile	品牌 Brand	材质 Material	页码 Page
F	DU			STEEL+PTFE/LEAD OVERLAY 钢+四氟/铝涂层	86~87
G	DRN			NBR 丁腈橡胶	88
G	DRP			PU 聚氨酯	89
5	VA			NBR 丁腈橡胶	90
I	VAY			NBR+IRON 丁腈橡胶+铁	91
H	OIL SEAL			RUBBER+IRON 橡胶+铁	92~94
K	TBR			PTFE+NBR 四氟+丁腈橡胶	95
K	VALVE SEAL			RUBBER/PU/IRON 橡胶/聚氨酯/铁	96
K	IUT			PTFE 四氟	97
K	OUT			PTFE 四氟	98~99
K	STEEL RING			STEEL 钢	100
K	COPPER RING			COPPER 铜	101
K	COUPLING				102~107

用途 Function	型号 Type	截面图 Profile	品牌 Brand	材质 Material	页码 Page
AC	601		HALLITE	PU 聚氨酯	108~110
A	622		HALLITE	PU+NBR 聚氨酯+丁腈橡胶	111
B	660		HALLITE	PU+POM 聚氨酯+聚甲醛	112
D	780		HALLITE	POM+NY+NBR 聚甲醛+尼龙+丁腈 橡胶	113~114
K	CAT INCH CTC-SPG				115
K	CAT INCH CTC-SPA				116
K	CAT INCH CTC-UBS				117
K	CAT INCH CTC-DLI				118
K	CAT INCH CTC-HBI				119
K	CAT INCH CTC-HBS				120
K	CAT INCH CTC-DLC				121
K	CAT INCH CTC-DKC				122
K	CAT INCH CTC-WRA				123~124



用途 Function	型号 Type	截面图 Profile	品牌 Brand	材质 Material	页码 Page
K	CAT INCH CTC-HBC				125
K	CAT INCH CTC-DRN				126
K	CAT INCH OTHERS				127
K	O RING KIT				128

# SPW (SPGW MCPS)

## 活塞密封 PISTON SEAL



Material  
材质

PTFE+NBR+NY  
四氟+丁腈橡胶+尼龙

编号 Part No.	外径 øD	内径 ød	高度 h	槽宽 L
SPW 50	50	36	8.5	9
SPW 55	55	41	8.5	9
SPW 60	60	46	8.5	9
SPW 63	63	49	8.5	9
SPW 65	65	50	10.5	11
SPW 70	70	55	10.5	11
SPW 75	75	60	10.5	11
SPW 80	80	65	10.5	11
SPW 85	85	70	10.5	11
SPW 90	90	75	10.5	11
SPW 95	95	80	10.5	11
SPW 100	100	85	12	12.5
SPW 105	105	90	12	12.5
SPW 110	110	95	12	12.5
SPW 115	115	100	12	12.5
SPW 120	120	105	12	12.5
SPW 125	125	102	15.5	16
SPW 130	130	107	15.5	16
SPW 135	135	112	15.5	16
SPW 140	140	117	15.5	16
SPW 145	145	122	15.5	16
SPW 150	150	127	15.5	16
SPW 155	155	132	15.5	16
SPW 160	160	137	15.5	16
SPW 165	165	142	15.5	16
SPW 170	170	147	15.5	16
SPW 175	175	152	15.5	16
SPW 180	180	157	15.5	16
SPW 185	185	162	15.5	16
SPW 190	190	167	15.5	16

编号 Part No.	外径 øD	内径 ød	高度 h	槽宽 L
SPW 195	195	172	15.5	16
SPW 200	200	177	15.5	16
SPW 210	210	187	15.5	16
SPW 215	215	192	15.5	16
SPW 220	220	197	15.5	16
SPW 225	225	202	15.5	16
SPW 230	230	207	15.5	16
SPW 240	240	217	15.5	16
SPW 250	250	222	17	17.5
SPW 260	260	232	17	17.5
SPW 270	270	242	17	17.5
SPW 280	280	252	17	17.5
SPW 290	290	262	17	17.5
SPW 300	300	272	17	17.5
SPW 310	310	282	17	17.5
SPW 320	320	292	17	17.5
SPW 330	330	302	17	17.5
SPW 340	340	312	17	17.5
SPW 350	350	322	17	17.5
SPW-110A	110	93	10.5	
SPW-120A	120	100	15.5	
SPW-130A	130	115	12	
SPW-160A	160	145	12	
SPW-190A	190	175	12	
SPV-150	150	135	14/18	
SPV-170	170	155	14/18	
SPV-190	190	175	14/18	
SPV-230				
SPV-250	250	230	17/21	
SPV-260	260	240	17/21	

# PGR (MPS Glydring SPGO D-Seal)

## 活塞密封



Material  
材质

PTFE+NBR  
四氟+丁腈橡胶

编号 Part No.	外径 øD	内径 ød	高度 h	槽宽 L
PGR-16-3.2	16	8.5	3	3.2
PGR-18-3.2	18	10.5	3	3.2
PGR-21-3.2	21	13.5	3	3.2
PGR-22-3.2	22	14.5	3	3.2
PGR-25-3.2	25	17.5	3	3.2
PGR-28-3.2	28	20.5	3	3.2
PGR-30-3.2	30	22.5	3	3.2
PGR-35-3.2	35	27.5	3	3.2
PGR-38-3.2	38	30.5	3	3.2
PGR-40-3.2	40	32.5	3	3.2
PGR-45-3.2	45	37.5	3	3.2
PGR-50-3.2	50	42.5	3	3.2
PGR-25-4.2	25	14	4	4.2
PGR-28-4.2	28	17	4	4.2
PGR-30-4.2	30	19	4	4.2
PGR-32-4.2	32	21	4	4.2
PGR-35-4.2	35	24	4	4.2
PGR-36-4.2	36	25	4	4.2
PGR-40-4.2	40	29	4	4.2
PGR-45-4.2	45	34	4	4.2
PGR-48-4.2	48	37	4	4.2
PGR-50-4.2	50	39	4	4.2
PGR-52-4.2	52	41	4	4.2
PGR-53-4.2	53	42	4	4.2
PGR-55-4.2	55	44	4	4.2
PGR-57-4.2	57	46	4	4.2
PGR-58-4.2	58	47	4	4.2
PGR-60-4.2	60	49	4	4.2
PGR-62-4.2	62	51	4	4.2
PGR-63-4.2	63	52	4	4.2

编号 Part No.	外径 øD	内径 ød	高度 h	槽宽 L
PGR-65-4.2	65	54	4	4.2
PGR-70-4.2	70	59	4	4.2
PGR-75-4.2	75	64	4	4.2
PGR-80-4.2	80	69	4	4.2
PGR-85-4.2	85	74	4	4.2
PGR-90-4.2	90	79	4	4.2
PGR-100-4.2	100	89	4	4.2
PGR-110-4.2	110	99	4	4.2
PGR-115-4.2	115	104	4	4.2
PGR-120-4.2	120	109	4	4.2
PGR-125-4.2	125	114	4	4.2
PGR-130-4.2	130	119	4	4.2
PGR-132-4.2	132	121	4	4.2
PGR-140-4.2	140	129	4	4.2
PGR-40-6.3	40	24.5	6.1	6.3
PGR-45-6.3	45	29.5	6.1	6.3
PGR-50-6.3	50	34.5	6.1	6.3
PGR-55-6.3	55	39.5	6.1	6.3
PGR-60-6.3	60	44.5	6.1	6.3
PGR-63-6.3	63	44.5	6.1	6.3
PGR-65-6.3	65	49.5	6.1	6.3
PGR-70-6.3	70	54.5	6.1	6.3
PGR-75-6.3	75	59.5	6.1	6.3
PGR-80-6.3	80	64.5	6.1	6.3
PGR-82.5-6.3	82.5	67	6.1	6.3
PGR-85-6.3	85	69.5	6.1	6.3
PGR-90-6.3	90	74.5	6.1	6.3
PGR-95-6.3	95	79.5	6.1	6.3
PGR-100-6.3	100	84.5	6.1	6.3
PGR-101.6-6.3	101.6	86.1	6.1	6.3

# PGR (MPS Glydring SPGO D-Seal)

活塞密封

PISTON SEAL

编号 Part No.	外径 øD	内径 ød	高度 h	槽宽 l
PGR-105-6.3	105	89.5	6.1	6.3
PGR-108-6.3	108	92.5	6.1	6.3
PGR-110-6.3	110	94.5	6.1	6.3
PGR-115-6.3	115	99.5	6.1	6.3
PGR-120-6.3	120	104.5	6.1	6.3
PGR-125-6.3	125	109.5	6.1	6.3
PGR-127-6.3	127	111.5	6.1	6.3
PGR-130-6.3	130	114.5	6.1	6.3
PGR-135-6.3	135	119.5	6.1	6.3
PGR-140-6.3	140	124.5	6.1	6.3
PGR-145-6.3	145	129.5	6.1	6.3
PGR-150-6.3	150	134.5	6.1	6.3
PGR-160-6.3	160	144.5	6.1	6.3
PGR-175-6.3	175	159.5	6.1	6.3
PGR-180-6.3	180	164.5	6.1	6.3
PGR-185-6.3	185	169.5	6.1	6.3
PGR-190-6.3	190	174.5	6.1	6.3
PGR-195-6.3	195	179.5	6.1	6.3
PGR-200-6.3	200	184.5	6.1	6.3
PGR-230-6.3	230	214.5	6.1	6.3
PGR-250-6.3	250	234.5	6.1	6.3
PGR-60-8.1	60	39	7.9	8.1
PGR-65-8.1	65	44	7.9	8.1
PGR-70-8.1	70	49	7.9	8.1
PGR-75-8.1	75	54	7.9	8.1
PGR-80-8.1	80	59	7.9	8.1
PGR-85-8.1	85	64	7.9	8.1
PGR-90-8.1	90	69	7.9	8.1
PGR-95-8.1	95	74	7.9	8.1
PGR-100-8.1	100	79	7.9	8.1
PGR-105-8.1	105	84	7.9	8.1
PGR-110-8.1	110	89	7.9	8.1
PGR-115-8.1	115	94	7.9	8.1
PGR-120-8.1	120	99	7.9	8.1
PGR-125-8.1	125	104	7.9	8.1
PGR-130-8.1	130	109	7.9	8.1
PGR-135-8.1	135	114	7.9	8.1
PGR-140-8.1	140	119	7.9	8.1
PGR-145-8.1	145	124	7.9	8.1
PGR-150-8.1	150	129	7.9	8.1
PGR-155-8.1	155	134	7.9	8.1
PGR-160-8.1	160	139	7.9	8.1
PGR-165-8.1	165	144	7.9	8.1
PGR-170-8.1	170	149	7.9	8.1
PGR-175-8.1	175	154	7.9	8.1
PGR-180-8.1	180	159	7.9	8.1
PGR-185-8.1	185	164	7.9	8.1
PGR-190-8.1	190	169	7.9	8.1
PGR-195-8.1	195	174	7.9	8.1
PGR-200-8.1	200	179	7.9	8.1
PGR-205-8.1	205	184	7.9	8.1
PGR-210-8.1	210	189	7.9	8.1

编号 Part No.	外径 øD	内径 ød	高度 h	槽宽 l
PGR-220-8.1	220	199	7.9	8.1
PGR-225-8.1	225	204	7.9	8.1
PGR-230-8.1	230	209	7.9	8.1
PGR-240-8.1	240	219	7.9	8.1
PGR-250-8.1	250	229	7.9	8.1
PGR-260-8.1	260	239	7.9	8.1
PGR-270-8.1	270	249	7.9	8.1
PGR-280-8.1	280	259	7.9	8.1
PGR-290-8.1	290	269	7.9	8.1
PGR-300-8.1	300	279	7.9	8.1
PGR-310-8.1	310	289	7.9	8.1
PGR-320-8.1	320	299	7.9	8.1
PGR-325-8.1	325	300.5	7.9	8.1
PGR-330-8.1	330	309	7.9	8.1
PGR-335-8.1	335	310.5	7.9	8.1
PGR-345-8.1	345	320.5	7.9	8.1
PGR-355-8.1	355	330.5	7.9	8.1
PGR-360-8.1	360	339	7.9	8.1
PGR-365-8.1	365	340.5	7.9	8.1
PGR-380-8.1	380	355.5	7.9	8.1
PGR-390-8.1	390	365.5	7.9	8.1
PGR-415-8.1	415	390.5	7.9	8.1
PGR-490-8.1	490	465.5	7.9	8.1
PGR-520-8.1	520	495.5	7.9	8.1
PGR-530-8.1	530	505.5	7.9	8.1
PGR-540-8.1	540	515.5	7.9	8.1
PGR-550-8.1	550	525.5	7.9	8.1
PGR-560-8.1	560	535.5	7.9	8.1
PGR-565-8.1	565	540.5	7.9	8.1
PGR-580-8.1	580	555.5	7.9	8.1
PGR-600-8.1	600	575.5	7.9	8.1
PGR-640-8.1	640	615.5	7.9	8.1
PGR-660-8.1	660	635.5	7.9	8.1

# SPG

## 活塞密封

## PISTON SEAL



Material  
材质

PTFE+NBR  
四氟+丁腈橡胶

编号 Part No.	外径 øD	内径 ød	高度 h	槽宽 L
SPG-40-4.3	40	30	4.3	4.5
SPG-45-4.3	45	35	4.3	4.5
SPG-50-4.3	50	40	4.3	4.5
SPG-55-4.3	55	45	4.3	4.5
SPG-60-4.3	60	50	4.3	4.5
SPG-65-4.3	65	55	4.3	4.5
SPG-60-7.3	60	45	7.3	7.5
SPG-63-7.3	63	48	7.3	7.5
SPG-65-7.3	65	50	7.3	7.5
SPG-70-7.3	70	55	7.3	7.5
SPG-75-7.3	75	60	7.3	7.5
SPG-80-7.3	80	65	7.3	7.5
SPG-85-7.3	85	70	7.3	7.5
SPG-90-7.3	90	75	7.3	7.5
SPG-95-7.3	95	80	7.3	7.5
SPG-100-7.3	100	85	7.3	7.5
SPG-105-7.3	105	90	7.3	7.5
SPG-110-7.3	110	94	7.3	7.5
SPG-112-7.3	112	96	7.3	7.5
SPG-115-7.3	115	99	7.3	7.5
SPG-120-7.3	120	104	7.3	7.5
SPG-125-7.3	125	109	7.3	7.5
SPG-130-7.3	130	114	7.3	7.5
SPG-135-7.3	135	119	7.3	7.5
SPG-140-7.3	140	124	7.3	7.5
SPG-145-7.3	145	129	7.3	7.5
SPG-150-7.3	150	134	7.3	7.5
SPG-155-7.3	155	139	7.3	7.5
SPG-160-7.3	160	144	7.3	7.5

编号 Part No.	外径 øD	内径 ød	高度 h	槽宽 L
SPG-200-10.8	200	178	10.8	11
SPG-220-10.8	220	198	10.8	11
SPG-225-10.8	225	203	10.8	11
SPG-50-4.9	50	39	4.9	5.1
SPG-70-4.9	70	59	4.9	5.1
SPG-80-4.9	80	69	4.9	5.1

# SPA (SPGA)

## 活塞密封 PISTON SEAL



**Material  
材质**

**NY+NBR  
尼龙+丁腈橡胶**

编号 Part No.	外径 øD	内径 ød	高度 h	槽宽 L
SPA-90-7.3	90	74.5	7	7.3
SPA-100-7.3	100	84.5	7	7.3
SPA-105-7.3	105	89.5	7	7.3
SPA-110-7.3	110	94.5	7	7.3
SPA-115-7.3	115	99.5	7	7.3
SPA-120-7.3	120	104.5	7	7.3
SPA-130-7.3	130	114.5	7	7.3
SPA-140-9.6	140	119	9.4	9.6
SPA-150-9.6	150	129	9.4	9.6
SPA-160-9.6	160	139	9.4	9.6
SPA-170-9.6	170	149	9.4	9.6
SPA-180-9.6	180	159	9.4	9.6
SPA-190-9.6	190	169	9.4	9.6
SPA-200-9.6	200	179	9.4	9.6
SPA-210-9.6	210	189	9.4	9.6
SPA-220-9.6	220	199	9.4	9.6

编号 Part No.	外径 øD	内径 ød	高度 h	槽宽 L

# NCF5

## 活塞密封 PISTON SEAL

### Material 材质

PTFE+NY+NBR  
四氟+尼龙+丁腈橡胶

编号 Part No.	外径 øD	内径 ød	槽宽1 L1	槽宽2 L2	总高 L
NCF5-63	63	50	22	7.95	37.9
NCF5-70	70	58	22	7.95	37.9
NCF5-80	80	68	22	7.95	37.9
NCF5-90	90	78	22	7.95	37.9
NCF5-100	100	88	22	9.95	41.9
NCF5-110	110	98	22	9.95	41.9
NCF5-120	120	108	22	9.95	41.9

编号 Part No.	外径 øD	内径 ød	槽宽1 L1	槽宽2 L2	总高 L

# NCF3

## 活塞密封 PISTON SEAL



编号 Part No.	外径 øD	内径 ød	槽宽1 L1	槽宽2 L2	总高 L
NCF3-50	50	38	20.5	4.2	28.9
NCF3-60	60	48	20.5	4.2	28.9
NCF3-63	63	50	20.5	4.2	28.9
NCF3-70	70	58	20.5	4.2	28.9
NCF3-80	80	68	22.5	5.2	32.9
NCF3-85	85	71	22.5	5.2	32.9
NCF3-90	90	78	22.5	5.2	32.9
NCF3-100	100	88	22.5	5.2	32.9
NCF3-110	110	98	22.5	5.2	32.9
NCF3-120	120	108	22.5	5.2	32.9

编号 Part No.	外径 øD	内径 ød	槽宽1 L1	槽宽2 L2	总高 L



# MHM (MHM-E SPME)

## 活塞密封

## PISTON SEAL



编号 Part No.	外径 øD	内径 ød	槽宽 h
MHM-60	60	45	22.5
MHM-70	70	55	22.5
MHM-80	80	65	22.5
MHM-90	90	70	30
MHM-100	100	80	30
MHM-110	110	90	30

编号 Part No.	外径 øD	内径 ød	高度 h

# OHS (OHM)

## 活塞密封 PISTON SEAL

编号 Part No.	外径 øD	内径 ød	槽宽 h
OHS-55	55	37	12.1
OHS-60	60	42	12.1
OHS-65	65	47	12.1
OHS-70	70	48	14.5
OHS-80	80	58	14.5
OHS-85	85	63	14.5
OHS-90	90	68	14.5
OHS-100	100	78	14.5
OHS-110	110	88	14.5
OHS-115	115	93	14.5
OHS-120	120	98	14.5
OHS-125	125	103	14.5
OHS-130	130	108	14.5
OHS-135	135	113	14.5
OHS-140	140	118	14.5
OHS-145	145	123	14.5
OHS-150	150	128	14.5
OHS-160	160	138	14.5
OHS-170	170	148	14.5
OHS-180	180	158	14.5
OHS-190	190	168	14.5
OHS-200	200	178	14.5
OHS-225	225	203	14.5

编号 Part No.	外径 øD	内径 ød	高度 h

# TLM (H780 DAS KDAS)

活塞密封

PISTON SEAL



Material  
材质

POM+NY+NBR  
聚甲醛+尼龙+丁腈橡胶

编号 Part No.	OD B	ID A	GH D	GH1 D1	H L
TLM-25-15-12.5/4	25	15	12.5	4	20.5
TLM-25-16-13.5/2.1	25	16	13.5	2.1	17.7
TLM-30-17-15.4/6.35	30	17	15.4	6.35	28.1
TLM-30-21-13.5/2.1	30	21	13.5	2.1	17.7
TLM-32-22-12.5/4	32	22	12.5	4	20.5
TLM-32-22-15.5/2.6	32	22	15.5	2.6	20.7
TLM-32-22-16.4/6.35	32	22	16.4	6.35	29.1
TLM-35-25-15.5/2.6	35	25	15.5	2.6	20.7
TLM-35-25-16.4/6.35	35	25	16.4	6.35	29.1
TLM-40-24-18.4/6.35	40	24	18.4	6.35	31.1
TLM-40-26-15.5/2.6	40	26	15.5	2.6	20.7
TLM-40-30-12.5/4	40	30	12.5	4	20.5
TLM-40-30-16.4/6.35	40	30	16.4	6.35	29.1
TLM-40-32-15.5/3.2	40	32	15.5	3.2	21.9
TLM-45-29-18.4/6.35	45	29	18.4	6.35	31.1
TLM-45-31-15.5/2.6	45	31	15.5	2.6	20.7
TLM-45-35-16.4/6.35	45	35	16.4	6.35	29.1
TLM-45-37-15.5/3.2	45	37	15.5	3.2	21.9
TLM-50-34-18.4/6.35	50	34	18.4	6.35	31.1
TLM-50-34-20.5/3.1	50	34	20.5	3.1	26.7
TLM-50-38-20.5/4.2	50	38	20.5	4.2	28.9
TLM-55-39-18.4/6.35	55	39	18.4	6.35	31.1
TLM-55-39-20.5/3.1	55	39	20.5	3.1	26.7
TLM-60-44-18.4/6.35	60	44	18.4	6.35	31.1
TLM-60-44-20.5/3.1	60	44	20.5	3.1	26.7
TLM-60-48-20.5/4.2	60	48	20.5	4.2	28.9
TLM-63-47-18.4/6.35	63	47	18.4	6.35	31.1
TLM-63-47-19.4/6.35	63	47	19.4	6.35	32.1
TLM-63-47-20.5/3.1	63	47	20.5	3.1	26.7
TLM-63-51-20.5/4.2	63	51	20.5	4.2	28.9

编号 Part No.	OD B	ID A	GH D	GH1 D1	H L
TLM-63-53-12.5/4	63	53	12.5	4	20.5
TLM-65-49-20.5/3.1	65	49	20.5	3.1	26.7
TLM-65-50-18.4/6.35	65	50	18.4	6.35	31.1
TLM-70-50-22.4/6.35	70	50	22.4	6.35	35.1
TLM-70-54-20.5/3.1	70	54	20.5	3.1	26.7
TLM-70-55-20/5	70	55	20	5	30
TLM-70-58-20.5/4.2	70	58	20.5	4.2	28.9
TLM-75-55-22.4/6.35	75	55	22.4	6.35	35.1
TLM-75-59-20.5/3.1	75	59	20.5	3.1	26.7
TLM-80-60-22.4/6.35	80	60	22.4	6.35	35.1
TLM-80-62-22.5/3.6	80	62	22.5	3.6	29.7
TLM-80-65-20/5	80	65	20	5	30
TLM-80-66-22.5/5.2	80	66	22.5	5.2	32.9
TLM-85-65-22.4/6.35	85	65	22.4	6.35	35.1
TLM-90-70-22.4/6.35	90	70	22.4	6.35	35.1
TLM-90-72-22.5/3.6	90	72	22.5	3.6	29.7
TLM-90-76-22.5/5.2	90	76	22.5	5.2	32.9
TLM-95-75-22.4/6.35	95	75	22.4	6.35	35.1
TLM-100-75-22.4/6.35	100	75	22.4	6.35	35.1
TLM-100-80-25/6.35	100	80	25	6.35	37.7
TLM-100-82-22.5/3.6	100	82	22.5	3.6	29.7
TLM-100-85-20/5	100	85	20	5	30
TLM-100-86-20/5	100	86	20	5	30
TLM-100-86-22.5/5.2	100	86	22.5	5.2	32.9
TLM-105-80-22.4/6.35	105	80	22.4	6.35	35.1
TLM-110-85-22.4/6.35	110	85	22.4	6.35	35.1
TLM-110-92-22.5/3.6	110	92	22.5	3.6	29.7
TLM-110-96-22.5/5.2	110	96	22.5	5.2	32.9
TLM-115-90-22.4/6.35	115	90	22.4	6.35	35.1
TLM-115-97-22.5/3.6	115	97	22.5	3.6	29.7

# TLM (H780 DAS KDAS)

## 活塞密封

### PISTON SEAL

编号 Part No	OD R	ID A	GH D	GH1 D1	H I
TLM-120-95-22.4/6.35	120	95	22.4	6.35	35.1
TLM-120-106-22.5/5.2	120	106	22.5	5.2	32.9
TLM-125-100-25.4/6.35	125	100	25.4	6.35	38.1
TLM-125-103-26.5/5.1	125	103	26.5	5.1	36.7
TLM-125-105-25/6.35	125	105	25	6.35	37.7
TLM-125-105-25.4/6.35	125	105	25.4	6.35	38.1
TLM-125-108-26.5/7.2	125	108	26.5	7.2	40.9
TLM-130-105-25.4/6.35	130	105	25.4	6.35	38.1
TLM-130-105-25.4/9.5	130	105	25.4	9.5	44.4
TLM-135-110-25.4/6.35	135	110	25.4	6.35	38.1
TLM-135-110-25.4/9.5	135	110	25.4	9.5	44.4
TLM-140-115-25.4/6.35	140	115	25.4	6.35	38.1
TLM-140-115-25.4/9.5	140	115	25.4	9.5	44.4
TLM-140-118-26.5/5.1	140	118	26.5	5.1	36.7
TLM-140-123-26.5/7.2	140	123	26.5	7.2	40.9
TLM-145-120-25.4/6.35	145	120	25.4	6.35	38.1
TLM-145-120-25.4/9.5	145	120	25.4	9.5	44.4
TLM-150-125-25.4/6.35	150	125	25.4	6.35	38.1
TLM-150-125-25.4/9.5	150	125	25.4	9.5	44.4
TLM-150-128-26.5/5.1	150	128	26.5	5.1	36.7
TLM-150-133-26.5/7.2	150	133	26.5	7.2	40.9
TLM-155-130-25.4/6.35	155	130	25.4	6.35	38.1
TLM-155-130-25.4/9.5	155	130	25.4	9.5	44.4
TLM-160-130-25.4/6.35	160	130	25.4	6.35	38.1
TLM-160-130-25.4/9.5	160	130	25.4	9.5	44.4
TLM-160-135-25.4/9.5	160	135	25.4	9.5	44.4
TLM-160-138-26.5/5.1	160	138	26.5	5.1	36.7
TLM-160-143-26.5/7.2	160	143	26.5	7.2	40.9
TLM-165-140-25.4/9.5	165	140	25.4	9.5	44.4
TLM-170-145-25.4/12.7	170	145	25.4	12.7	50.8
TLM-170-148-26.5/5.1	170	148	26.5	5.1	36.7
TLM-175-150-25.4/12.7	175	150	25.4	12.7	50.8
TLM-180-150-35.4/6.35	180	150	35.4	6.35	48.1
TLM-180-155-25.4/12.7	180	155	25.4	12.7	50.8
TLM-180-163-26.5/7.2	180	163	26.5	7.2	40.9
TLM-185-160-25.4/12.7	185	160	25.4	12.7	50.8
TLM-190-165-25.4/12.7	190	165	25.4	12.7	50.8
TLM-195-170-25.4/12.7	195	170	25.4	12.7	50.8
TLM-200-170-35.4/6.35	200	170	35.4	6.35	48.1
TLM-200-175-25.4/12.7	200	175	25.4	12.7	50.8
TLM-200-175-31.5/6.6	200	175	31.5	6.6	44.7
TLM-210-185-25.4/12.7	210	185	25.4	12.7	50.8
TLM-220-190-35.4/6.35	220	190	35.4	6.35	48.1
TLM-220-195-25.4/12.7	220	195	25.4	12.7	50.8
TLM-230-205-25.4/12.7	230	205	25.4	12.7	50.8
TLM-240-215-25.4/12.7	240	215	25.4	12.7	50.8
TLM-250-220-35.4/6.35	250	220	35.4	6.35	48.1
TLM-250-225-25.4/12.7	250	225	25.4	12.7	50.8

编号 Part No	OD R	ID A	GH D	GH1 D1	H I
TLM-260-235-35.1/12.7	260	235	35.1	12.7	60.5
TLM-280-255-25.4/12.7	280	255	25.4	12.7	50.8
TLM-300-275-25.4/12.7	300	275	25.4	12.7	50.8
TLM-320-290-25.4/12.7	320	290	25.4	12.7	50.8
TLM-320-290-35.4/9.5	320	290	35.4	9.5	54.4
TLM-320-295-25.4/12.7	320	295	25.4	12.7	50.8
TLM-360-335-25.4/12.7	360	335	25.4	12.7	50.8

# SOK (OK K501)

## 活塞密封 PISTON SEAL



**Material**  
**材质**  
NY+NBR  
尼龙+丁腈橡胶

编号 Part No.	外径 øD	内径 ød	高度 h	槽宽 L
SOK-40-4.2	40	29	4	4.2
SOK-45-4.2	45	34	4	4.2
SOK-50-4.2	50	39	4	4.2
SOK-60-4.2	60	49	4	4.2
SOK-65-4.2	65	54	4	4.2
SOK-70-4.2	70	59	4	4.2
SOK-100-4.2	100	89	4	4.2
SOK-70-8	70	49	7.8	8
SOK-75-8	75	54	7.8	8
SOK-80-8	80	59	7.8	8
SOK-85-8	85	64	7.8	8
SOK-90-8	90	69	7.8	8
SOK-95-8	95	74	7.8	8
SOK-100-8	100	79	7.8	8
SOK-105-8	105	84	7.8	8
SOK-110-8	110	89	7.8	8
SOK-115-8	115	94	7.8	8
SOK-120-8	120	99	7.8	8
SOK-125-8	125	104	7.8	8
SOK-130-8	130	109	7.8	8
SOK-135-8	135	114	7.8	8
SOK-140-8	140	119	7.8	8
SOK-145-8	145	124	7.8	8
SOK-150-8	150	129	7.8	8
SOK-160-8	160	139	7.8	8
SOK-165-8	165	144	7.8	8
SOK-170-8	170	149	7.8	8
SOK-175-8	175	154	7.8	8
SOK-180-8	180	159	7.8	8
SOK-185-8	185	164	7.8	8

编号 Part No.	外径 øD	内径 ød	高度 h	槽宽 L
SOK-190-8	190	169	7.8	8
SOK-200-8	200	179	7.8	8
SOK-220-8	220	199	7.8	8
SOK-230-8	230	209	7.8	8
SOK-250-8	250	229	7.8	8
SOK-260-8	260	239	7.8	8
SOK-55-6.3	55	39.5	6	6.3
SOK-63-6.3	63	47.5	6	6.3
SOK-70-6.3	70	54.5	6	6.3
SOK-75-6.3	75	59.5	6	6.3
SOK-80-6.3	80	64.5	6	6.3
SOK-90-6.3	90	74.5	6	6.3
SOK-100-6.3	100	84.5	6	6.3
SOK-110-6.3	110	94.5	6	6.3
SOK-120-6.3	120	104.5	6	6.3
SOK-125-6.3	125	109.5	6	6.3
SOK-130-6.3	130	114.5	6	6.3
SOK-135-6.3	135	119.5	6	6.3
SOK-2.5-0.274				
SOK-2.75-0.274				

# PKR (KR K84 K49)

## 活塞密封 PISTON SEAL



编号 Part No.	外径 øD	内径 ød	槽宽 L
PKR-32-4.2	32	24.5	4.2
PKR-40-4.2	40	29	4.2
PKR-45-4.2	45	34	4.2
PKR-50-4.2	50	39	4.2
PKR-55-4.2	55	44	4.2
PKR-60-4.2	60	49	4.2
PKR-63-4.2	63	52	4.2
PKR-70-4.2	70	59	4.2
PKR-75-4.2	75	64	4.2
PKR-80-4.2	80	69	4.2
PKR-40-6.3	40	24.5	6.3
PKR-50-6.3	50	34.5	6.3
PKR-55-6.3	55	39.5	6.3
PKR-60-6.3	60	44.5	6.3
PKR-63-6.3	63	47.5	6.3
PKR-65-6.3	65	49.5	6.3
PKR-70-6.3	70	54.5	6.3
PKR-75-6.3	75	59.5	6.3
PKR-80-6.3	80	64.5	6.3
PKR-85-6.3	85	69.5	6.3
PKR-90-6.3	90	74.5	6.3
PKR-95-6.3	95	79.5	6.3
PKR-100-6.3	100	84.5	6.3
PKR-105-6.3	105	84.5	6.3
PKR-110-6.3	110	94.5	6.3
PKR-120-6.3	120	104.5	6.3
PKR-125-6.3	125	109.5	6.3
PKR-80-8.1	80	59	8.1
PKR-85-8.1	85	64	8.1
PKR-90-8.1	90	69	8.1
PKR-100-8.1	100	79	8.1

编号 Part No.	外径 øD	内径 ød	槽宽 L
PKR-110-8.1	110	89	8.1
PKR-115-8.1	115	94	8.1
PKR-120-8.1	120	99	8.1
PKR-125-8.1	125	104	8.1
PKR-130-8.1	130	109	8.1
PKR-140-8.1	140	119	8.1
PKR-160-8.1	160	139	8.1
PKR-180-8.1	180	159	8.1
PKR-200-8.1	200	179	8.1
PKR-80-10.5	80	59	10.5
PKR-90-10.5	90	69	10.5
PKR-110-10.5	110	89	10.5
PKR-120-10.5	120	99	10.5
PKR-125-10.5	125	104	10.5
PKR-140-10.5	140	119	10.5
PKR-150-10.5	150	129	10.5
PKR-140-12.5	140	119	12.5
PKR-200-12.5	200	175	12.5
PKR-40-6.3A	40	27	6.3
PKR-45-6.3A	45	32	6.3
PKR-50-6.3A	50	37	6.3
PKR-58-6.3A	58	45	6.3
PKR-63-6.3A	63	50	6.3
PKR-65-6.3A	65	52	6.3
PKR-65-6.3A	65	54	6.3
PKR-70-6.3A	70	57	6.3
PKR-75-6.3A	75	62	6.3
PKR-80-6.3A	80	66.5	6.3
PKR-85-6.3A	85	71.5	6.3
PKR-100-6.3A	100	86.5	6.3
PKR-105-6.3A	105	89.5	6.3

# OUS (OUY)

## 活塞密封 PISTON SEAL

**Material  
材质**

NY+NBR  
尼龙+丁腈橡胶

编号 Part No.	OD B	ID A	H C
OUS-56-30-15.5	56	30	15.5
OUS-60-35-15.5	60	35	15.5
OUS-60-45-15.5	60	45	15.5
OUS-70-45-15.5	70	45	15.5
OUS-70-55-10.5	70	55	10.5
OUS-80-55-18	80	55	18
OUS-90-65-18	90	65	18
OUS-100-75-18	100	75	18
OUS-110-85-18	110	85	18
OUS-40-25-12	40	25	12
OUS-45-30-12	45	30	12
OUS-50-35-12	50	35	12
OUS-55-40-12	55	40	12
OUS-60-45-12	60	45	12
OUS-65-50-12	65	50	12
OUS-70-55-12	70	55	12
OUS-75-60-12	75	60	12
OUS-80-65-12	80	65	12
OUS-85-70-12	85	70	12
OUS-95-80-12	95	80	12

编号 Part No.	OD B	ID A	H C

OUI

活塞密封  
PISTON SEAL

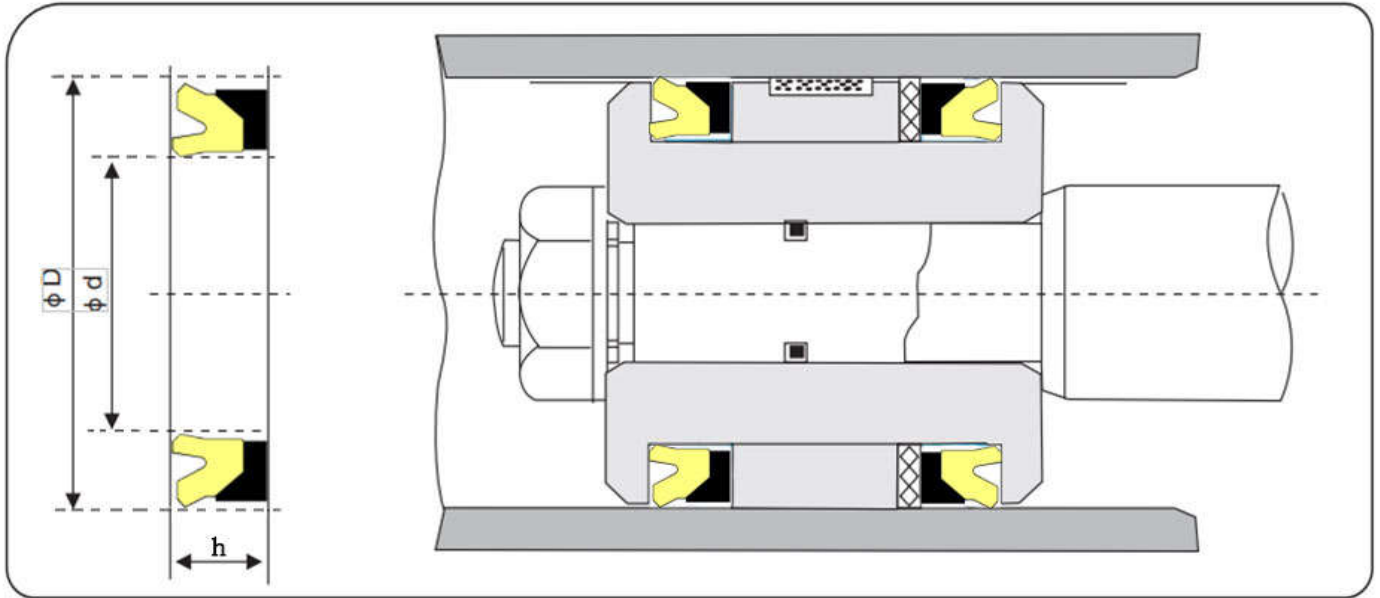

编号 Part No.	OD øD	ID ød	H h
OUIH-50-35-12	50	35	12
OUIH-55-40-12	55	40	12
OUIH-60-45-12	60	45	12
OUIH-65-50-12	65	50	12
OUIH-70-55-12	70	55	12
OUIH-75-60-12	75	60	12
OUIH-80-65-12	80	65	12
OUIH-85-70-12	85	70	12
OUIH-95-80-12	95	80	12

编号 Part No.	OD øD	ID ød	H h



# PHT (H754)

BRAND: HALLITE

## 活塞密封 PISTON SEAL

**Material  
材质**

**PU+NBR  
聚氨酯+丁腈橡胶**

编号 Part No.	OD B	ID A	GH D
PHT-30-3.2	30	22.5	3.2
PHT-32-3.2	32	24.5	3.2
PHT-35-3.2	35	27.5	3.2
PHT-40-4.2	40	29	4.2
PHT-45-4.2	45	34	4.2
PHT-50-4.2	50	39	4.2
PHT-55-4.2	55	44	4.2
PHT-60-4.2	60	49	4.2
PHT-63-4.2	63	52	4.2
PHT-65-4.2	65	54	4.2
PHT-70-4.2	70	59	4.2
PHT-75-4.2	75	64	4.2
PHT-60-6.3	60	44.5	6.3
PHT-63-6.3	63	47.5	6.3
PHT-65-6.3	65	49.5	6.3
PHT-70-6.3	70	54.5	6.3
PHT-80-6.3	80	64.5	6.3
PHT-85-6.3	85	69.5	6.3
PHT-90-6.3	90	74.5	6.3
PHT-95-6.3	95	79.5	6.3
PHT-100-6.3	100	84.5	6.3
PHT-105-6.3	105	89.5	6.3
PHT-110-6.3	110	94.5	6.3
PHT-115-6.3	115	99.5	6.3
PHT-120-6.3	120	104.5	6.3
PHT-125-6.3	125	109.5	6.3
PHT-130-6.3	130	114.5	6.3
PHT-140-6.3	140	124.5	6.3
PHT-145-6.3	145	129.5	6.3
PHT-150-6.3	150	134.5	6.3
PHT-135-8.1	135	114	8.1
PHT-140-8.1	140	119	8.1

编号 Part No.	OD B	ID A	GH D
PHT-145-8.1	145	124	8.1
PHT-150-8.1	150	129	8.1
PHT-155-8.1	155	134	8.1
PHT-160-8.1	160	139	8.1
PHT-165-8.1	165	144	8.1
PHT-170-8.1	170	149	8.1
PHT-175-8.1	175	154	8.1
PHT-180-8.1	180	159	8.1
PHT-185-8.1	185	164	8.1
PHT-190-8.1	190	169	8.1
PHT-195-8.1	195	174	8.1
PHT-200-8.1	200	179	8.1
PHT-210-8.1	210	189	8.1
PHT-220-8.1	220	199	8.1
PHT-230-8.1	230	2.9	8.1
PHT-240-8.1	240	219	8.1
PHT-250-8.1	250	229	8.1

# UIS (high quality replacement of IDI)

## 活塞杆密封

### ROD SEAL



Material  
材质

PU  
聚氨酯

编号 Part No	ID A	OD B	H C
UIS-30-40-6	30	40	6
UIS-35-45-6	35	45	6
UIS-40-50-6	40	50	6
UIS-45-55-6	45	55	6
UIS-50-60-6	50	60	6
UIS-53-63-6	53	63	6
UIS-55-65-6	55	65	6
UIS-60-70-6	60	70	6
UIS-65-75-6	65	75	6
UIS-70-80-6	70	80	6
UIS-75-85-6	75	85	6
UIS-80-90-6	80	90	6
UIS-108-118-6	108	118	6
UIS-124-134-6	124	134	6
UIS-132-142-6	132	142	6
UIS-133-143-6	133	143	6
UIS-134-144-6	134	144	6
UIS-136-146-6	136	146	6
UIS-140-150-6	140	150	6
UIS-152-162-6	152	162	6
UIS-155-165-6	155	165	6
UIS-156-166-6	156	166	6
UIS-170-180-6	170	180	6
UIS-30-40-7	30	40	7
UIS-35-45-7	35	45	7
UIS-40-50-7	40	50	7
UIS-45-55-7	45	55	7
UIS-50-60-7	50	60	7
UIS-60-70-7	60	70	7
UIS-30-40-8	30	40	8

编号 Part No	ID A	OD B	H C
UIS-35-45-8	35	45	8
UIS-40-50-8	40	50	8
UIS-45-55-8	45	55	8
UIS-50-60-8	50	60	8
UIS-55-65-8	55	65	8
UIS-60-70-8	60	70	8
UIS-65-75-8	65	75	8
UIS-70-80-8	70	80	8
UIS-80-90-8	80	90	8
UIS-40-55-9	40	55	9
UIS-45-60-9	45	60	9
UIS-50-65-9	50	65	9
UIS-55-70-9	55	70	9
UIS-60-75-9	60	75	9
UIS-65-80-9	65	80	9
UIS-70-85-9	70	85	9
UIS-75-90-9	75	90	9
UIS-80-95-9	80	95	9
UIS-85-100-9	85	100	9
UIS-90-105-9	90	105	9
UIS-95-110-9	95	110	9
UIS-98-112-9	98	112	9
UIS-100-115-9	100	115	9
UIS-105-120-9	105	120	9
UIS-110-125-9	110	125	9
UIS-115-130-9	115	130	9
UIS-120-135-9	120	135	9
UIS-125-140-9	125	140	9
UIS-130-145-9	130	145	9
UIS-135-150-9	135	150	9

## 活塞杆密封

### ROD SEAL

编号 Part No	ID A	OD B	H C
UIS-140-155-9	140	155	9
UIS-145-160-9	145	160	9
UIS-150-165-9	150	165	9
UIS-155-170-9	155	170	9
UIS-160-175-9	160	175	9
UIS-170-185-9	170	185	9
UIS-45-60-10	45	60	10
UIS-50-63-10	50	63	10
UIS-55-68-10	55	68	10
UIS-55-70-10	55	70	10
UIS-60-70-10	60	70	10
UIS-60-73-10	60	73	10
UIS-60-75-10	60	75	10
UIS-65-75-10	65	75	10
UIS-65-78-10	65	78	10
UIS-65-80-10	65	80	10
UIS-70-80-10	70	80	10
UIS-70-83-10	70	83	10
UIS-70-85-10	70	85	10
UIS-75-88-10	75	88	10
UIS-75-90-10	75	90	10
UIS-80-90-10	80	90	10
UIS-80-93-10	80	93	10
UIS-80-95-10	80	95	10
UIS-85-100-10	85	100	10
UIS-90-105-10	90	105	10
UIS-95-110-10	95	110	10
UIS-100-115-10	100	115	10
UIS-105-120-10	105	120	10
UIS-110-125-10	110	125	10
UIS-110-130-10	110	130	10
UIS-115-130-10	115	130	10
UIS-120-140-10	120	140	10
UIS-125-140-10	125	140	10
UIS-130-145-10	130	145	10
UIS-135-150-10	135	150	10
UIS-140-155-10	140	155	10
UIS-45-60-11.4	45	60	11.4
UIS-50-65-11.4	50	65	11.4
UIS-60-75-11.4	60	75	11.4
UIS-70-85-11.4	70	85	11.4
UIS-75-90-11.4	75	90	11.4
UIS-80-95-11.4	80	95	11.4
UIS-85-100-11.4	85	100	11.4
UIS-90-105-11.4	90	105	11.4

编号 Part No	ID A	OD B	H C
UIS-40-60-12	40	60	12
UIS-45-65-12	45	65	12
UIS-50-70-12	50	70	12
UIS-55-71-12	55	71	12
UIS-55-75-12	55	75	12
UIS-60-80-12	60	80	12
UIS-65-85-12	65	85	12
UIS-70-90-12	70	90	12
UIS-75-95-12	75	95	12
UIS-80-100-12	80	100	12
UIS-85-105-12	85	105	12
UIS-90-110-12	90	110	12
UIS-95-115-12	95	115	12
UIS-100-120-12	100	120	12
UIS-105-125-12	105	125	12
UIS-110-130-12	110	130	12
UIS-115-135-12	115	135	12
UIS-120-140-12	120	140	12
UIS-130-150-12	130	150	12
UIS-135-155-12	135	155	12
UIS-140-160-12	140	160	12
UIS-180-200-12	180	200	12
UIS-185-205-12	185	205	12
UIS-190-210-12	190	210	12
UIS-100-120-15	100	120	15
UIS-105-125-15	105	125	15
UIS-110-130-15	110	130	15
UIS-115-135-15	115	135	15
UIS-120-140-15	120	140	15
UIS-135-155-15	135	155	15
UIS-140-160-15	140	160	15
UIS-115-135-16	115	135	16
UIS-130-150-16	130	150	16
UIS-185-205-16	185	205	16
UIS-190-215-16	190	215	16
UIS-200-225-19	200	225	19
UIS-260-285-19	260	285	19

# IRS

## 活塞杆密封

### ROD SEAL

## Material 材质

PU+NBR  
聚氨酯+丁腈橡胶

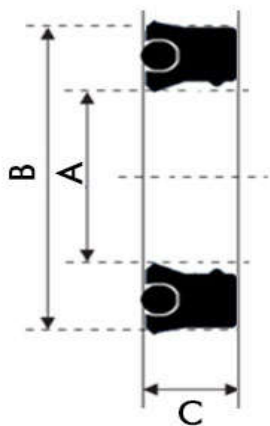

编号 Part No.	ID A	OD B	H C
IRS-30-40-6	30	40	6
IRS-35-45-6	35	45	6
IRS-40-50-6	40	50	6
IRS-40-48-6	40	48	6
IRS-45-55-6	45	55	6
IRS-50-60-6	50	60	6
IRS-55-65-6	55	65	6
IRS-60-70-6	60	70	6
IRS-65-75-6	65	75	6
IRS-70-80-6	70	80	6
IRS-75-85-6	75	85	6
IRS-80-90-6	80	90	6
IRS-30-40-7	30	40	7
IRS-35-45-7	35	45	7
IRS-40-50-7	40	50	7
IRS-45-55-7	45	55	7
IRS-50-60-7	50	60	7
IRS-60-70-7	60	70	7
IRS-65-75-7	65	75	7
IRS-70-80-7	70	80	7
IRS-30-40-8	30	40	8
IRS-35-45-8	35	45	8
IRS-40-50-8	40	50	8
IRS-45-55-8	45	55	8
IRS-50-58-8	50	58	8
IRS-50-60-8	50	60	8
IRS-55-65-8	55	65	8
IRS-60-70-8	60	70	8
IRS-65-75-8	65	75	8
IRS-70-80-8	70	80	8

编号 Part No.	ID A	OD B	H C
IRS-80-90-8	80	90	8
IRS-35-50-9	35	50	9
IRS-40-55-9	40	55	9
IRS-45-60-9	45	60	9
IRS-50-65-9	50	65	9
IRS-55-70-9	55	70	9
IRS-60-75-9	60	75	9
IRS-65-80-9	65	80	9
IRS-70-80-9	70	80	9
IRS-70-85-9	70	85	9
IRS-75-90-9	75	90	9
IRS-80-95-9	80	95	9
IRS-85-100-9	85	100	9
IRS-90-105-9	90	105	9
IRS-95-110-9	95	110	9
IRS-100-115-9	100	115	9
IRS-105-120-9	105	120	9
IRS-110-125-9	110	125	9
IRS-115-130-9	115	130	9
IRS-120-135-9	120	135	9
IRS-125-140-9	125	140	9
IRS-130-145-9	130	145	9
IRS-130-150-9	130	150	9
IRS-135-150-9	135	150	9
IRS-140-155-9	140	155	9
IRS-145-160-9	145	160	9
IRS-35-50-10	35	50	10
IRS-40-55-10	40	55	10
IRS-45-60-10	45	60	10
IRS-50-63-10	50	63	10

# IRS

## 活塞杆密封 ROD SEAL

编号 Part No	ID A	OD B	H C
IRS-50-65-10	50	65	10
IRS-55-68-10	55	68	10
IRS-55-70-10	55	70	10
IRS-60-70-10	60	70	10
IRS-60-73-10	60	73	10
IRS-60-75-10	60	75	10
IRS-60-76-10	60	76	10
IRS-65-75-10	65	75	10
IRS-65-78-10	65	78	10
IRS-65-80-10	65	80	10
IRS-70-80-10	70	80	10
IRS-70-83-10	70	83	10
IRS-70-85-10	70	85	10
IRS-75-88-10	75	88	10
IRS-75-90-10	75	90	10
IRS-80-90-10	80	90	10
IRS-80-93-10	80	93	10
IRS-80-95-10	80	95	10
IRS-85-100-10	85	100	10
IRS-90-105-10	90	105	10
IRS-95-110-10	95	110	10
IRS-100-115-10	100	115	10
IRS-105-120-10	105	120	10
IRS-110-125-10	110	125	10
IRS-110-130-10	110	130	10
IRS-115-130-10	115	130	10
IRS-120-140-10	120	140	10
IRS-130-145-10	130	145	10
IRS-135-150-10	135	150	10
IRS-140-155-10	140	155	10
IRS-145-160-10	145	160	10
IRS-160-175-10	160	175	10
IRS-45-60-11.4	45	60	11.4
IRS-50-65-11.4	50	65	11.4
IRS-60-75-11.4	60	75	11.4
IRS-70-85-11.4	70	85	11.4
IRS-75-90-11.4	75	90	11.4
IRS-80-95-11.4	80	95	11.4
IRS-85-100-11.4	85	100	11.4
IRS-90-105-11.4	90	105	11.4
IRS-35-50-12	35	50	12
IRS-40-60-12	40	60	12
IRS-45-65-12	45	65	12
IRS-50-70-12	50	70	12
IRS-55-70-12	55	70	12
IRS-55-75-12	55	75	12
IRS-60-75-12	60	75	12
IRS-60-80-12	60	80	12

编号 Part No	ID A	OD B	H C
IRS-65-80-12	65	80	12
IRS-65-85-12	65	85	12
IRS-70-80-12	70	80	12
IRS-70-85-12	70	85	12
IRS-70-90-12	70	90	12
IRS-75-95-12	75	95	12
IRS-80-95-12	80	95	12
IRS-80-100-12	80	100	12
IRS-85-100-12	85	100	12
IRS-85-105-12	85	105	12
IRS-90-105-12	90	105	12
IRS-90-110-12	90	110	12
IRS-95-110-12	95	110	12
IRS-95-115-12	95	115	12
IRS-100-120-12	100	120	12
IRS-105-125-12	105	125	12
IRS-110-130-12	110	130	12
IRS-115-135-12	115	135	12
IRS-120-140-12	120	140	12
IRS-125-145-12	125	145	12
IRS-130-150-12	130	150	12
IRS-135-155-12	135	155	12
IRS-140-160-12	140	160	12
IRS-145-165-12	145	165	12
IRS-150-170-12	150	170	12
IRS-160-180-12	160	180	12
IRS-100-120-15	100	120	15
IRS-105-125-15	105	125	15
IRS-110-130-15	110	130	15
IRS-115-135-15	115	135	15
IRS-120-140-15	120	140	15
IRS-135-155-15	135	155	15
IRS-140-160-15	140	160	15
IRS-145-165-15	145	165	15
IRS-150-170-15	150	170	15
IRS-160-180-15	160	180	15
IRS-110-130-16	110	130	16
IRS-115-135-16	115	135	16
IRS-130-150-16	130	150	16
IRS-145-165-16	145	165	16
IRS-150-170-16	150	170	16
IRS-260-285-19	260	285	19

# UBS (BS UN UNS)

## 活塞杆密封 ROD SEAL

Material  
材质

PU  
聚氨酯

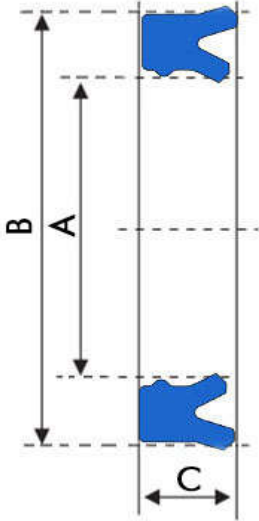

编号 Part No.	ID A	OD B	H C
UBS-30-40-6	30	40	6
UBS-30-40-7	30	40	7
UBS-30-40-8	30	40	8
UBS-35-45-6	35	45	6
UBS-35-45-7	35	45	7
UBS-35-45-7.3	35	45	7.3
UBS-35-45-8	35	45	8
UBS-38.1-47.63-6.35	38.1	47.63	6.35
UBS-40-50-6	40	50	6
UBS-40-50-7	40	50	7
UBS-40-50-8	40	50	8
UBS-40-55-9	40	55	9
UBS-40-60-12	40	60	12
UBS-44.45-53.98-6.35	44.45	53.98	6.35
UBS-45-55-6	45	55	6
UBS-45-55-7	45	55	7
UBS-45-55-8	45	55	8
UBS-45-60-9	45	60	9
UBS-45-60-10	45	60	10
UBS-45-60-11.4	45	60	11.4
UBS-45-65-12	45	65	12
UBS-50-60-6	50	60	6
UBS-50-60-7	50	60	7
UBS-50-60-8	50	60	8
UBS-50-63-10	50	63	10
UBS-50-65-9	50	65	9
UBS-50-65-11.4	50	65	11.4
UBS-50-70-12	50	70	12
UBS-50.8-63.5-9.53	50.8	63.5	9.53
UBS-53-63-6	53	63	6

编号 Part No.	ID A	OD B	H C
UBS-55-65-6	55	65	6
UBS-55-65-8	55	65	8
UBS-55-68-10	55	68	10
UBS-55-70-9	55	70	9
UBS-55-70-10	55	70	10
UBS-55-71-12	55	71	12
UBS-55-75-12	55	75	12
UBS-56-66-7.3	56	66	7.3
UBS-56-71-11.4	56	71	11.4
UBS-60-70-6	60	70	6
UBS-60-70-7	60	70	7
UBS-60-70-8	60	70	8
UBS-60-70-10	60	70	10
UBS-60-73-10	60	73	10
UBS-60-75-9	60	75	9
UBS-60-75-10	60	75	10
UBS-60-75-11.4	60	75	11.4
UBS-60-80-12	60	80	12
UBS-65-75-6	65	75	6
UBS-65-75-8	65	75	8
UBS-65-75-10	65	75	10
UBS-65-78-10	65	78	10
UBS-65-80-9	65	80	9
UBS-65-80-10	65	80	10
UBS-65-85-12	65	85	12
UBS-70-80-6	70	80	6
UBS-70-80-8	70	80	8
UBS-70-80-10	70	80	10
UBS-70-83-10	70	83	10
UBS-70-85-9	70	85	9

## 活塞杆密封

## ROD SEAL

编号 Part No	ID A	OD B	H C
UBS-70-85-10	70	85	10
UBS-70-85-11.4	70	85	11.4
UBS-70-85-12	70	85	12
UBS-70-90-12	70	90	12
UBS-75-85-6	75	85	6
UBS-75-88-10	75	88	10
UBS-75-90-9	75	90	9
UBS-75-90-10	75	90	10
UBS-75-90-11.4	75	90	11.4
UBS-75-95-12	75	95	12
UBS-80-90-6	80	90	6
UBS-80-90-8	80	90	8
UBS-80-90-10	80	90	10
UBS-80-93-10	80	93	10
UBS-80-95-9	80	95	9
UBS-80-95-10	80	95	10
UBS-80-95-11.4	80	95	11.4
UBS-80-100-12	80	100	12
UBS-85-100-9	85	100	9
UBS-85-100-10	85	100	10
UBS-85-100-11.4	85	100	11.4
UBS-85-105-12	85	105	12
UBS-90-105-9	90	105	9
UBS-90-105-10	90	105	10
UBS-90-105-11.4	90	105	11.4
UBS-90-110-12	90	110	12
UBS-95-110-9	95	110	9
UBS-95-110-10	95	110	10
UBS-95-115-12	95	115	12
UBS-100-115-9	100	115	9
UBS-100-115-10	100	115	10
UBS-100-120-12	100	120	12
UBS-100-120-15	100	120	15
UBS-105-120-9	105	120	9
UBS-105-120-10	105	120	10
UBS-105-125-12	105	125	12
UBS-105-125-15	105	125	15
UBS-110-125-9	110	125	9
UBS-110-125-10	110	125	10
UBS-110-130-10	110	130	10
UBS-110-130-12	110	130	12
UBS-110-130-15	110	130	15
UBS-115-130-9	115	130	9
UBS-115-130-10	115	130	10
UBS-115-135-12	115	135	12
UBS-115-135-15	115	135	15
UBS-115-135-16	115	135	16

编号 Part No	ID A	OD B	H C
UBS-120-135-9	120	135	9
UBS-120-140-10	120	140	10
UBS-120-140-12	120	140	12
UBS-120-140-15	120	140	15
UBS-125-140-9	125	140	9
UBS-125-140-10	125	140	10
UBS-130-145-9	130	145	9
UBS-130-145-10	130	145	10
UBS-130-150-12	130	150	12
UBS-130-150-16	130	150	16
UBS-135-150-9	135	150	9
UBS-135-150-10	135	150	10
UBS-135-155-12	135	155	12
UBS-135-155-15	135	155	15
UBS-140-155-9	140	155	9
UBS-140-155-10	140	155	10
UBS-140-160-12	140	160	12
UBS-140-160-15	140	160	15
UBS-145-160-9	145	160	9
UBS-150-165-9	150	165	9
UBS-155-170-9	155	170	9
UBS-160-175-9	160	175	9
UBS-170-185-9	170	185	9
UBS-175-190-9	175	190	9
UBS-180-200-12	180	200	12
UBS-185-205-12	185	205	12
UBS-185-205-16	185	205	16
UBS-190-210-12	190	210	12
UBS-190-215-16	190	215	16
UBS-200-225-19	200	225	19
UBS-260-285-19	260	285	19

# RUH(IUH), IKU (IUH for Komatsu)

## 活塞杆密封

## ROD SEAL



Material  
材质

NBR  
丁腈橡胶

编号 Part No.	ID A	OD B	H C
RUH-10-14-2.3	10	14	2.3
RUH-19-27-6	19	27	6
RUH-20-30-6	20	30	6
RUH-22-32-6	22	32	6
RUH-25-33-6	25	33	6
RUH-25-35-7	25	35	7
RUH-28-40-9	28	40	9
RUH-30-40-7	30	40	7
RUH-30-40-8	30	40	8
RUH-35-43-6	35	43	6
RUH-35-45-7	35	45	7
RUH-35-45-8	35	45	8
RUH-35-50-9	35	50	9
RUH-40-50-6	40	50	6
RUH-40-55-9	40	55	9
RUH-45-55-8	45	55	8
RUH-45-70-12	45	70	12
RUH-50-60-6	50	60	6
RUH-50-60-7	50	60	7
RUH-50-65-10	50	65	10
RUH-50-65-9	50	65	9
RUH-50-70-10	50	70	10
RUH-54-60-9	54	60	9
RUH-55-65-6	55	65	6
RUH-55-70-9	55	70	9
RUH-60-70-6	60	70	6
RUH-60-75-9	60	75	9
RUH-62-78-10	62	78	10
RUH-65-80-9	65	80	9
RUH-68-75-10	68	75	10

编号 Part No.	ID A	OD B	H C
RUH-70-80-6	70	80	6
RUH-70-85-9	70	85	9
RUH-70-85-10	70	85	10
RUH-75-90-9	75	90	9
RUH-80-90-6	80	90	6
RUH-80-95-10	80	95	10
RUH-80-95-9	80	95	9
RUH-85-100-9	85	100	9
RUH-85-105-12	85	105	12
RUH-90-100-6	90	100	6
RUH-90-105-9	90	105	9
RUH-90-110-12	90	110	12
RUH-95-110-9	95	110	9
RUH-95-115-12	95	115	12
RUH-100-115-9	100	115	9
RUH-100-120-12	100	120	12
RUH-105-120-10	105	120	10
RUH-105-120-9	105	120	9
RUH-105-125-12	105	125	12
RUH-110-125-10	110	125	10
RUH-110-125-9	110	125	9
RUH-110-130-12	110	130	12
RUH-115-130-10	115	130	10
RUH-115-130-9	115	130	9
RUH-115-135-12	115	135	12
RUH-120-135-9	120	135	9
RUH-120-140-12	120	140	12
RUH-125-140-9	125	140	9
RUH-130-145-9	130	145	9
RUH-130-150-12	130	150	12



# RUH(IUH), IKU (IUH for Komatsu only)

## 活塞杆密封

### ROD SEAL

编号 Part No	ID A	OD B	H C
RUH-135-150-9	135	150	9
RUH-140-155-9	140	155	9
RUH-145-160-10	145	160	10
RUH-145-160-9	145	160	9
RUH-150-165-10	150	165	10
RUH-155-170-10	155	170	10
RUH-160-175-10	160	175	10
RUH-160-180-12	160	180	12
RUH-165-180-10	165	180	10
RUH-170-190-12	170	190	12
RUH-170-195-15	170	195	15
RUH-180-200-9	180	200	9
RUH-180-205-15	180	205	15
RUH-190-210-12	190	210	12
RUH-195-215-12	195	215	12
RUH-195-215-9	195	215	9
RUH-200-220-12	200	220	12
RUH-210-230-12	210	230	12
RUH-220-240-12	220	240	12
RUH-250-270-12	250	270	12
RUH-280-305-18	280	305	18

编号 Part No	ID A	OD B	H C
IKU-50-63-10	50	63	10
IKU-55-68-10	55	68	10
IKU-60-73-10	60	73	10
IKU-65-78-10	65	78	10
IKU-70-83-10	70	83	10
IKU-75-88-10	75	88	10
IKU-80-93-10	80	93	10
IKU-85-100-10	85	100	10
IKU-90-105-10	90	105	10
IKU-95-110-10	95	110	10
IKU-100-115-10	100	115	10
IKU-110-130-10	110	130	10
IKU-120-140-10	120	140	10

# IRD (BD)

## 活塞杆密封 ROD SEAL

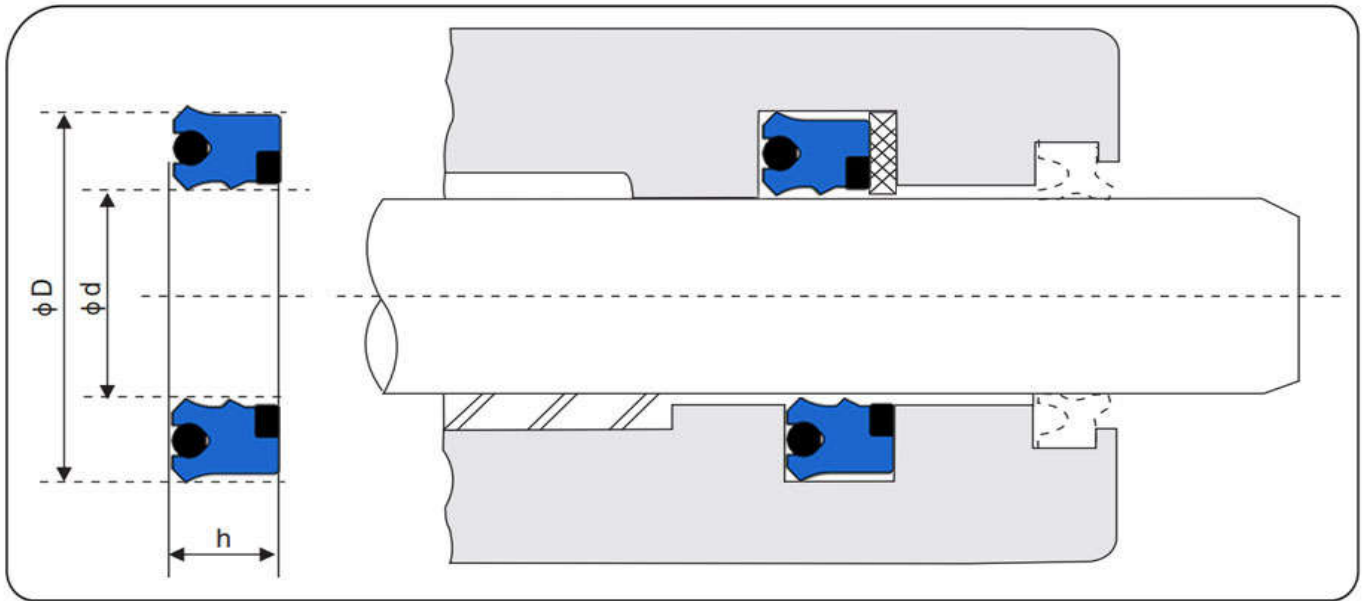

编号 Part No.	ID A	OD B	H C
IRD-40-55-11.4	40	55	11.4
IRD-50-65-11.4	50	65	11.4
IRD-55-70-11.4	55	70	11.4
IRD-60-75-11.4	60	75	11.4
IRD-65-80-11.4	65	80	11.4
IRD-70-85-11.4	70	85	11.4
IRD-75-90-11.4	75	90	11.4
IRD-80-95-11.4	80	95	11.4
IRD-85-100-11.4	85	100	11.4
IRD-90-105-11.4	90	105	11.4
IRD-100-120-14.5	100	120	14.5
IRD-110-130-14.5	110	130	14.5
IRD-120-140-14.5	120	140	14.5
IRD-125-145-14.5	125	145	14.5
IRD-130-150-14.5	130	150	14.5
IRD-140-160-14.5	140	160	14.5
IRD-150-170-14.5	150	170	14.5
IRD-160-180-14.5	160	180	14.5
IRD-170-190-14.5	170	190	14.5

编号 Part No.	ID A	OD B	H C

# MGM

## 活塞杆密封 ROD SEAL



**Material**  
**材质**  
PU+POM  
聚氨酯+聚甲醛

编号 Part No.	ID A	OD B	H C
MGM-30-43-20	30	43	20
MGM-40-55-22.5	40	55	22.5
MGM-50-65-22.5	50	65	22.5
MGM-60-75-22.5	60	75	22.5
MGM-95-110-22.5	95	110	22.5

编号 Part No.	ID A	OD B	H C

## 活塞杆密封

## ROD SEAL

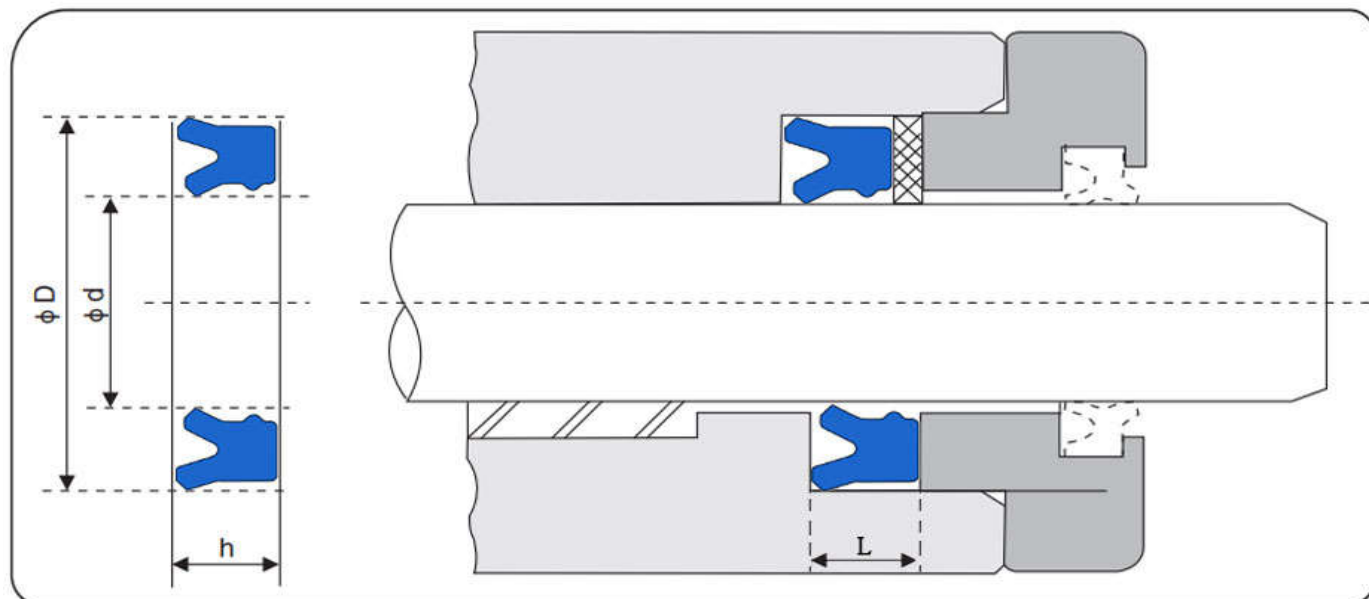

编号 Part No.	内径 $\phi d$	外径 $\phi D$	高度 h	槽宽 L
605 6*15*7.3	6	15	7.3	8
605 6*16*7	6	16	7	8
605 8*18*7	8	18	7	8
605 10*15*3.6	10	15	3.6	4
605 12*18*4	12	18	4	4.5
605 12*18*5.7	12	18	5.7	6.3
605 12*19*4.5	12	19	4.5	5
605 12*19*5	12	19	5	5.6
605 12*20*5.7	12	20	5.7	6.3
605 12*22*7.7	12	22	7.7	9
605 12.7*18*5.5	12.7	18	5.5	6
605 13*20*4.5	13	20	4.5	5
605 14*21*5	14	21	5	5.6
605 14*22*5.7	14	22	5.7	6.3
605 14*24*7.3	14	24	7.3	8
605 15*22*5.7	15	22	5.7	6.3
605 15.4*25.5*6.4	15.4	25.5	6.4	7.4
605 16*22*4.5	16	22	4.5	5
605 16*22*5	16	22	5	6
605 16*24*5.8	16	24	5.8	6.3
605 16*26*7.7	16	26	7.7	9
605 18*24*4.5	18	24	4.5	5
605 18*25*5	18	25	5	6
605 18*26*5	18	26	5	5.7
605 18*26*5.7	18	26	5.7	6.3
605 18*26*6	18	26	6	7
605 18*28*7.7	18	28	7.7	9
605 20*25*3.2	20	25	3.2	3.5
605 20*26*5	20	26	5	5.5
605 20*26*6.5	20	26	6.5	7.6

编号 Part No.	内径 $\phi d$	外径 $\phi D$	高度 h	槽宽 L
605 20*27*6	20	27	6	6.7
605 20*28*5	20	28	5	5.7
605 20*28*5.7	20	28	5.7	6.3
605 20*30*6	20	30	6	7
605 20*30*7.7	20	30	7.7	9
605 20*30*10	20	30	10	11
605 22*30*5	22	30	5	5.7
605 22*30*5.7	22	30	5.7	6.3
605 22*30*7.3	22	30	7.3	8
605 22*32*7.3	22	32	7.3	8
605 22*32*10	22	32	10	11
605 22.4*30*5	22.4	30	5	5.7
605 22.4*32.4*8	22.4	32.4	8	9
605 24*30*4.5	24	30	4.5	5
605 25*33*5	25	33	5	5.7
605 25*33*5.7	25	33	5.7	6.3
605 25*33*6.8	25	33	6.8	7.5
605 25*33*8	25	33	8	9
605 25*33*10	25	33	10	11
605 25*35*7.3	25	35	7.3	8
605 25*35*7.7	25	35	7.7	9
605 25*35*10	25	35	10	11
605 25*37*10	25	37	10	11
605 25*40*10	25	40	10	11
605 26*36*7	26	36	7	8
605 28*35.5*5	28	35.5	5	5.7
605 28*36*5.7	28	36	5.7	6.3
605 28*38*7.3	28	38	7.3	8
605 28*43*11.4	28	43	11.4	12.5
605 30*38*5.7	30	38	5.7	6.3

## 活塞杆密封

## ROD SEAL

编号 Part No	内径 ød	外径 øD	高度 h	槽宽 l
605 30*40*8.5	30	40	8.5	9.5
605 30*40*10	30	40	10	11
605 30*42*10.9	30	42	10.9	12
605 30*45*9	30	45	9	10
605 30*50*10	30	50	10	11
605 32*40*6	32	40	6	7
605 32*40*6.7	32	40	6.7	7.7
605 32*40*7.7	32	40	7.7	9
605 32*41.5*7.9	32	41.5	7.9	8.9
605 32*42*5.7	32	42	5.7	6.3
605 32*42*6	32	42	6	7
605 32*42*7.3	32	42	7.3	8
605 32*42*10	32	42	10	11
605 32*45*10	32	45	10	11
605 32*47*9.1	32	47	9.1	10
605 32*47*10	32	47	10	11
605 32*48*10	32	48	10	11
605 35*43*5.7	35	43	5.7	6.3
605 35*43*6.3	35	43	6.3	7
605 35*43*8.2	35	43	8.2	9
605 35*45*6	35	45	6	7
605 35*45*7	35	45	7	8
605 35*45*7.7	35	45	7.7	9
605 35*45*10	35	45	10	11
605 35*50*9	35	50	9	10
605 35*50*10	35	50	10	11
605 35.5*45*6	35.5	45	6	7
605 35.5*50.5*10	35.5	50.5	10	11
605 36*44*6.4	36	44	6.4	7.5
605 36*44*8.2	36	44	8.2	9
605 36*46*5.7	36	46	5.7	6.3
605 36*46*7.3	36	46	7.3	8
605 36*46*10	36	46	10	11
605 36*51*10	36	51	10	11
605 38*48*8	38	48	8	9
605 38*48*10	38	48	10	11
605 38*50*10	38	50	10	11
605 38*53*10	38	53	10	11
605 40*48*5.7	40	48	5.7	6.3
605 40*48*8.2	40	48	8.2	9
605 40*49.5*9.5	40	49.5	9.5	10.5
605 40*50*6	40	50	6	7
605 40*50*7.3	40	50	7.3	8
605 40*50*10	40	50	10	11
605 40*52*10.9	40	52	10.9	12
605 40*55*7.3	40	55	7.3	8
605 40*55*9	40	55	9	10
605 40*55*10	40	55	10	11
605 42*50*5.7	42	50	5.7	6.3

编号 Part No	内径 ød	外径 øD	高度 h	槽宽 l
605 42*50*7.5	42	50	7.5	8
605 42*52*6	42	52	6	7
605 42*52*10	42	52	10	11
605 45*53*8.1	45	53	8.1	9
605 45*53*11.8	45	53	11.8	13
605 45*55*5.6	45	55	5.6	6.3
605 45*55*6	45	55	6	7
605 45*55*7.3	45	55	7.3	8
605 45*55*10	45	55	10	11
605 45*57.7*9.5	45	57.7	9.5	10.5
605 45*60*10	45	60	10	11
605 45*65*10	45	65	10	11
605 47*56.3*9	47	56.3	9	10
605 48*60*10	48	60	10	11
605 50*57*9	50	57	9	10
605 50*60*6	50	60	6	7
605 50*60*7.3	50	60	7.3	8
605 50*60*10	50	60	10	11
605 50*60*11.8	50	60	11.8	13
605 50*62.7*9.5	50	62.7	9.5	10.5
605 50*63*10	50	63	10	11
605 50*65*9	50	65	9	10
605 50*65*9.5	50	65	9.5	10.5
605 50*65*10	50	65	10	11
605 50*65*10.9	50	65	10.9	12
605 50*65*14.5	50	65	14.5	16
605 50*70*12	50	70	12	13
605 53*63*6	53	63	6	7
605 53*65*9	53	65	9	10
605 55*65*6	55	65	6	7
605 55*65*7.3	55	65	7.3	8
605 55*65*8.2	55	65	8.2	9
605 55*65*10	55	65	10	11
605 55*65*11.8	55	65	11.8	13
605 55*68*10	55	68	10	11
605 55*70*9	55	70	9	10
605 55*70*11.8	55	70	11.8	13
605 55*75*12	55	75	12	13
605 56*66*10	56	66	10	11
605 56*71*10	56	71	10	11
605 56*71*11.4	56	71	11.4	12.5
605 60*68*11.4	60	68	11.4	12.5
605 60*70*6	60	70	6	7
605 60*70*7.3	60	70	7.3	8
605 60*70*10	60	70	10	11
605 60*70*11.8	60	70	11.8	13
605 60*71*7	60	71	7	8
605 60*72*10	60	72	10	11
605 60*73*10	60	73	10	11

## 活塞杆密封

## ROD SEAL

编号 Part No	内径 ød	外径 øD	高度 h	槽宽 l
605 60*75*9	60	75	9	10
605 60*75*10	60	75	10	11
605 60*75*11.8	60	75	11.8	13
605 60*75*20.5	60	75	20.5	22.5
605 60*80*11.4	60	80	11.4	12.5
605 60*80*12	60	80	12	13
605 63*73*6	63	73	6	7
605 63*73*11.8	63	73	11.8	13
605 63*78*10	63	78	10	11
605 63*78*11.4	63	78	11.4	12.5
605 65*75*6	65	75	6	7
605 65*75*7.7	65	75	7.7	9
605 65*75*11.8	65	75	11.8	13
605 65*77*9	65	77	9	10
605 65*77.7*9.5	65	77.7	9.5	10.5
605 65*78*10	65	78	10	11
605 65*80*9	65	80	9	10
605 65*80*11.8	65	80	11.8	13
605 65*85*12	65	85	12	13
605 67*77*6	67	77	6	7
605 70*80*6	70	80	6	7
605 70*80*11.8	70	80	11.8	13
605 70*82*8.7	70	82	8.7	9.6
605 70*82*10	70	82	10	11
605 70*83*10	70	83	10	11
605 70*85*9	70	85	9	10
605 70*85*10	70	85	10	11
605 70*85*11.4	70	85	11.4	12.5
605 70*85*20.5	70	85	20.5	22.5
605 70*90*12	70	90	12	13
605 75*83*11.4	75	83	11.4	12.5
605 75*85*6	75	85	6	7
605 75*85*11.8	75	85	11.8	13
605 75*88*10	75	88	10	11
605 75*90*9	75	90	9	10
605 75*95*12	75	95	12	13
605 78*86*9	78	86	9	10
605 80*100*12	80	100	12	13
605 80*100*14.5	80	100	14.5	16
605 80*110*16.4	80	110	16.4	18
605 80*88*10.9	80	88	10.9	12
605 80*90*6	80	90	6	7
605 80*90*10	80	90	10	11
605 80*90*11.8	80	90	11.8	13
605 80*92*8.7	80	92	8.7	9.6
605 80*93*10	80	93	10	11
605 80*95*9	80	95	9	10
605 80*95*10	80	95	10	11
605 80*95*11.8	80	95	11.8	13

编号 Part No	内径 ød	外径 øD	高度 h	槽宽 l
605 85*100*9	85	100	9	10
605 85*100*10	85	100	10	11
605 85*100*11.8	85	100	11.8	13
605 85*105*12	85	105	12	13
605 85*93*10	85	93	10	11
605 85*93*11.4	85	93	11.4	12.5
605 90*100*6.8	90	100	6.8	7.5
605 90*100*9	90	100	9	10
605 90*100*11.8	90	100	11.8	13
605 90*102*8.7	90	102	8.7	9.6
605 90*105*9	90	105	9	10
605 90*105*10	90	105	10	11
605 90*105*11.4	90	105	11.4	12.5
605 90*110*12	90	110	12	13
605 90*98*11.4	90	98	11.4	12.5
605 95*110*9	95	110	9	10
605 95*110*10	95	110	10	11
605 95*110*11.8	95	110	11.8	13
605 95*115*12	95	115	12	13
605 96*104*10.9	96	104	10.9	12
605 98*112*8.5	98	112	8.5	9.5
605 100*108*10.9	100	108	10.9	12
605 100*110*10.9	100	110	10.9	12
605 100*115*9	100	115	9	10
605 100*115*10	100	115	10	11
605 100*115*11.8	100	115	11.8	13
605 100*120*11.8	100	120	11.8	13
605 100*120*14.5	100	120	14.5	16
605 105*113*10	105	113	10	11
605 105*115*13.2	105	115	13.2	14.5
605 105*120*9	105	120	9	10
605 105*120*10	105	120	10	11
605 105*120*14.5	105	120	14.5	16
605 105*125*14.5	105	125	14.5	16
605 108*123*10.9	108	123	10.9	12
605 110*125*9	110	125	9	10
605 110*125*11	110	125	11	12
605 110*125*14.5	110	125	14.5	16
605 110*130*11.8	110	130	11.8	13
605 110*130*14.5	110	130	14.5	16
605 110*135*14.5	110	135	14.5	16
605 112*125*9	112	125	9	10
605 115*125*0	115	125	0	12
605 115*130*9	115	130	9	10
605 115*130*10.9	115	130	10.9	12
605 115*130*14.5	115	130	14.5	16
605 120*128*11.4	120	128	11.4	12.5
605 120*130*10.9	120	130	10.9	12
605 120*135*9	120	135	9	10



# RST(HBTS K35 OMS-MR OD RSK)

## 缓冲密封

## ROD BUFFER SEAL



Material  
材质

PTFE+NBR  
四氟+丁腈橡胶

编号 Part No.	ID A	OD B	H C	GH D
RST-3-2.2	3	7.9	2	2.2
RST-4-2.2	4	8.9	2	2.2
RST-5-2.2	5	9.9	2	2.2
RST-6-2.2	6	10.9	2	2.2
RST-8-2.2	8	12.9	2	2.2
RST-9-2.2	9	13.9	2	2.2
RST-10-2.2	10	14.9	2	2.2
RST-12-2.2	12	16.9	2	2.2
RST-14-2.2	14	18.9	2	2.2
RST-15-2.2	15	19.9	2	2.2
RST-16-2.2	16	20.9	2	2.2
RST-17-2.2	17	21.9	2	2.2
RST-18-2.2	18	23	2	2.2
RST-8-3.2	8	15.3	3	3.2
RST-9-3.2	9	16.3	3	3.2
RST-16-3.2	16	23.3	3	3.2
RST-18-3.2	18	25.3	3	3.2
RST-25-3.2	25	32.3	3	3.2
RST-32-3.2	32	39.3	3	3.2
RST-35-3.2	35	42.3	3	3.2
RST-19-4.2	19	29.7	3.9	4.2
RST-20-4.2	20	30.7	3.9	4.2
RST-25-4.2	25	35.7	3.9	4.2
RST-26-4.2	26	36.7	3.9	4.2
RST-28-4.2	28	38.7	3.9	4.2
RST-30-4.2	30	40.7	3.9	4.2
RST-32-4.2	32	42.7	3.9	4.2
RST-35-4.2	35	45.7	3.9	4.2
RST-36-4.2	36	46.7	3.9	4.2
RST-37-4.2	37	47.7	3.9	4.2
RST-38-4.2	38	48.7	3.9	4.2
RST-40-4.2	40	50.7	3.9	4.2

编号 Part No.	ID A	OD B	H C	GH D
RST-43-4.2	43	53.7	3.9	4.2
RST-45-4.2	45	55.7	3.9	4.2
RST-48-4.2	48	58.7	3.9	4.2
RST-50-4.2	50	60.7	3.9	4.2
RST-52-4.2	52	62.7	3.9	4.2
RST-55-4.2	55	65.7	3.9	4.2
RST-60-4.2	60	70.7	3.9	4.2
RST-63-4.2	63	73.7	3.9	4.2
RST-65-4.2	65	75.7	3.9	4.2
RST-68-4.2	68	78.7	3.9	4.2
RST-70-4.2	70	80.7	3.9	4.2
RST-75-4.2	75	85.7	3.9	4.2
RST-85-4.2	85	95.7	3.9	4.2
RST-90-4.2	90	100.7	3.9	4.2
RST-95-4.2	95	105.7	3.9	4.2
RST-100-4.2	100	110.7	3.9	4.2
RST-110-4.2	110	120.7	3.9	4.2
RST-135-4.2	135	145.7	3.9	4.2
RST-140-4.2	140	150.7	3.9	4.2
RST-35-6.3	35	50.1	5.9	6.3
RST-40-6.3	40	55.1	5.9	6.3
RST-45-6.3	45	60.1	5.9	6.3
RST-48-6.3	48	63.1	5.9	6.3
RST-50-6.3	50	65.1	5.9	6.3
RST-55-6.3	55	70.1	5.9	6.3
RST-56-6.3	56	71.1	5.9	6.3
RST-57-6.3	57	72.1	5.9	6.3
RST-60-6.3	60	75.1	5.9	6.3
RST-65-6.3	65	80.1	5.9	6.3
RST-67-6.3	67	82.1	5.9	6.3
RST-70-6.3	70	85.1	5.9	6.3
RST-75-6.3	75	90.1	5.9	6.3



# RST(HBTS K35 OMS-MR OD RSK)

## 缓冲密封

### ROD BUFFER SEAL

编号 Part No	ID A	OD B	H C	GH D
RST-78-6.3	78	93.1	5.9	6.3
RST-80-6.3	80	95.1	5.9	6.3
RST-85-6.3	85	100.1	5.9	6.3
RST-90-6.3	90	105.1	5.9	6.3
RST-92-6.3	92	107.1	5.9	6.3
RST-95-6.3	95	110.1	5.9	6.3
RST-98-6.3	98	113.1	5.9	6.3
RST-100-6.3	100	115.1	5.9	6.3
RST-105-6.3	105	120.1	5.9	6.3
RST-110-6.3	110	125.1	5.9	6.3
RST-115-6.3	115	130.1	5.9	6.3
RST-117-6.3	117	132.1	5.9	6.3
RST-120-6.3	120	135.1	5.9	6.3
RST-125-6.3	125	140.1	5.9	6.3
RST-127-6.3	127	142.1	5.9	6.3
RST-130-6.3	130	145.1	5.9	6.3
RST-132-6.3	132	147.1	5.9	6.3
RST-135-6.3	135	150.1	5.9	6.3
RST-137-6.3	137	152.1	5.9	6.3
RST-138-6.3	138	153.1	5.9	6.3
RST-140-6.3	140	155.1	5.9	6.3
RST-145-6.3	145	160.1	5.9	6.3
RST-150-6.3	150	165.1	5.9	6.3
RST-153-6.3	153	168.1	5.9	6.3
RST-155-6.3	155	170.1	5.9	6.3
RST-160-6.3	160	175.1	5.9	6.3
RST-165-6.3	165	180.1	5.9	6.3
RST-170-6.3	170	185.1	5.9	6.3
RST-175-6.3	175	190.1	5.9	6.3
RST-180-6.3	180	195.1	5.9	6.3
RST-185-6.3	185	200.1	5.9	6.3
RST-190-6.3	190	205.1	5.9	6.3
RST-192-6.3	192	207.1	5.9	6.3
RST-195-6.3	195	210.1	5.9	6.3
RST-200-6.3	200	215.1	5.9	6.3
RST-210-6.3	210	225.1	5.9	6.3
RST-220-6.3	220	235.1	5.9	6.3
RST-230-6.3	230	245.1	5.9	6.3
RST-70-8.1	70	90.5	7.9	8.1
RST-80-8.1	80	100.5	7.9	8.1
RST-100-8.1	100	120.5	7.9	8.1
RST-105-8.1	105	125.5	7.9	8.1
RST-110-8.1	110	130.5	7.9	8.1
RST-115-8.1	115	135.5	7.9	8.1
RST-120-8.1	120	140.5	7.9	8.1
RST-125-8.1	125	145.5	7.9	8.1
RST-130-8.1	130	150.5	7.9	8.1
RST-135-8.1	135	155.5	7.9	8.1
RST-140-8.1	140	160.5	7.9	8.1
RST-150-8.1	150	170.5	7.9	8.1
RST-160-8.1	160	180.5	7.9	8.1
RST-170-8.1	170	190.5	7.9	8.1
RST-172-8.1	172	192.5	7.9	8.1
RST-180-8.1	180	200.5	7.9	8.1

编号 Part No	ID A	OD B	H C	GH D
RST-185-8.1	185	205.5	7.9	8.1
RST-190-8.1	190	210.5	7.9	8.1
RST-195-8.1	195	215.5	7.9	8.1
RST-200-8.1	200	220.5	7.9	8.1
RST-205-8.1	205	225.5	7.9	8.1
RST-210-8.1	210	230.5	7.9	8.1
RST-212-8.1	212	232.5	7.9	8.1
RST-215-8.1	215	235.5	7.9	8.1
RST-220-8.1	220	240.5	7.9	8.1
RST-230-8.1	230	250.5	7.9	8.1
RST-240-8.1	240	260.5	7.9	8.1
RST-250-8.1	250	270.5	7.9	8.1
RST-255-8.1	255	275.5	7.9	8.1
RST-260-8.1	260	280.5	7.9	8.1
RST-270-8.1	270	290.5	7.9	8.1
RST-280-8.1	280	300.5	7.9	8.1
RST-285-8.1	285	305.5	7.9	8.1
RST-290-8.1	290	310.5	7.9	8.1
RST-295-8.1	295	315.5	7.9	8.1
RST-300-8.1	300	320.5	7.9	8.1
RST-310-8.1	310	330.5	7.9	8.1
RST-320-8.1	320	340.5	7.9	8.1
RST-330-8.1	330	350.5	7.9	8.1
RST-340-8.1	340	360.5	7.9	8.1
RST-345-8.1	345	365.5	7.9	8.1
RST-350-8.1	350	370.5	7.9	8.1
RST-360-8.1	360	384	7.9	8.1
RST-365-8.1	365	389	7.9	8.1
RST-370-8.1	370	394	7.9	8.1
RST-375-8.1	375	399	7.9	8.1
RST-380-8.1	380	404	7.9	8.1
RST-390-8.1	390	414	7.9	8.1
RST-400-8.1	400	424	7.9	8.1
RST-405-8.1	405	429	7.9	8.1
RST-410-8.1	410	434	7.9	8.1
RST-420-8.1	420	444	7.9	8.1
RST-430-8.1	430	454	7.9	8.1
RST-435-8.1	435	459	7.9	8.1
RST-440-8.1	440	464	7.9	8.1
RST-450-8.1	450	474	7.9	8.1
RST-460-8.1	460	484	7.9	8.1
RST-470-8.1	470	494	7.9	8.1
RST-480-8.1	480	504	7.9	8.1
RST-485-8.1	485	509	7.9	8.1
RST-490-8.1	490	514	7.9	8.1
RST-500-8.1	500	524	7.9	8.1
RST-510-8.1	510	534	7.9	8.1
RST-520-8.1	520	544	7.9	8.1
RST-530-8.1	530	554	7.9	8.1
RST-540-8.1	540	564	7.9	8.1
RST-550-8.1	550	574	7.9	8.1
RST-560-8.1	560	584	7.9	8.1
RST-570-8.1	570	594	7.9	8.1
RST-600-8.1	600	624	7.9	8.1

# HBS (HBY)

## 缓冲密封 ROD BUFFER SEAL



Material  
材质  
PU+NY  
聚氨酯+尼龙

编号 Part No.	ID A	OD B	H C	GH D
HBS-40-6.3	40	55.5	6	6.3
HBS-45-6.3	45	60.5	6	6.3
HBS-50-6.3	50	65.5	6	6.3
HBS-55-6.3	55	70.5	6	6.3
HBS-60-6.3	60	75.5	6	6.3
HBS-65-6.3	65	80.5	6	6.3
HBS-70-6.3	70	85.5	6	6.3
HBS-75-6.3	75	90.5	6	6.3
HBS-80-6.3	80	95.5	6	6.3
HBS-85-6.3	85	100.5	6	6.3
HBS-90-6.3	90	105.5	6	6.3
HBS-95-6.3	95	110.5	6	6.3
HBS-100-6.3	100	115.5	6	6.3
HBS-105-6.3	105	120.5	6	6.3
HBS-110-6.3	110	125.5	6	6.3
HBS-115-6.3	115	130.5	6	6.3
HBS-120-6.3	120	135.5	6	6.3
HBS-125-6.3	125	140.5	6	6.3
HBS-130-6.3	130	145.5	6	6.3
HBS-135-6.3	135	150.5	6	6.3
HBS-140-6.3	140	155.5	6	6.3
HBS-145-6.3	145	160.5	6	6.3
HBS-150-6.3	150	165.5	6	6.3
HBS-155-6.3	155	170.5	6	6.3
HBS-160-6.3	160	175.5	6	6.3
HBS-170-6.3	170	185.5	6	6.3
HBS-175-6.3	175	190.5	6	6.3
HBS-180-6.3	180	195.5	6	6.3
HBS-185-6.3	185	200.5	6	6.3
HBS-190-6.3	190	205.5	6	6.3

编号 Part No.	ID A	OD B	H C	GH D
HBS-40-3.2	40	45.5		3.2
HBS-45-3.2	45	50.5		3.2
HBS-60-3.8	60	66.5		3.8
HBS-40-3.9	40	50.7		3.9
HBS-45-3.9	45	55.7		3.9
HBS-45-4.2	45	53		4.2
HBS-60-4.2	60	68		4.2
HBS-70-4.2	70	78		4.2
HBS-80-4.2	80	88		4.2
HBS-90-4.2	90	98		4.2
HBS-95-5.2	95	105		5.2
HBS-100-5.2	100	110		5.2
HBS-105-5.2	105	115		5.2
HBS-110-5.2	110	120		5.2
HBS-115-5.2	115	125		5.2
HBS-120-5.2	120	130		5.2
HBS-125-5.2	125	135		5.2
HBS-130-5.2	130	140		5.2
HBS-132-5.2	132	142		5.2
HBS-150-5.2	150	160		5.2
HBS-160-5.2	160	172		5.2
HBS-170-6.2	170	182		6.2
HBS-180-6.2	180	192		6.2
HBS-185-6.2	185	197		6.2
HBS-210-6.2	210	222		6.2
HBS-250-6.2	250	262		6.2
HBS-210-7.7	210	231		7.7

# HBB

## 缓冲密封 ROD BUFFER SEAL

Material  
材质  
PU  
聚氨酯

编号 Part No.	ID A	OD B	H C	GH D
HBB-40-6.3	40	55.5	6	6.3
HBB-45-6.3	45	60.5	6	6.3
HBB-50-6.3	50	65.5	6	6.3
HBB-55-6.3	55	70.5	6	6.3
HBB-60-6.3	60	75.5	6	6.3
HBB-65-6.3	65	80.5	6	6.3
HBB-70-6.3	70	85.5	6	6.3
HBB-75-6.3	75	90.5	6	6.3
HBB-80-6.3	80	95.5	6	6.3
HBB-85-6.3	85	100.5	6	6.3
HBB-90-6.3	90	105.5	6	6.3
HBB-95-6.3	95	110.5	6	6.3
HBB-100-6.3	100	115.5	6	6.3
HBB-105-6.3	105	120.5	6	6.3
HBB-110-6.3	110	125.5	6	6.3
HBB-115-6.3	115	130.5	6	6.3
HBB-120-6.3	120	135.5	6	6.3
HBB-125-6.3	125	140.5	6	6.3
HBB-130-6.3	130	145.5	6	6.3
HBB-135-6.3	135	150.5	6	6.3
HBB-140-6.3	140	155.5	6	6.3
HBB-145-6.3	145	160.5	6	6.3
HBB-150-6.3	150	165.5	6	6.3
HBB-155-6.3	155	170.5	6	6.3
HBB-160-6.3	160	175.5	6	6.3
HBB-170-6.3	170	185.5	6	6.3
HBB-175-6.3	175	190.5	6	6.3
HBB-180-6.3	180	195.5	6	6.3
HBB-185-6.3	185	200.5	6	6.3
HBB-186-6.3	186	201.5	6	6.3

编号 Part No.	ID A	OD B	H C	GH D
HBB-190-6.3	190	205.5	6	6.3
HBB-108-6.3	108	123.5	6	6.3
HBB-124-6.3	124	139.5	6	6.3

## 缓冲密封 ROD BUFFER SEAL

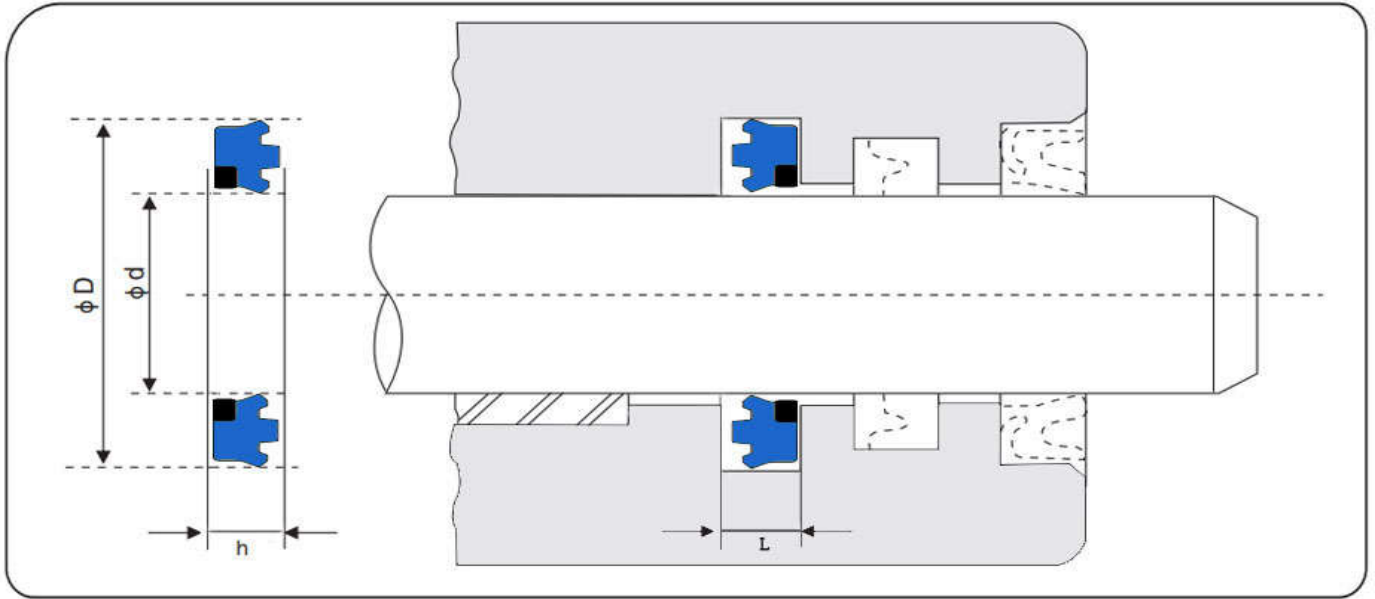

编号 Part No.	ID A	OD B	H C	GH D
HBU-60-6.1	60	75	6.1	6.3
HBU-65-6.1	65	80.5	6.1	6.3
HBU-70-6.1	70	85.5	6.1	6.3
HBU-75-6.1	75	90.5	6.1	6.3
HBU-80-6.1	80	95.1	6.1	6.3
HBU-80-6.1	80	95.5	6.1	6.3
HBU-85-6.1	85	100.5	6.1	6.3
HBU-90-6.1	90	105.5	6.1	6.3
HBU-95-6.1	95	110.5	6.1	6.3
HBU-100-6.1	100	115.5	6.1	6.3
HBU-110-6.1	110	125.5	6.1	6.3
HBU-55-8.5	55	70	8.5	9.5
HBU-56-8.5	56	71	8.5	9.5
HBU-60-8.5	60	75	8.5	9.5
HBU-70-8.5	70	85	8.5	9.5
HBU-75-8.5	75	90	8.5	9.5
HBU-80-8.5	80	95	8.5	9.5
HBU-90-8.5	90	105	8.5	9.5
HBU-100-11.4	100	120	11.4	12.5
HBU-110-11.4	110	130	11.4	12.5
HBU-120-11.4	120	140	11.4	12.5
HBU-130-14.5	130	150	14.5	16
HBU-140-14.5	140	160	14.5	16
HBU-150-14.5	150	170	14.5	16
HBU-160-14.5	160	180	14.5	16

编号 Part No.	ID A	OD B	H C	GH D

# DKS (DKB)

防尘密封  
DUST WIPER SEAL



Material  
材质

NBR+IRON  
丁腈橡胶+铁

编号 Part No.	ID A	OD B	h C	H C1
DKS-14	14	24	5	7
DKS-19	19	31	6	9
DKS-20	20	32	6	9
DKS-25	25	37	6	9
DKS-28	28	40	6	9
DKS-30	30	42	6	9
DKS-32	32	44	6	9
DKS-35	35	47	7	10
DKS-40	40	52	7	10
DKS-45	45	57	7	10
DKS-50	50	62	7	10
DKS-55	55	69	8	11
DKS-60	60	74	8	11
DKS-65	65	79	8	11
DKS-70	70	84	8	11
DKS-75	75	89	8	11
DKS-80	80	94	8	11
DKS-85	85	99	8	11
DKS-90	90	104	8	11
DKS-95	95	109	8	11
DKS-100	100	114	8	11
DKS-105	105	121	9	12
DKS-110	110	126	9	12
DKS-115	115	131	9	12
DKS-120	120	136	9	12
DKS-125	125	141	9	12
DKS-130	130	146	9	12
DKS-135	135	155	10	14
DKS-140	140	160	10	14
DKS-145	145	165	10	14

编号 Part No.	ID A	OD B	h C	H C1
DKS-150	150	170	10	14
DKS-160	160	180	10	14
DKS-170	170	190	10	14
DKS-175	175	195	10	14
DKS-180	180	205	12	17
DKS-185	185	210	12	17
DKS-190	190	215	12	17
DKS-200	200	225	12	17
DKS-210	210	235	12	17
DKS-220	220	245	12	17
DKS-250	250	275	12	17

# DKP (DKBI)

## 防尘密封 DUST WIPER SEAL

Material  
材质

PU+IRON  
聚氨酯+铁

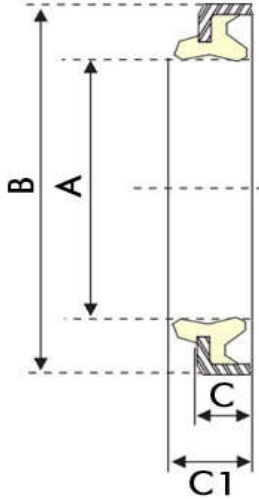

编号 Part No.	ID A	OD B	h C	H C1
DKP-14	14	24	5	7
DKP-16	16	26	5	7
DKP-18	18	30	6	9
DKP-19	19	31	6	9
DKP-20	20	32	6	9
DKP-22	22	34	6	9
DKP-25	25	37	6	9
DKP-30	30	42	6	9
DKP-32	32	52	8	11
DKP-35	35	47	7	10
DKP-40	40	52	7	10
DKP-45	45	57	7	10
DKP-50	50	62	7	10
DKP-55	55	69	8	11
DKP-60	60	74	8	11
DKP-65	65	79	8	11
DKP-70	70	84	8	11
DKP-75	75	89	8	11
DKP-80	80	94	8	11
DKP-85	85	99	8	11
DKP-90	90	104	8	11
DKP-95	95	109	8	11
DKP-100	100	114	8	11
DKP-105	105	121	9	12
DKP-110	110	126	9	12
DKP-115	115	131	9	12
DKP-120	120	136	9	12
DKP-125	125	141	9	12
DKP-130	130	146	9	12
DKP-135	135	155	10	14

编号 Part No.	ID A	OD B	h C	H C1
DKP-140	140	160	10	14
DKP-145	145	165	10	14
DKP-150	150	170	10	14
DKP-160	160	180	10	14
DKP-180	180	205	12	17
DKP-200	200	225	12	17

# DGA (GA GPA)

## 防尘密封 DUST WIPER SEAL



Material  
材质

NBR+IRON  
丁腈橡胶+铁

编号 Part No.	ID A	OD B	h C	H C1
DGA-15-25-7/10	15	25	7	10
DGA-18-26-7/10	18	26	7	10
DGA-18-28-7/10	18	28	7	10
DGA-20-30-7/10	20	30	7	10
DGA-22-32-7/10	22	32	7	10
DGA-22-35-7/10	22	35	7	10
DGA-25-35-7/10	25	35	7	10
DGA-28-38-7/10	28	38	7	10
DGA-30-40-7/10	30	40	7	10
DGA-32-42-7/10	32	42	7	10
DGA-32-45-7/10	32	45	7	10
DGA-35-45-7/10	35	45	7	10
DGA-36-45-7/10	36	45	7	10
DGA-36-46-7/10	36	46	7	10
DGA-38-48-7/10	38	48	7	10
DGA-40-50-7/10	40	50	7	10
DGA-45-55-7/10	45	55	7	10
DGA-45-60-7/10	45	60	7	10
DGA-50-60-7/10	50	60	7	10
DGA-50-65-7/10	50	65	7	10
DGA-55-65-7/10	55	65	7	10
DGA-55-70-7/10	55	70	7	10
DGA-56-66-7/10	56	66	7	10
DGA-60-70-7/10	60	70	7	10
DGA-63-73-7/10	63	73	7	10
DGA-63-75-7/10	63	75	7	10
DGA-63-78-7/10	63	78	7	10
DGA-65-75-7/10	65	75	7	10
DGA-70-80-7/10	70	80	7	10
DGA-75-83-7/10	75	83	7	10

编号 Part No.	ID A	OD B	h C	H C1
DGA-75-85-7/10	75	85	7	10
DGA-80-90-7/10	80	90	7	10
DGA-85-95-7/10	85	95	7	10
DGA-90-100-7/10	90	100	7	10
DGA-100-110-7/10	100	110	7	10
DGA-105-115-7/10	105	115	7	10
DGA-110-120-7/10	110	120	7	10
DGA-115-125-7/10	115	125	7	10
DGA-120-130-7/10	120	130	7	10
DGA-125-140-9/12	125	140	7	10
DGA-140-155-9/12	140	155	9	12
DGA-160-175-9/12	160	175	9	12
DGA-180-195-9/12	180	195	9	12

# DSYK(LBI DH DHS) NOK(JP) standard

防尘密封

DUST WIPER SEAL

Material  
材质

PU  
聚氨酯

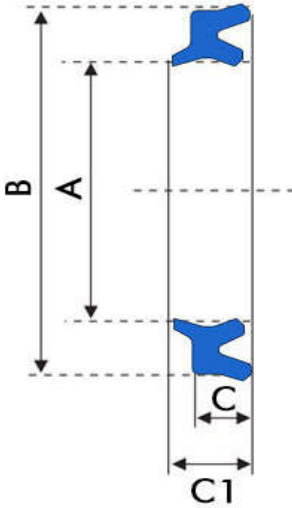

编号 Part No.	ID A	OD B	h C	H C1
DSYK-11.2-19.2-4.5/6	11.2	19.2	4.5	6
DSYK-12.5-20.5-4.5/6	12.5	20.5	4.5	6
DSYK-14-22-4.5/6	14	22	4.5	6
DSYK-16-24-4.5/6	16	24	4.5	6
DSYK-18-26-4.5/6	18	26	4.5	6
DSYK-20-28-4.5/6	20	28	4.5	6
DSYK-22-30-4.5/6	22	30	4.5	6
DSYK-22.4-30.4-4.5/6	22.4	30.4	4.5	6
DSYK-23.5-31.5-4.5/6	23.5	31.5	4.5	6
DSYK-25-33-4.5/6	25	33	4.5	6
DSYK-26-32-4.5/6	26	32	4.5	6
DSYK-28-36-4.5/6	28	36	4.5	6
DSYK-30-38-5/6.5	30	38	5	6.5
DSYK-31.5-39.5-5/6.5	31.5	39.5	5	6.5
DSYK-32-40-5/6.5	32	40	5	6.5
DSYK-35-43-5/6.5	35	43	5	6.5
DSYK-35.5-43.5-5/6.5	35.5	43.5	5	6.5
DSYK-38-46-5/6.5	38	46	5	6.5
DSYK-40-48-5/6.5	40	48	5	6.5
DSYK-45-53-5/6.5	45	53	5	6.5
DSYK-50-58-5/6.5	50	58	5	6.5
DSYK-53-61-5/6.5	53	61	5	6.5
DSYK-55-63-5/6.5	55	63	5	6.5
DSYK-56-64-5/6.5	56	64	5	6.5
DSYK-58-66-5/6.5	58	66	5	6.5
DSYK-60-68-5/6.5	60	68	5	6.5
DSYK-63-71-5/6.5	63	71	5	6.5
DSYK-65-73-5/6.5	65	73	5	6.5
DSYK-67-75-5/6.5	67	75	5	6.5
DSYK-70-80-6/8	70	80	6	8
DSYK-71-81-6/8	71	81	6	8
DSYK-75-85-6/8	75	85	6	8

编号 Part No.	ID A	OD B	h C	H C1
DSYK-80-90-6/8	80	90	6	8
DSYK-85-95-6/8	85	95	6	8
DSYK-90-100-6/8	90	100	6	8
DSYK-95-105-6/8	95	105	6	8
DSYK-98-108-6/8	98	108	6	8
DSYK-100-110-6/8	100	110	6	8
DSYK-105-115-6/8	105	115	6	8
DSYK-106-116-6/8	106	116	6	8
DSYK-110-120-6/8	110	120	6	8
DSYK-112-122-6/8	112	122	6	8
DSYK-115-125-6/8	115	125	6	8
DSYK-120-130-6/8	120	130	6	8
DSYK-125-138-7/9.5	125	138	7	9.5
DSYK-130-143-7/9.5	130	143	7	9.5
DSYK-135-148-7/9.5	135	148	7	9.5
DSYK-136-149-7/9.5	136	149	7	9.5
DSYK-140-153-7/9.5	140	153	7	9.5
DSYK-145-158-7/9.5	145	158	7	9.5
DSYK-150-163-7/9.5	150	163	7	9.5
DSYK-160-174-7/9.5	160	174	7	9.5
DSYK-165-179-7/9.5	165	179	7	9.5
DSYK-170-185-7/9.5	170	185	7	9.5
DSYK-175-188-7/9.5	175	188	7	9.5
DSYK-180-194-7/9.5	180	194	7	9.5
DSYK-190-204-7/9.5	190	204	7	9.5
DSYK-200-214-7/9.5	200	214	7	9.5
DSYK-204-218-7/9.5	204	218	7	9.5
DSYK-210-223-7/9.5	210	223	7	9.5
DSYK-220-233-7/9.5	220	233	7	9.5
DSYK-224-238-7/9.5	224	238	7	9.5
DSYK-230-244-7/9.5	230	244	7	9.5
DSYK-250-263-7/9.5	250	263	7	9.5



# DSYP (AY) Parker (USA) standard

防尘密封

DUST WIPER SEAL

Material  
材质

PU  
聚氨酯

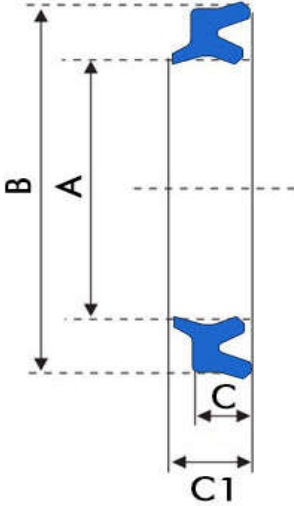

编号 Part No.	ID A	OD B	h C	H C1
DSYP-10	10	16	3.6	4.8
DSYP-12	12	18	3.6	4.8
DSYP-14	14	20	3.6	4.8
DSYP-16	16	22	3.6	4.8
DSYP-18	18	24	3.6	4.8
DSYP-20	20	26	3.6	4.8
DSYP-22	22	28	3.6	4.8
DSYP-25	25	31	3.6	4.8
DSYP-28	28	36	4.5	5.8
DSYP-30	30	38	4.5	5.8
DSYP-32	32	40	4.5	5.8
DSYP-35	35	43	4.5	5.8
DSYP-36	36	44	4.5	5.8
DSYP-40	40	48	4.5	5.8
DSYP-45	45	53	4.5	5.8
DSYP-50	50	58	4.5	5.8
DSYP-55	55	65	5.3	6.8
DSYP-60	60	70	5.3	6.8
DSYP-63	63	73	5.3	6.8
DSYP-65	65	75	5.3	6.8
DSYP-70	70	80	5.3	6.8
DSYP-75	75	85	5.3	6.8
DSYP-80	80	90	5.3	6.8
DSYP-85	85	95	5.3	6.8
DSYP-90	90	100	5.3	6.8
DSYP-100	100	110	5.3	6.8
DSYP-110	110	125	7.5	9.5
DSYP-125	125	140	7.5	9.5
DSYP-140	140	155	7.5	9.5

编号 Part No.	ID A	OD B	h C	H C1

DSYG(GHW K27 WED) Guarnitec(EU) standard

防尘密封

DUST WIPER SEAL

Material  
材质

PU  
聚氨酯

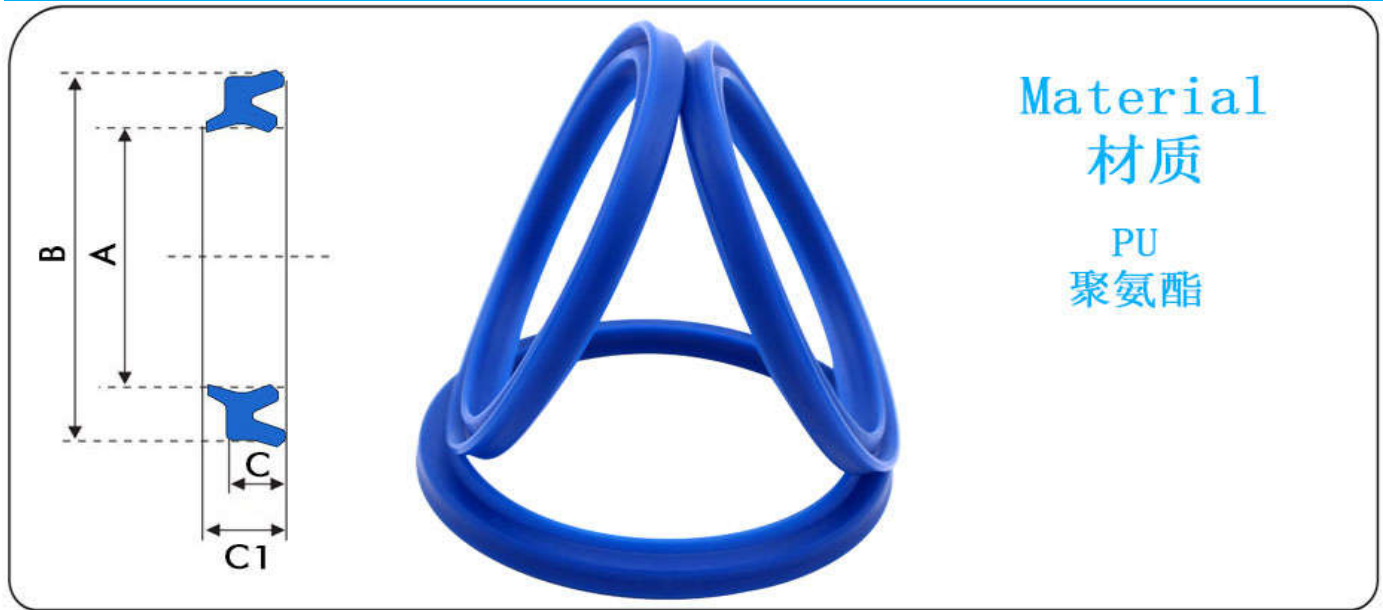

编号 Part No.	ID A	OD B	h C	H C1
DSYG-18	18	26.6	5.3	7
DSYG-20	20	28.6	5.3	7
DSYG-22	22	30.6	5.3	7
DSYG-24	24	32.6	5.3	7
DSYG-25	25	33.6	5.3	7
DSYG-28	28	36.6	5.3	7
DSYG-30	30	38.6	5.3	7
DSYG-32	32	40.6	5.3	7
DSYG-35A	35	42.6	5.3	7
DSYG-35	35	43.6	5.3	7
DSYG-36	36	44.6	5.3	7
DSYG-40	40	48.6	5.3	7
DSYG-42	42	50.6	5.3	7
DSYG-45	45	53.6	5.3	7
DSYG-50	50	58.6	5.3	7
DSYG-55	55	63.6	5.3	7
DSYG-56	56	64.6	5.3	7
DSYG-60	60	68.6	5.3	7
DSYG-60A	60	70.6	5.3	7
DSYG-63	63	71.6	5.3	7
DSYG-63A	63	73.6	5.3	7
DSYG-65	65	73.6	5.3	7
DSYG-70	70	78.6	5.3	7
DSYG-75	75	83.6	5.3	7
DSYG-80	80	88.6	5.3	7
DSYG-80A	80	92.2	7.1	12
DSYG-85	85	97.2	7.1	12
DSYG-90	90	102.2	7.1	12
DSYG-100	100	112.2	7.1	12

编号 Part No.	ID A	OD B	h C	H C1
DSYG-105	105	117.2	7.1	12
DSYG-110	110	122.2	7.1	12
DSYG-115	115	127.2	7.1	12
DSYG-120	120	132.2	7.1	12
DSYG-130	130	142.2	7.1	12
DSYG-132	132	144.2	7.1	12
DSYG-135	135	147.2	7.1	12

DSP(A1 GHP K09 MSWS ASW WWS)

防尘密封  
DUST WIPER SEAL

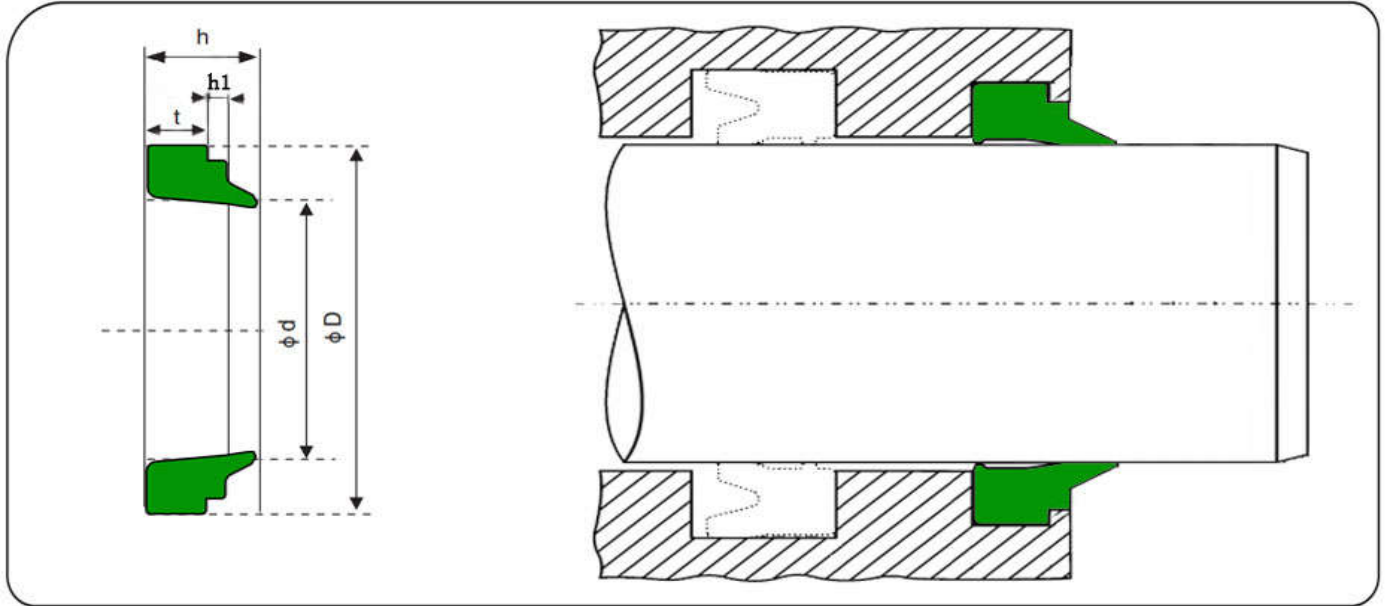

编号 Part No.	ID ød	OD øD	H t	H h	H h1
DSP-20-28-4/7	20	28	4	7	1
DSP-25-33-4/7	25	33	4	7	1
DSP-30-38-4/7	30	38	4	7	1
DSP-35-43-4/7	35	43	4	7	1
DSP-40-48-4/7	40	48	4	7	1
DSP-45-53-4/7	45	53	4	7	1
DSP-50-58-4/7	50	58	4	7	1
DSP-55-63-4/7	55	63	4	7	1
DSP-60-68-4/7	60	68	4	7	1
DSP-65-73-4/7	65	73	4	7	1
DSP-70-78-4/7	70	78	4	7	1
DSP-75-83-4/7	75	83	4	7	1
DSP-80-88-4/7	80	88	4	7	1
DSP-85-93-4/7	85	93	4	7	1
DSP-90-98-4/7	90	98	4	7	1
DSP-95-103-4/7	95	103	4	7	1
DSP-100-108-4/7	100	108	4	7	1
DSP-105-117-5.5/10	105	117	4	7	1
DSP-110-122-5.5/10	110	122	4	7	1
DSP-120-132-5.5/10	120	132	4	7	1
DSP-125-137-5.5/10	125	137	5.5	10	1.5
DSP-130-142-5.5/10	130	142	4	7	1
DSP-140-152-5.5/10	140	152	4	7	1

编号 Part No.	ID ød	OD øD	H t	H h	H h1

# DSEG (MSWE K06 WNE WSL A5 GHK)

## 防尘密封

## DUST WIPER SEAL

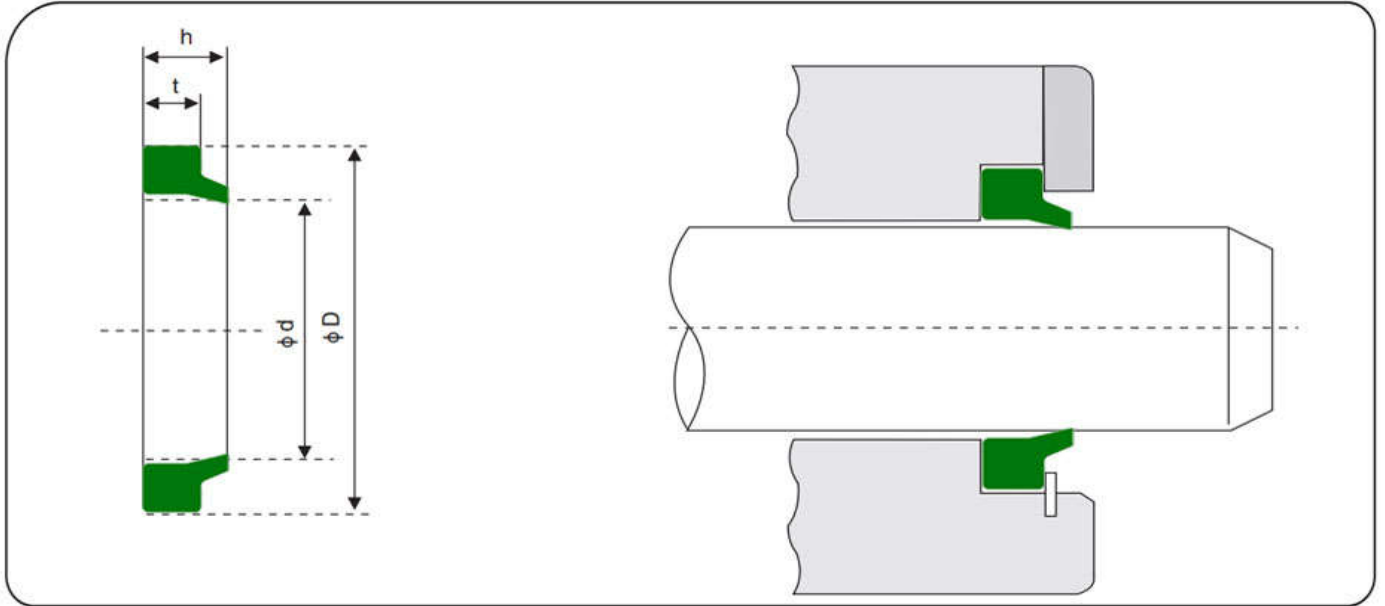

编号 Part No.	ID ød	OD øD	H t	H h
DSEG-20	20	28.6	5.3	7
DSEG-22	22	30.6	5.3	7
DSEG-25	25	33.6	5.3	7
DSEG-28	28	36.6	5.3	7
DSEG-30	30	38.6	5.3	7
DSEG-32	32	40.6	5.3	7
DSEG-35	35	43.6	5.3	7
DSEG-36	36	44.6	5.3	7
DSEG-40	40	48.6	5.3	7
DSEG-42	42	50.6	5.3	7
DSEG-45	45	53.6	5.3	7
DSEG-45A	45	55.6	5.3	7
DSEG-46	46	54.6	5.3	7
DSEG-50	50	58.6	5.3	7
DSEG-50A	50	60.6	5.3	7
DSEG-55	55	63.6	5.3	7
DSEG-55A	55	65.6	5.3	7
DSEG-56	56	66.6	5.3	7
DSEG-60	60	68.6	5.3	7
DSEG-60A	60	70.6	5.3	7
DSEG-63	63	71.6	5.3	7
DSEG-63A	63	73.6	5.3	7
DSEG-64	64	72.6	5.3	7
DSEG-65	65	73.6	5.3	7
DSEG-65A	65	75.6	5.3	7
DSEG-70	70	78.6	5.3	7
DSEG-70A	70	80.6	5.3	7
DSEG-70B	70	82.6	7.1	12
DSEG-75	75	83.6	5.3	7

编号 Part No.	ID ød	OD øD	H t	H h
DSEG-80	80	88.6	5.3	7
DSEG-80A	80	92.2	7.1	12
DSEG-85	85	93.6	5.3	7
DSEG-85A	85	97.2	7.1	12
DSEG-90	90	98.6	5.3	7
DSEG-90A	90	102.2	7.1	12
DSEG-92	92	100.6	5.3	7
DSEG-95	95	103.6	5.3	7
DSEG-100	100	108.8	5.3	7
DSEG-100A	100	112.2	7.1	12
DSEG-105	105	113.6	5.3	7
DSEG-105A	105	117.2	7.1	12
DSEG-110	110	118.6	5.3	7
DSEG-110A	110	122.2	7.1	12
DSEG-112	112	120.6	5.3	7
DSEG-115	115	123.6	5.3	7
DSEG-115A	115	125.6	5.3	7
DSEG-115B	115	127.2	7.1	12
DSEG-118	118	128.6	5.3	7
DSEG-120	120	140	9.5	14.5
DSEG-125	125	133.6	5.3	7
DSEG-125A	125	137.2	7.6	12
DSEG-125B	125	140	10.1	16
DSEG-127	127	137.1	5.3	7
DSEG-130	130	142.2	7.1	12
DSEG-140	140	148.6	5.3	7
DSEG-140A	140	152.2	7.1	12
DSEG-140B	140	155	10.1	16
DSEG-143	143	151.6	5.3	7

# DSEG (MSWE K06 WNE WSL A5 GHK)

## 防尘密封 DUST WIPER SEAL

编号 Part No	ID A	OD B	H C	GH D
DSEG-143A	143	153.6	5.3	7
DSEG-145	145	152.6	5.3	7
DSEG-145A	145	160	9.1	16
DSEG-150	150	165	10.1	16
DESG-152	152	160.6	5.3	7
DESG-155	155	167.2	7.1	12
DESG-155A	155	175	10.2	18
DESG-160	160	168.6	5.3	7
DESG-160A	160	172.2	7.6	12
DESG-160B	160	175	10.1	16
DESG-165	165	173.6	5.3	7
DESG-170	170	182.2	7.1	12
DESG-171	171	181.6	5.3	7
DESG-171A	171	183.2	7.1	12
DESG-175	175	183.6	5.3	7
DESG-180	180	200	10.2	18
DESG-185	185	193.6	5.3	7
DESG-190	190	198.6	5.3	7
DESG-195	195	210	10.1	16
DESG-200	200	220	10.2	18

编号 Part No	ID A	OD B	H C	GH D

# DSEK (DSI LPIY LPI)

防尘密封

DUST WIPER SEAL

Material  
材质

PU  
聚氨酯

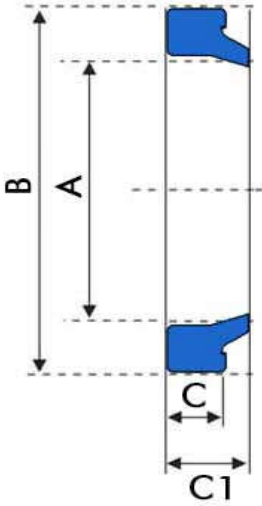

编号 Part No.	ID A	OD B	h C	H C1
DSEK-20-28-4.5/6	20	28	4.5	6
DSEK-25-33-4.5/6	25	33	4.5	6
DSEK-30-38-5/6.5	30	38	5	6.5
DSEK-35-43-5/6.5	35	43	5	6.5
DSEK-40-48-5/6.5	40	48	5	6.5
DSEK-45-53-5/6.5	45	53	5	6.5
DSEK-50-58-5/6.5	50	58	5	6.5
DSEK-53-61-5/6.5	53	61	5	6.5
DSEK-55-63-5/6.5	55	63	5	6.5
DSEK-60-68-5/6.5	60	68	5	6.5
DSEK-63-71-5/6.5	63	71	5	6.5
DSEK-65-73-5/6.5	65	73	5	6.5
DSEK-40-50-6/8	40	50	6	8
DSEK-45-55-6/8	45	55	6	8
DSEK-50-60-6/8	50	60	6	8
DSEK-55-65-6/8	55	65	6	8
DSEK-60-70-6/8	60	70	6	8
DSEK-65-75-6/8	65	75	6	8
DSEK-70-80-6/8	70	80	6	8
DSEK-75-85-6/8	75	85	6	8
DSEK-80-90-6/8	80	90	6	8
DSEK-85-95-6/8	85	95	6	8
DSEK-90-100-6/8	90	100	6	8
DSEK-95-105-6/8	95	105	6	8
DSEK-100-110-6/8	100	110	6	8
DSEK-105-115-6/8	105	115	6	8
DSEK-110-120-6/8	110	120	6	8
DSEK-120-130-6/8	120	130	6	8
DSEK-55-68-7/9.5	55	68	7	9.5
DSEK-60-73-7/9.5	60	73	7	9.5

编号 Part No.	ID A	OD B	h C	H C1
DSEK-65-78-7/9.5	65	78	7	9.5
DSEK-70-83-7/9.5	70	83	7	9.5
DSEK-75-88-7/9.5	75	88	7	9.5
DSEK-80-93-7/9.5	80	93	7	9.5
DSEK-85-98-7/9.5	85	98	7	9.5
DSEK-90-103-7/9.5	90	103	7	9.5
DSEK-95-108-7/9.5	95	108	7	9.5
DSEK-100-113-7/9.5	100	113	7	9.5
DSEK-105-118-7/9.5	105	118	7	9.5
DSEK-110-123-7/9.5	110	123	7	9.5
DSEK-120-133-7/9.5	120	133	7	9.5
DSEK-125-138-7/9.5	125	138	7	9.5
DSEK-130-143-7/9.5	130	143	7	9.5
DSEK-135-148-7/9.5	135	148	7	9.5
DSEK-140-153-7/9.5	140	153	7	9.5
DSEK-150-163-7/9.5	150	163	7	9.5
DSEK-160-173-7/9.5	160	173	7	9.5
DSEK-170-183-7/9.5	170	183	7	9.5
DSEK-93-108-6.5/10.3	93	108	6.5	10.3
DSEK-108-123-6.5/10.3	108	123	6.5	10.3
DSEK-124-139-6.5/10.3	124	139	6.5	10.3
DSEK-130-145-6.5/10.3	130	145	6.5	10.3
DSEK-140-155-6.5/10.3	140	155	6.5	10.3
DSEK-145-160-6.5/10.3	145	160	6.5	10.3
DSEK-155-170-6.5/10.3	155	170	6.5	10.3
DSEK-170-185-6.5/10.3	170	185	6.5	10.3

DLI

## 销边防尘密封

## PIN DUST WIPER SEAL

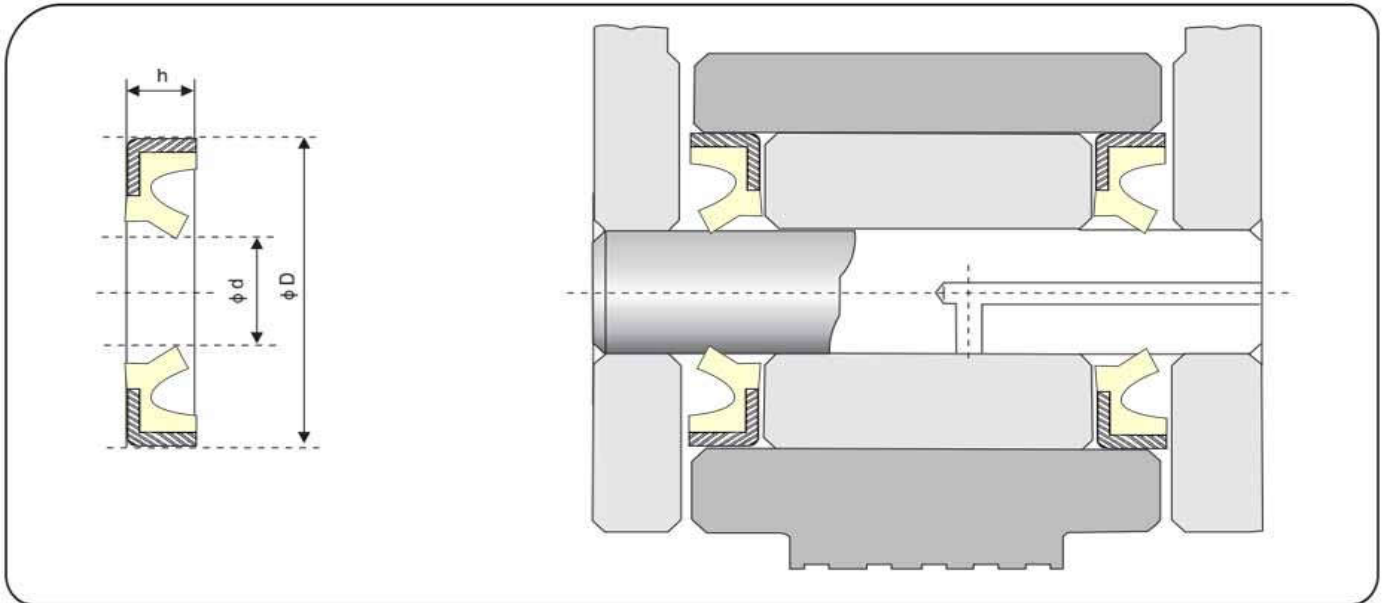

编号 Part No.	内径 ød	外径 øD	高度 h
DLI 25*35*4	25	35	4
DLI 30*40*4	30	40	4
DLI 30*45*4	30	45	4
DLI 35*45*4	35	45	4
DLI 35*45*6	35	45	6
DLI 40*50*4	40	50	4
DLI 45*52*7	45	52	7
DLI 45*55*4	45	55	4
DLI 45*55*7	45	55	7
DLI 45*59*8.5	45	59	8.5
DLI 45*60*4	45	60	4
DLI 50*60*4	50	60	4
DLI 50*60*5	50	60	5
DLI 50*60*7	50	60	7
DLI 50*63*4	50	63	4
DLI 50*63*7	50	63	7
DLI 50*63*7.5	50	63	7.5
DLI 50*64*8	50	64	8
DLI 50*65*5	50	65	5
DLI 50*65*7.5	50	65	7.5
DLI 50*65*8	50	65	8
DLI 50*72*7	50	72	7
DLI 55*64*8	55	64	8
DLI 55*65*4	55	65	4
DLI 55*68*4	55	68	4
DLI 55*68*8	55	68	8
DLI 55*69*8	55	69	8
DLI 55*70*4	55	70	4
DLI 55*70*5	55	70	5
DLI 56*68*7	56	68	7

编号 Part No.	内径 ød	外径 øD	高度 h
DLI 58*70*5	58	70	5
DLI 60*70*4	60	70	4
DLI 60*70*7	60	70	7
DLI 60*74*8	60	74	8
DLI 60*75*4	60	75	4
DLI 60*75*5	60	75	5
DLI 60*75*6	60	75	6
DLI 60*75*8	60	75	8
DLI 60*80*4	60	80	4
DLI 60*80*5	60	80	5
DLI 60*80*6	60	80	6
DLI 63*75*7	63	75	7
DLI 63*78*7	63	78	7
DLI 65*75*4	65	75	4
DLI 65*75*5	65	75	5
DLI 65*75*7	65	75	7
DLI 65*79*8	65	79	8
DLI 65*80*4	65	80	4
DLI 65*80*5	65	80	5
DLI 65*80*6	65	80	6
DLI 65*80*8	65	80	8
DLI 70*80*4	70	80	4
DLI 70*80*5	70	80	5
DLI 70*80*6	70	80	6
DLI 70*80*7	70	80	7
DLI 70*84*8	70	84	8
DLI 70*85*4	70	85	4
DLI 70*85*5	70	85	5
DLI 70*85*6	70	85	6
DLI 70*85*7	70	85	7

DLI

## 销边防尘密封 PIN DUST WIPER SEAL

编号 Part No	内径 ød	外径 øD	高度 h
DLI 70*85*8	70	85	8
DLI 70*90*7.5	70	90	7.5
DLI 71*86*5	71	86	5
DLI 71*86*6	71	86	6
DLI 75*89*8	75	89	8
DLI 75*90*4	75	90	4
DLI 75*90*5	75	90	5
DLI 75*90*6	75	90	6
DLI 75*90*7.5	75	90	7.5
DLI 75*90*8	75	90	8
DLI 75*95*4	75	95	4
DLI 80*100*10	80	100	10
DLI 80*100*6	80	100	6
DLI 80*100*7	80	100	7
DLI 80*90*5	80	90	5
DLI 80*90*6	80	90	6
DLI 80*90*7	80	90	7
DLI 80*93*7.5	80	93	7.5
DLI 80*94*8	80	94	8
DLI 80*95*4	80	95	4
DLI 80*95*4.5	80	95	4.5
DLI 80*95*5	80	95	5
DLI 80*95*6	80	95	6
DLI 80*95*8	80	95	8
DLI 85*100*4	85	100	4
DLI 85*100*5	85	100	5
DLI 85*100*6	85	100	6
DLI 85*99*8	85	99	8
DLI 90*100*7	90	100	7
DLI 90*104*8	90	104	8
DLI 90*105*4	90	105	4
DLI 90*105*5	90	105	5
DLI 90*105*6	90	105	6
DLI 90*105*8	90	105	8
DLI 90*106*8	90	106	8
DLI 90*107*5	90	107	5
DLI 90*110*8	90	110	8
DLI 95*109*8	95	109	8
DLI 95*110*4	95	110	4
DLI 95*110*5	95	110	5
DLI 95*110*6	95	110	6
DLI 95*110*8	95	110	8
DLI 100*110*4	100	110	4
DLI 100*110*7	100	110	7
DLI 100*114*8	100	114	8
DLI 100*115*4	100	115	4
DLI 100*115*5	100	115	5
DLI 100*115*6	100	115	6
DLI 100*115*7	100	115	7
DLI 100*115*8	100	115	8
DLI 100*120*10	100	120	10
DLI 100*120*8	100	120	8

编号 Part No	内径 ød	外径 øD	高度 h
DLI 100*130*5	100	130	5
DLI 105*120*10	105	120	10
DLI 105*121*8	105	121	8
DLI 105*125*5	105	125	5
DLI 110*120*7	110	120	7
DLI 110*125*4	110	125	4
DLI 110*125*5	110	125	5
DLI 110*125*8	110	125	8
DLI 110*126*8	110	126	8
DLI 110*130*10	110	130	10
DLI 110*130*8	110	130	8
DLI 110*135*8	110	135	8
DLI 110*140*10	110	140	10
DLI 110*140*8	110	140	8
DLI 115*130*8	115	130	8
DLI 115*131*8	115	131	8
DLI 115*135*8	115	135	8
DLI 120*130*7	120	130	7
DLI 120*135*4	120	135	4
DLI 120*135*8	120	135	8
DLI 120*136*8	120	136	8
DLI 120*140*10	120	140	10
DLI 120*140*8	120	140	8
DLI 120*150*12	120	150	12
DLI 125*140*4	125	140	4
DLI 125*140*8	125	140	8
DLI 125*145*8	125	145	8
DLI 130*140*7	130	140	7
DLI 130*145*6	130	145	6
DLI 130*145*8	130	145	8
DLI 130*150*10	130	150	10
DLI 130*150*8	130	150	8
DLI 130*154*8	130	154	8
DLI 130*155*8	130	155	8
DLI 130*160*10	130	160	10
DLI 130*160*12	130	160	12
DLI 140*155*8	140	155	8
DLI 140*160*10	140	160	10
DLI 140*160*8	140	160	8
DLI 140*164*8	140	164	8
DLI 140*165*8	140	165	8
DLI 140*170*12	140	170	12
DLI 150*160*6	150	160	6
DLI 150*165*8	150	165	8
DLI 150*170*8	150	170	8
DLI 150*180*8	150	180	8
DLI 160*180*10	160	180	10
DLI 160*180*8	160	180	8
DLI 160*190*10	160	190	10
DLI 170*200*10	170	200	10
DLI 180*200*10	180	200	10
DLI 200*235*7.5	200	235	7.5



## 防尘密封

## DUST WIPER SEAL

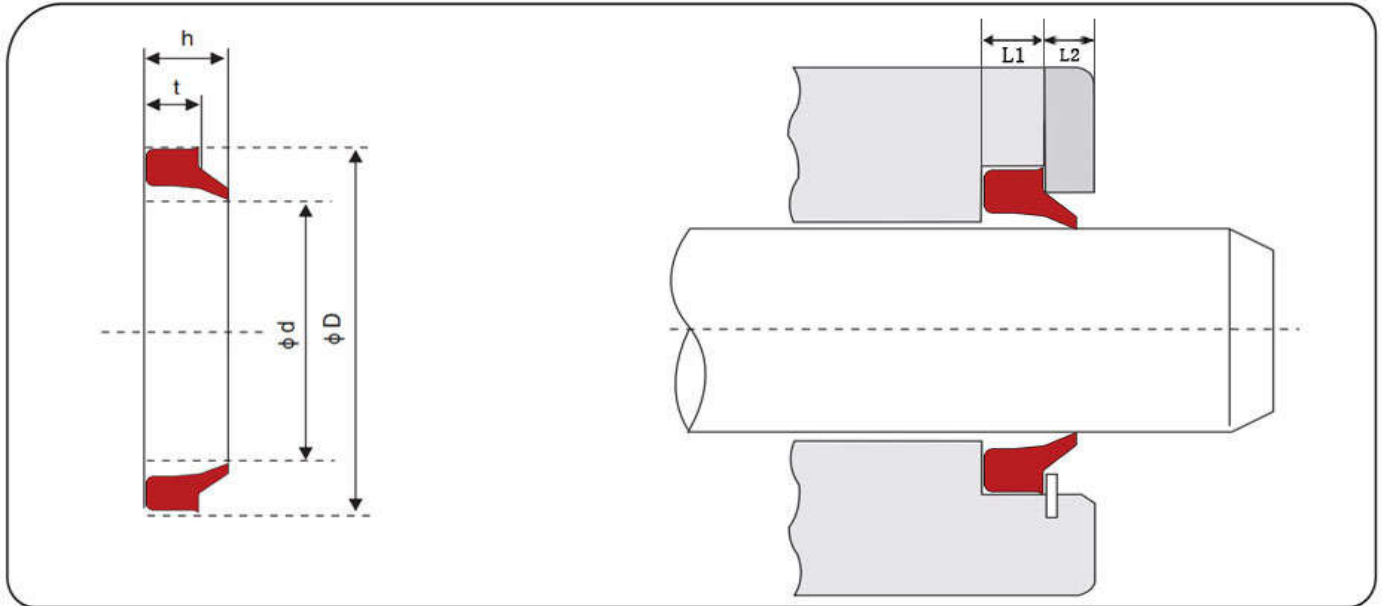

编号 Part No.	内径 $\phi d$	外径 $\phi D$	槽宽1 L1	槽宽2 L2
38 8*15.3*3.2/4.9	8	15.3	3.2	4.9
38 18*24*5/7	18	24	5	7
38 20*28*5/8	20	28	5	8
38 22*30*5/8	22	30	5	8
38 25*33*5/8	25	33	5	8
38 28*36*5/8	28	36	5	8
38 30*38*5/8	30	38	5	8
38 30*41.2*7.5/10	30	41.2	7.5	10
38 32*40*5/8	32	40	5	8
38 35*43*5/8	35	43	5	8
38 36*44*5/8	36	44	5	8
38 40*48*5/8	40	48	5	8
38 40*50.6*5.3/7	40	50.6	5.3	7
38 41.28*49.28*5/8	41.28	49.28	5	8
38 45*53*5/8	45	53	5	8
38 45*55.6*5.3/7	45	55.6	5.3	7
38 50*58*5/8	50	58	5	8
38 50*58.6*5.3/7	50	58.6	5.3	7
38 50*60.6*5.3/7	50	60.6	5.3	7
38 55*65*6.3/10	55	65	6.3	10
38 55*65.6*5.3/7	55	65.6	5.3	7
38 56*66*6.3/10	56	66	6.3	10
38 56*66.6*5.3/7	56	66.6	5.3	7
38 60*70*5.3/7	60	70	5.3	7
38 60*70*6.3/10	60	70	6.3	10
38 60*70.6*5.3/7	60	70.6	5.3	7
38 63*73*6.3/10	63	73	6.3	10
38 63*73.6*5.3/7	63	73.6	5.3	7
38 65*75*6.3/10	65	75	6.3	10
38 65*75.6*5.3/7	65	75.6	5.3	7

编号 Part No.	内径 $\phi d$	外径 $\phi D$	槽宽1 L1	槽宽2 L2
38 70*80*6.3/10	70	80	6.3	10
38 70*80.6*5.3/7	70	80.6	5.3	7
38 70*82.2*7.2/12	70	82.2	7.2	12
38 75*83.6*5.3/7	75	83.6	5.3	7
38 75*85*6.3/10	75	85	6.3	10
38 75*87.2*7.2/12	75	87.2	7.2	12
38 80*90*6.3/10	80	90	6.3	10
38 80*91*7.5/11	80	91	7.5	11
38 80*92.2*7.2/12	80	92.2	7.2	12
38 82.6*92.2*5.3/7.1	82.6	92.2	5.3	7.1
38 85*93.6*5.3/7	85	93.6	5.3	7
38 85*97.2*7.2/12	85	97.2	7.2	12
38 85*98*7.5/11.5	85	98	7.5	11.5
38 88*100.2*7.2/12	88	100.2	7.2	12
38 90*100*6.3/10	90	100	6.3	10
38 90*102.2*7.2/12	90	102.2	7.2	12
38 92*112*7/11	92	112	7	11
38 95*107.2*7.2/12	95	107.2	7.2	12
38 100*110.6*5.3/7	100	110.6	5.3	7
38 100*112.2*7.2/12	100	112.2	7.2	12
38 100*115*9.5/14	100	115	9.5	14
38 101.6*116.6*9.5/14	101.6	116.6	9.5	14
38 105*113*5/8	105	113	5	8
38 105*120*7.2/12	105	120	7.2	12
38 110*122.2*7.2/12	110	122.2	7.2	12
38 110*125*9.5/14	110	125	9.5	14
38 115*127.2*7.2/12	115	127.2	7.2	12
38 120*132.2*7.2/12	120	132.2	7.2	12
38 120*135*9.5/14	120	135	9.5	14
38 125*133*5.3/7	125	133	5.3	7

## 防尘密封 DUST WIPER SEAL

编号 Part No	内径 ∅d	外径 ∅D	槽宽1 I1	槽宽2 I2
38 125*137.2*7.7/12	125	137.2	7.7	12
38 125*140*10.2/16	125	140	10.2	16
38 125*140*9.5/14	125	140	9.5	14
38 128*143*9.5/14	128	143	9.5	14
38 130*142.2*7.2/12	130	142.2	7.2	12
38 130*145*10.2/16	130	145	10.2	16
38 132*144.2*7.2/12	132	144.2	7.2	12
38 135*147.2*7.2/12	135	147.2	7.2	12
38 135*150*9.5/14	135	150	9.5	14
38 140*148.6*5.3/7	140	148.6	5.3	7
38 140*152.2*7.7/12	140	152.2	7.7	12
38 140*155*10.2/16	140	155	10.2	16
38 140*155*9.5/14	140	155	9.5	14
38 145*153.6*5.3/7	145	153.6	5.3	7
38 145*160*9.5/14	145	160	9.5	14
38 150*162.2*7.7/12	150	162.2	7.7	12
38 150*165*10.2/16	150	165	10.2	16
38 150*165*7.2/12	150	165	7.2	12
38 150*166*8/12	150	166	8	12
38 155*163*5/8	155	163	5	8
38 155*167.2*7.7/12	155	167.2	7.7	12
38 155*175*10.2/18	155	175	10.2	18
38 160*172.2*7.7/12	160	172.2	7.7	12
38 160*175*10.2/16	160	175	10.2	16
38 160*175*9.5/14	160	175	9.5	14
38 165*180*9.5/14	165	180	9.5	14
38 170*180.6*5.3/7	170	180.6	5.3	7
38 170*182.2*7.7/12	170	182.2	7.7	12
38 170*185*9.5/14	170	185	9.5	14
38 177*192*9.5/14	177	192	9.5	14
38 180*195*9.5/14	180	195	9.5	14
38 180*200*10.2/18	180	200	10.2	18
38 185*200*10.2/16	185	200	10.2	16
38 185*205*10.2/18	185	205	10.2	18
38 190*198.6*5.3/7	190	198.6	5.3	7
38 190*205*9.5/14	190	205	9.5	14
38 190*210*10.2/18	190	210	10.2	18
38 195*210*10.2/16	195	210	10.2	16
38 200*208.6*5.3/7	200	208.6	5.3	7
38 200*215*9.5/14	200	215	9.5	14
38 200*220*10.2/18	200	220	10.2	18
38 205*213.6*5.3/7	205	213.6	5.3	7
38 205*220*9.5/14	205	220	9.5	14
38 210*225*9.5/14	210	225	9.5	14
38 210*226*8/12	210	226	8	12
38 210*230*10.2/18	210	230	10.2	18
38 212*232*12.5/18	212	232	12.5	18
38 220*235*10.2/16	220	235	10.2	16
38 220*240*10.2/18	220	240	10.2	18
38 220*240*12.5/18	220	240	12.5	18
38 225*240*9.5/14	225	240	9.5	14
38 225*245*10.2/18	225	245	10.2	18

编号 Part No	内径 ∅d	外径 ∅D	槽宽1 I1	槽宽2 I2
38 230*238.6*5.3/7	230	238.6	5.3	7
38 230*245*9.5/14	230	245	9.5	14
38 230*246*7.5/12	230	246	7.5	12
38 230*250*10.2/18	230	250	10.2	18
38 235*255*10.2/18	235	255	10.2	18
38 240*255*9.5/14	240	255	9.5	14
38 240*260*10.2/18	240	260	10.2	18
38 240*260*12.5/18	240	260	12.5	18
38 245*265*12.5/18	245	265	12.5	18
38 250*270*10.2/18	250	270	10.2	18
38 250*270*12.5/18	250	270	12.5	18
38 255*270*9.5/14	255	270	9.5	14
38 260*275*9.5/14	260	275	9.5	14
38 260*280*10.2/18	260	280	10.2	18
38 265*280*10.2/16	265	280	10.2	16
38 265*285*10.2/15	265	285	10.2	15
38 270*278.6*5.3/7	270	278.6	5.3	7
38 270*286*7.5/12	270	286	7.5	12
38 270*290*10.2/15	270	290	10.2	15
38 275*295*10.2/15	275	295	10.2	15
38 280*295*9.5/14	280	295	9.5	14
38 280*300*10.2/15	280	300	10.2	15
38 285*300*9.5/14	285	300	9.5	14
38 285*305*12.5/18	285	305	12.5	18
38 288*308*10.2/15	288	308	10.2	15
38 290*310*12.5/18	290	310	12.5	18
38 295*315*12.5/18	295	315	12.5	18
38 300*316*7.5/12	300	316	7.5	12
38 300*320*10.2/18	300	320	10.2	18
38 300*320*12.5/18	300	320	12.5	18
38 305*325*12.5/18	305	325	12.5	18
38 320*340*10.2/18	320	340	10.2	18
38 325*345*10.2/18	325	345	10.2	18
38 330*346*7.5/12	330	346	7.5	12
38 335*355*10.2/18	335	355	10.2	18
38 340*360*10.2/18	340	360	10.2	18
38 350*370*10.2/18	350	370	10.2	18
38 355*375*10.2/18	355	375	10.2	18
38 360*380*10.2/18	360	380	10.2	18
38 370*390*10.2/18	370	390	10.2	18
38 370*390*12.5/18	370	390	12.5	18
38 380*400*12.5/18	380	400	12.5	18
38 390*410*10.2/18	390	410	10.2	18
38 390*410*12.5/18	390	410	12.5	18
38 395*415*10.2/18	395	415	10.2	18
38 400*420*10.2/18	400	420	10.2	18
38 415*435*10.2/18	415	435	10.2	18
38 445*465*10.2/18	445	465	10.2	18
38 455*475*10.2/18	455	475	10.2	18
38 460*490*15/25	460	490	15	25
38 470*490*10.2/18	470	490	10.2	18

防尘密封  
DUST WIPER SEAL

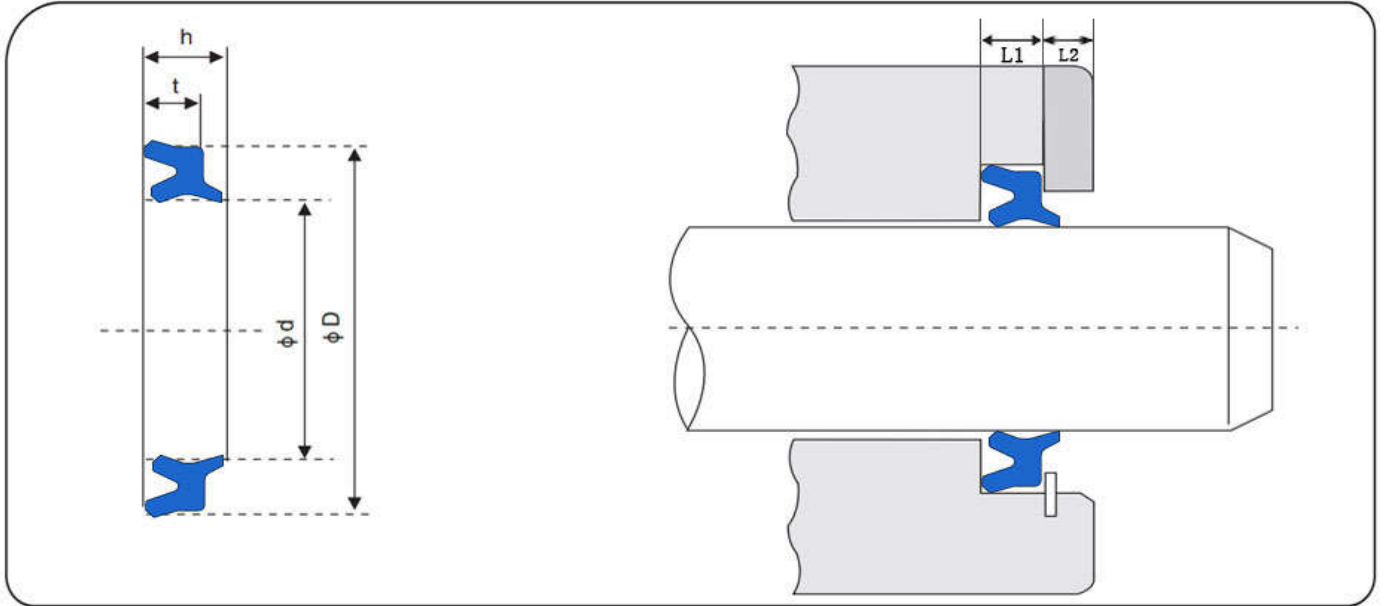

编号 Part No.	内径 ød	外径 øD	槽宽1 L1	槽宽2 L2
839 12*18*4/7	12	18	4	7
839 14*20*4/7	14	20	4	7
839 15*22*3.8/6	15	22	3.8	6
839 18*24*4/7	18	24	4	7
839 20*26*4/6	20	26	4	6
839 22*28*4/7	22	28	4	7
839 25*31*4/7	25	31	4	7
839 28*36*5/8	28	36	5	8
839 30*38*5/8	30	38	5	8
839 32*40*5/8	32	40	5	8
839 36*44*5/8	36	44	5	8
839 40*48*5/8	40	48	5	8
839 45*53*5/8	45	53	5	8
839 50*58*5/8	50	58	5	8
839 55*65*6/9.7	55	65	6	9.7
839 56*66*6/9.7	56	66	6	9.7
839 60*70*6/9.7	60	70	6	9.7
839 65*75*6/9.7	65	75	6	9.7
839 70*78.6*5.3/7	70	78.6	5.3	7
839 70*80*6/9.7	70	80	6	9.7
839 90*100*6/9.7	90	100	6	9.7
839 110*125*8.5/13	110	125	8.5	13
839 130*142*8.2/11	130	142	8.2	11
839 140*155*8.5/13	140	155	8.5	13
839 150*165*8.5/13	150	165	8.5	13
839 180*196*9.5/14	180	196	9.5	14

编号 Part No.	内径 ød	外径 øD	槽宽1 L1	槽宽2 L2

WR

导向/耐磨环

GUIDE RING WEAR RING

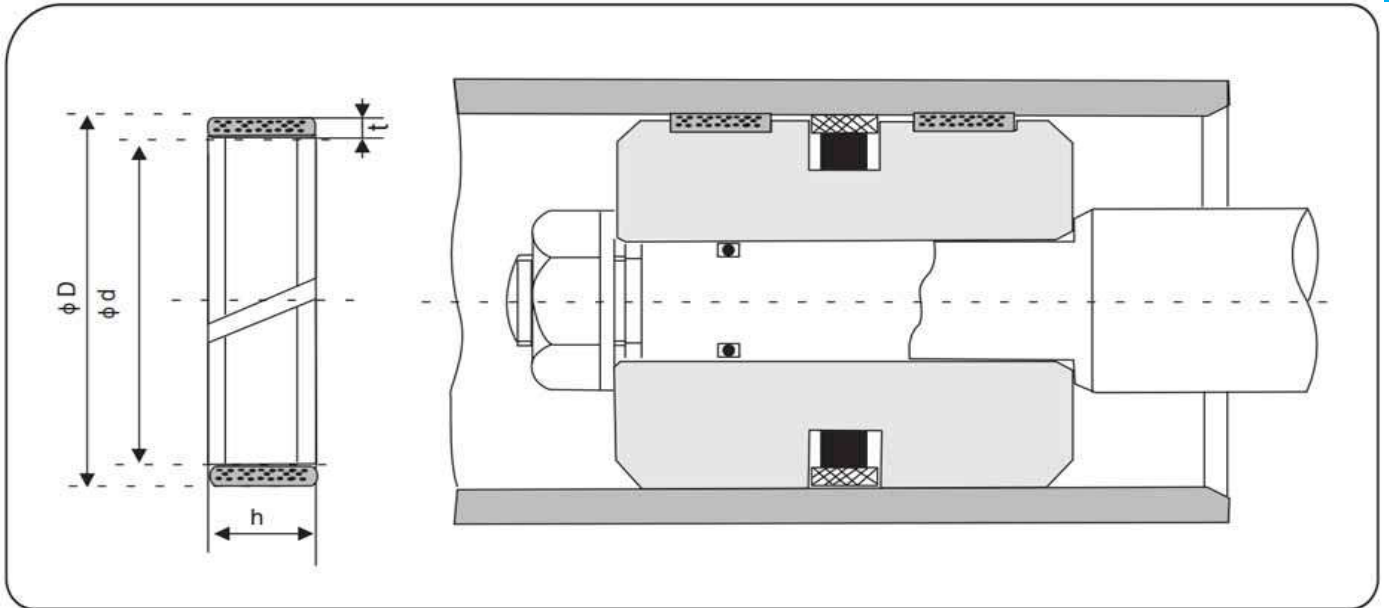

编号 Part No.	外径 øD	内径 ød	高度 h
WR 75*70*6	75	70	6
WR 80*75*6	80	75	6
WR 85*80*6	85	80	6
WR 90*85*6	90	85	6
WR 95*90*6	95	90	6
WR 100*94*6	100	94	6
WR 100*95*6	100	95	6
WR 105*100*6	105	100	6
WR 110*104*6	110	104	6
WR 110*105*6	110	105	6
WR 120*114*6	120	114	6
WR 55*50*8	55	50	8
WR 60*55*8	60	55	8
WR 75*70*8	75	70	8
WR 80*75*8	80	75	8
WR 85*80*8	85	80	8
WR 90*85*8	90	85	8
WR 95*90*8	95	90	8
WR 100*95*8	100	95	8
WR 105*100*8	105	100	8
WR 110*105*8	110	105	8
WR 115*110*8	115	110	8
WR 120*115*8	120	115	8
WR 125*120*8	125	120	8
WR 130*125*8	130	125	8
WR 135*130*8	135	130	8
WR 140*135*8	140	135	8
WR 145*140*8	145	140	8
WR 150*145*8	150	145	8
WR 40*35*9.5	40	35	9.5

编号 Part No.	外径 øD	内径 ød	高度 h
WR 50*45*9.5	50	45	9.5
WR 55*50*9.5	55	50	9.5
WR 60*55*9.5	60	55	9.5
WR 70*65*9.5	70	65	9.5
WR 75*69*9.5	75	69	9.5
WR 75*70*9.5	75	70	9.5
WR 80*74*9.5	80	74	9.5
WR 80*75*9.5	80	75	9.5
WR 85*80*9.5	85	80	9.5
WR 90*81*9.5	90	81	9.5
WR 90*84*9.5	90	84	9.5
WR 90*85*9.5	90	85	9.5
WR 95*86*9.5	95	86	9.5
WR 95*90*9.5	95	90	9.5
WR 100*91*9.5	100	91	9.5
WR 100*95*9.5	100	95	9.5
WR 105*96*9.5	105	96	9.5
WR 105*100*9.5	105	100	9.5
WR 110*101*9.5	110	101	9.5
WR 110*105*9.5	110	105	9.5
WR 115*106*9.5	115	106	9.5
WR 115*110*9.5	115	110	9.5
WR 120*111*9.5	120	111	9.5
WR 120*115*9.5	120	115	9.5
WR 125*118*9.5	125	118	9.5
WR 125*119*9.5	125	119	9.5
WR 125*120*9.5	125	120	9.5
WR 130*120*9.5	130	120	9.5
WR 130*123*9.5	130	123	9.5
WR 130*125*9.5	130	125	9.5

WR

## 导向/耐磨环

### GUIDE RING WEAR RING

编号 Part No	外径 øD	内径 ød	高度 h
WR 135*125*9.5	135	125	9.5
WR 135*128*9.5	135	128	9.5
WR 135*130*9.5	135	130	9.5
WR 140*128*9.5	140	128	9.5
WR 140*133*9.5	140	133	9.5
WR 140*135*9.5	140	135	9.5
WR 145*138*9.5	145	138	9.5
WR 145*140*9.5	145	140	9.5
WR 150*145*9.5	150	145	9.5
WR 160*155*9.5	160	155	9.5
WR 170*164*9.5	170	164	9.5
WR 170*165*9.5	170	165	9.5
WR 85*79*12.5	85	79	12.5
WR 90*81*12.5	90	81	12.5
WR 90*84*12.5	90	84	12.5
WR 95*86*12.5	95	86	12.5
WR 95*89*12.5	95	89	12.5
WR 100*91*12.5	100	91	12.5
WR 100*94*12.5	100	94	12.5
WR 105*96*12.5	105	96	12.5
WR 110*101*12.5	110	101	12.5
WR 110*104*12.5	110	104	12.5
WR 140*128*12.5	140	128	12.5
WR 50*45*15	50	45	15
WR 55*50*15	55	50	15
WR 60*54*15	60	54	15
WR 60*55*15	60	55	15
WR 65*60*15	65	60	15
WR 70*64*15	70	64	15
WR 70*65*15	70	65	15
WR 75*69*15	75	69	15
WR 75*70*15	75	70	15
WR 80*72*15	80	72	15
WR 80*74*15	80	74	15
WR 80*75*15	80	75	15
WR 85*77*15	85	77	15
WR 85*79*15	85	79	15
WR 85*80*15	85	80	15
WR 90*82*15	90	82	15
WR 90*84*15	90	84	15
WR 90*85*15	90	85	15
WR 95*87*15	95	87	15
WR 95*89*15	95	89	15
WR 95*90*15	95	90	15
WR 100*92*15	100	92	15
WR 100*94*15	100	94	15
WR 100*95*15	100	95	15
WR 105*97*15	105	97	15
WR 105*99*15	105	99	15

编号 Part No	外径 øD	内径 ød	高度 h
WR 105*100*15	105	100	15
WR 110*101*15	110	101	15
WR 110*102*15	110	102	15
WR 110*104*15	110	104	15
WR 110*105*15	110	105	15
WR 115*106*15	115	106	15
WR 115*107*15	115	107	15
WR 115*109*15	115	109	15
WR 115*110*15	115	110	15
WR 120*111*15	120	111	15
WR 120*112*15	120	112	15
WR 120*114*15	120	114	15
WR 120*115*15	120	115	15
WR 125*118*15	125	118	15
WR 125*119*15	125	119	15
WR 125*120*15	125	120	15
WR 130*120*15	130	120	15
WR 130*123*15	130	123	15
WR 130*125*15	130	125	15
WR 135*125*15	135	125	15
WR 135*128*15	135	128	15
WR 135*130*15	135	130	15
WR 140*128*15	140	128	15
WR 140*133*15	140	133	15
WR 140*135*15	140	135	15
WR 145*138*15	145	138	15
WR 145*140*15	145	140	15
WR 150*143*15	150	143	15
WR 150*145*15	150	145	15
WR 160*148*15	160	148	15
WR 160*153*15	160	153	15
WR 160*155*15	160	155	15
WR 165*157*15	165	157	15
WR 165*160*15	165	160	15
WR 170*162*15	170	162	15
WR 170*164*15	170	164	15
WR 170*165*15	170	165	15
WR 175*167*15	175	167	15
WR 175*170*15	175	170	15
WR 180*172*15	180	172	15
WR 180*174*15	180	174	15
WR 180*175*15	180	175	15
WR 190*182*15	190	182	15
WR 190*184*15	190	184	15
WR 190*185*15	190	185	15
WR 200*195*15	200	195	15
WR 140*128*17.5	140	128	17.5
WR 150*138*17.5	150	138	17.5
WR 160*148*17.5	160	148	17.5

# WR

## 导向/耐磨环

### GUIDE RING WEAR RING

编号 Part No	外径 øD	内径 ød	高度 h
WR 60*55*20	60	55	20
WR 63*58*20	63	58	20
WR 65*60*20	65	60	20
WR 70*64*20	70	64	20
WR 70*65*20	70	65	20
WR 75*70*20	75	70	20
WR 80*74*20	80	74	20
WR 80*75*20	80	75	20
WR 85*79*20	85	79	20
WR 90*84*20	90	84	20
WR 95*89*20	95	89	20
WR 100*94*20	100	94	20
WR 115*110*20	115	110	20
WR 120*115*20	120	115	20
WR 125*120*20	125	120	20
WR 130*123*20	130	123	20
WR 130*125*20	130	125	20
WR 135*128*20	135	128	20
WR 140*133*20	140	133	20
WR 140*135*20	140	135	20
WR 145*138*20	145	138	20
WR 150*143*20	150	143	20
WR 150*145*20	150	145	20
WR 160*148*20	160	148	20
WR 160*153*20	160	153	20
WR 170*158*20	170	158	20
WR 170*162*20	170	162	20
WR 180*175*20	180	175	20
WR 150*143*21	150	143	21
WR 100*94*22	100	94	22
WR 110*104*22	110	104	22
WR 120*114*22	120	114	22
WR 150*143*22	150	143	22
WR 180*172*22.5	180	172	22.5
WR 185*173*22.5	185	173	22.5
WR 190*182*22.5	190	182	22.5
WR 200*188*22.5	200	188	22.5
WR 200*192*22.5	200	192	22.5
WR 60*54*25	60	54	25
WR 70*64*25	70	64	25
WR 75*69*25	75	69	25
WR 75*70*25	75	70	25
WR 80*74*25	80	74	25
WR 90*84*25	90	84	25
WR 95*89*25	95	89	25
WR 100*94*25	100	94	25
WR 110*104*25	110	104	25
WR 125*120*25	125	120	25
WR 130*125*25	130	125	25

编号 Part No	外径 øD	内径 ød	高度 h
WR 135*128*25	135	128	25
WR 135*130*25	135	130	25
WR 140*135*25	140	135	25
WR 165*157*25	165	157	25
WR 170*162*25	170	162	25
WR 175*167*25	175	167	25
WR 190*182*25	190	182	25
WR 225*213*25	225	213	25
WR 225*217*25	225	217	25
WR 80*74*30	80	74	30
WR 90*84*30	90	84	30
WR 100*94*30	100	94	30
WR 110*104*30	110	104	30
WR 120*114*30	120	114	30
WR 130*123*30	130	123	30
WR 165*159*30	165	159	30
WR 120*114*35	120	114	35
WR 140*133*35	140	133	35
WR 150*143*35	150	143	35
WR 160*153*35	160	153	35
WR 140*133*40	140	133	40
WR 150*143*40	150	143	40
WR 160*153*40	160	153	40
WR 170*163*40	170	163	40
WR 150*143*45	150	143	45
WR 160*153*45	160	153	45
WR 180*172*45	180	172	45
WR 190*182*45	190	182	45
WR 200*192*45	200	192	45
WR 170*162*50	170	162	50
WR 225*217*50	225	217	50

# KZS (KZT)

## 导向/耐磨环

### GUIDE RING WEAR RING

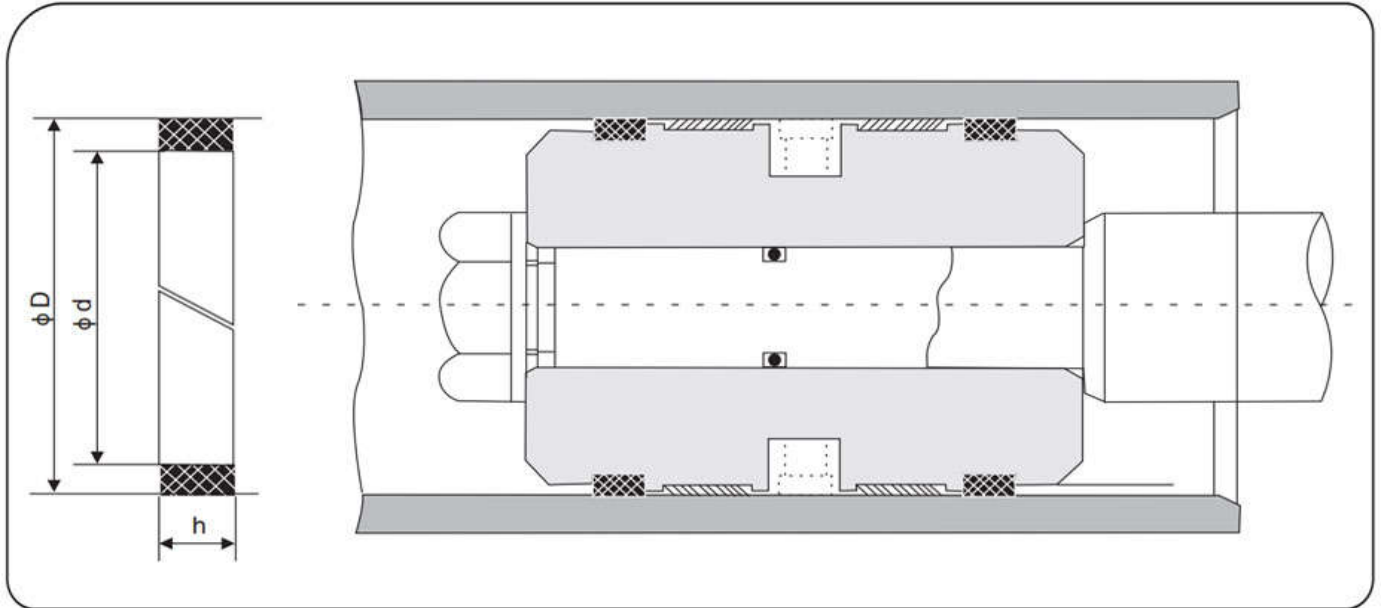

编号 Part No.	外径 øD	内径 ød	高度 h
KZS 70*4	70	62	4
KZS 75*4	75	67	4
KZS 80*4	80	72	4
KZS 85*4	85	77	4
KZS 90*4	90	82	4
KZS 95*4	95	87	4
KZS 100*4	100	92	4
KZS 105*4	105	97	4
KZS 110*4	110	102	4
KZS 115*4	115	107	4
KZS 120*4	120	112	4
KZS 125*4	125	117	4
KZS 130*4	130	122	4
KZS 135*4	135	127	4
KZS 140*4	140	132	4
KZS 145*4	145	137	4
KZS 150*4	150	142	4
KZS 65*6	65	57	6
KZS 70*6	70	62	6
KZS 75*6	75	67	6
KZS 80*6	80	72	6
KZS 85*6	85	77	6
KZS 90*6	90	82	6
KZS 95*6	95	87	6
KZS 100*6	100	92	6
KZS 105*6	105	97	6
KZS 110*6	110	102	6
KZS 115*6	115	107	6
KZS 120*6	120	112	6
KZS 125*6	125	117	6

编号 Part No.	外径 øD	内径 ød	高度 h
KZS 130*6	130	122	6
KZS 135*6	135	127	6
KZS 140*6	140	132	6
KZS 145*6	145	137	6
KZS 150*6	150	142	6
KZS 155*6	155	147	6
KZS 160*6	160	152	6
KZS 165*6	165	157	6
KZS 170*6	170	162	6
KZS 175*6	175	167	6
KZS 180*6	180	172	6
KZS 185*6	185	177	6
KZS 190*6	190	182	6
KZS 200*6	200	192	6
KZS 70*8	70	62	8
KZS 75*8	75	67	8
KZS 80*8	80	72	8
KZS 85*8	85	77	8
KZS 90*8	90	82	8
KZS 95*8	95	88	8
KZS 100*8	100	92	8
KZS 105*8	105	97	8
KZS 110*8	110	102	8
KZS 115*8	115	107	8
KZS 120*8	120	112	8
KZS 125*8	125	117	8
KZS 130*8	130	122	8
KZS 135*8	135	127	8
KZS 140*8	140	132	8
KZS 145*8	145	137	8

# KZS

## 导向/耐磨环

### GUIDE RING WEAR RING

编号 Part No	外径 $\varnothing D$	内径 $\varnothing d$	高度 h
KZS 150*8	150	142	8
KZS 155*8	155	147	8
KZS 160*8	160	152	8
KZS 165*8	165	157	8
KZS 170*8	170	162	8
KZS 175*8	175	167	8
KZS 180*8	180	172	8
KZS 185*8	185	177	8
KZS 190*8	190	182	8
KZS 195*8	195	187	8
KZS 200*8	200	192	8
KZS 210*8	210	202	8
KZS 215*8	215	207	8
KZS 220*8	220	212	8
KZS 225*8	225	217	8
KZS 230*8	230	222	8
KZS 240*8	240	232	8
KZS 250*8	250	242	8
KZS 260*8	260	252	8
KZS 270*8	270	262	8
KZS 280*8	280	272	8
KZS 290*8	290	282	8
KZS 300*8	300	292	8
KZS 170*9	170	162	9
KZS 70*9.7	70	62	9.7
KZS 75*9.7	75	67	9.7
KZS 80*9.7	80	72	9.7
KZS 85*9.7	85	77	9.7
KZS 90*9.7	90	82	9.7
KZS 95*9.7	95	87	9.7
KZS 100*9.7	100	92	9.7
KZS 105*9.7	105	97	9.7
KZS 110*9.7	110	102	9.7
KZS 115*9.7	115	107	9.7
KZS 120*9.7	120	112	9.7
KZS 125*9.7	125	117	9.7
KZS 130*9.7	130	122	9.7
KZS 135*9.7	135	127	9.7
KZS 140*9.7	140	132	9.7
KZS 145*9.7	145	137	9.7
KZS 150*9.7	150	142	9.7
KZS 155*9.7	155	147	9.7
KZS 160*9.7	160	152	9.7
KZS 165*9.7	165	157	9.7
KZS 170*9.7	170	162	9.7
KZS 175*9.7	175	167	9.7
KZS 180*9.7	180	172	9.7
KZS 185*9.7	185	177	9.7
KZS 190*9.7	190	182	9.7

编号 Part No	外径 $\varnothing D$	内径 $\varnothing d$	高度 h
KZS 195*9.7	195	187	9.7
KZS 200*9.7	200	192	9.7
KZS 205*9.7	205	197	9.7
KZS 210*9.7	210	202	9.7
KZS 215*9.7	215	207	9.7
KZS 220*9.7	220	192	9.7
KZS 225*9.7	225	197	9.7
KZS 230*9.7	230	222	9.7
KZS 240*9.7	240	232	9.7
KZS 250*9.7	250	242	9.7
KZS 260*9.7	260	252	9.7
KZS 270*9.7	270	262	9.7
KZS 280*9.7	280	272	9.7
KZS 290*9.7	290	282	9.7
KZS 300*9.7	300	292	9.7
KZS 70*15	70	62	15
KZS 75*15	75	67	15
KZS 80*15	80	72	15
KZS 85*15	85	77	15
KZS 90*15	90	82	15
KZS 95*15	95	87	15
KZS 100*15	100	92	15
KZS 105*15	105	97	15
KZS 110*15	110	102	15
KZS 115*15	115	107	15
KZS 120*15	120	112	15
KZS 125*15	125	117	15
KZS 130*15	130	122	15
KZS 135*15	135	127	15
KZS 140*15	140	132	15
KZS 145*15	145	137	15
KZS 150*15	150	142	15
KZS 155*15	155	147	15
KZS 160*15	160	152	15
KZS 165*15	165	157	15
KZS 170*15	170	162	15
KZS 175*15	175	167	15
KZS 180*15	180	172	15
KZS 185*15	185	177	15
KZS 190*15	190	182	15
KZS 195*15	195	187	15
KZS 200*15	200	192	15



# RYR (RYT roll)

## 导向/耐磨环

### GUIDE RING WEAR RING

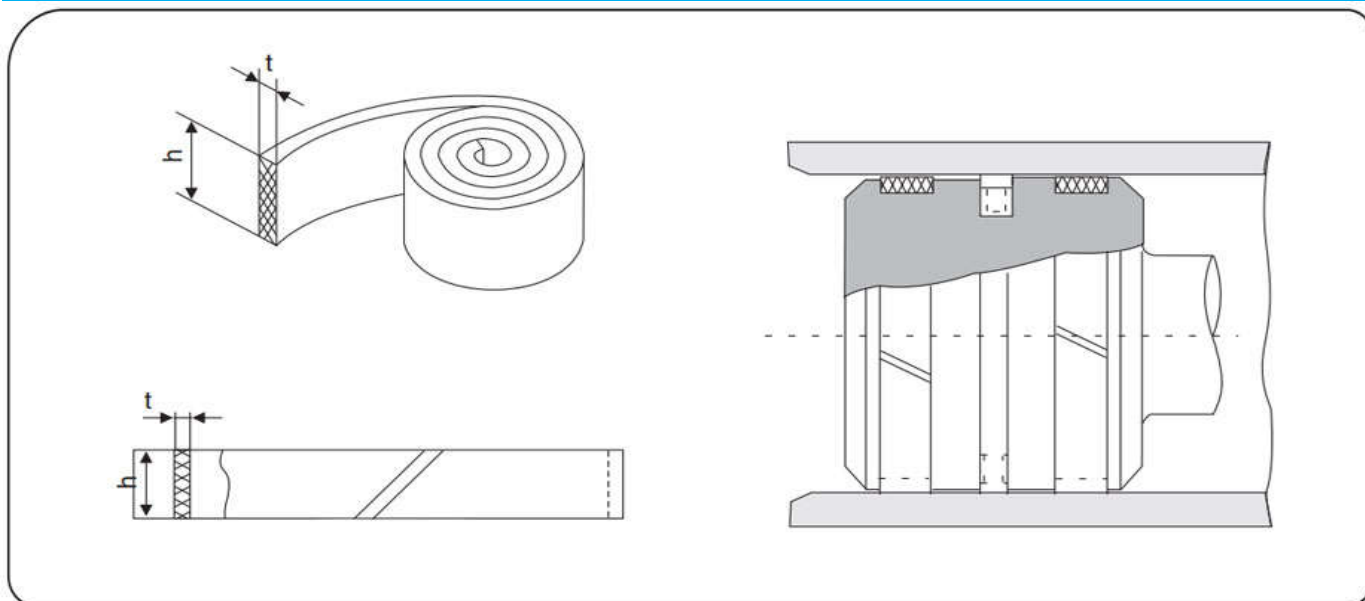

编号 Part No.	高度 øh	厚度 øt
RYR 9.7*2	9.7	2
RYR 15*2	15	2
RYR 20*2	20	2
RYR 25*2	25	2
RYR 30*2	30	2
RYR 5.6*2.5	5.6	2.5
RYR 6.3*2.5	6.3	2.5
RYR 8*2.5	8	2.5
RYR 9.7*2.5	9.7	2.5
RYR 13*2.5	13	2.5
RYR 15*2.5	15	2.5
RYR 20*2.5	20	2.5
RYR 25*2.5	25	2.5
RYR 30*2.5	30	2.5
RYR 9.7*3	9.7	3
RYR 13*3	13	3
RYR 15*3	15	3
RYR 20*3	20	3
RYR 25*3	25	3
RYR 30*3	30	3
RYR 40*3	40	3
RYR 9.7*4	9.7	4
RYR 15*4	15	4
RYR 20*4	20	4
RYR 25*4	25	4
RYR 30*4	30	4
RYR 40*4	40	4

编号 Part No.	高度 øh	厚度 øt



## 导向/耐磨环

## GUIDE RING WEAR RING

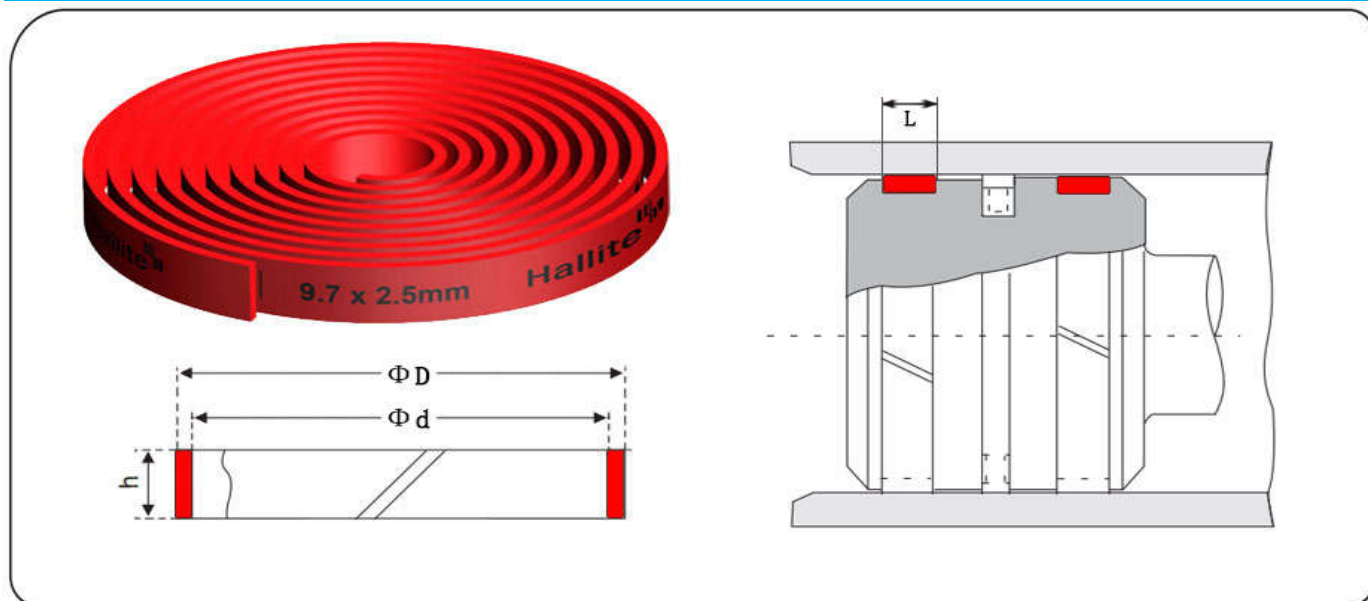

编号 Part No.	外径 øD	内径 ød	高度 h	槽宽 L
506 18*13*5.4	18	13	5.4	5.6
506 18*15*5.4	18	15	5.4	5.6
506 19*16*5.4	19	16	5.4	5.6
506 20*15*5.4	20	15	5.4	5.6
506 20*17*5.4	20	17	5.4	5.6
506 22*18*9.7	22	18	9.7	10
506 25*20*5.4	25	20	5.4	5.6
506 25*20*6	25	20	6	6.3
506 25*22*5.4	25	22	5.4	5.6
506 25.4*21.4*9.7	25.4	21.4	9.7	10
506 27*22*5.4	27	22	5.4	5.6
506 28*23*12.7	28	23	12.7	13
506 28*24*9.7	28	24	9.7	10
506 28*25*5.4	28	25	5.4	5.6
506 30*25*5.4	30	25	5.4	5.6
506 30*25*6	30	25	6	6.3
506 30*25*9.4	30	25	9.4	9.7
506 30*27*5.4	30	27	5.4	5.6
506 31.75*26.75*5.4	31.75	26.75	5.4	5.6
506 31.75*26.75*9.4	31.75	26.75	9.4	9.7
506 32*27*5.4	32	27	5.4	5.6
506 32*27*6	32	27	6	6.3
506 32*27*9.4	32	27	9.4	9.7
506 32*28*9.4	32	28	9.4	9.7
506 32*28*9.7	32	28	9.7	10
506 32*29*5.4	32	29	5.4	5.6
506 33*28*6	33	28	6	6.3
506 33*28*12.7	33	28	12.7	13
506 34*30*9.7	34	30	9.7	10
506 35*29*9.4	35	29	9.4	9.7

编号 Part No.	外径 øD	内径 ød	高度 h	槽宽 L
506 35*30*5.4	35	30	5.4	5.6
506 35*30*6	35	30	6	6.3
506 35*30*7.8	35	30	7.8	8
506 35*30*9.4	35	30	9.4	9.7
506 35*31*9.7	35	31	9.7	10
506 36*31*7.8	36	31	7.8	8
506 36*31*9.4	36	31	9.4	9.7
506 36*31*14.7	36	31	14.7	15
506 37*32*6	37	32	6	6.3
506 38*33*9.4	38	33	9.4	9.7
506 38.1*32.1*9.4	38.1	32.1	9.4	9.7
506 38.1*33.1*5.4	38.1	33.1	5.4	5.6
506 38.1*33.1*9.4	38.1	33.1	9.4	9.7
506 38.1*33.1*14.7	38.1	33.1	14.7	15
506 38.2*33.2*9.4	38.2	33.2	9.4	9.7
506 40*34*9.4	40	34	9.4	9.7
506 40*35*6	40	35	6	6.3
506 40*35*7.8	40	35	7.8	8
506 40*35*9.4	40	35	9.4	9.7
506 40*35*14.7	40	35	14.7	15
506 40*35*19.5	40	35	19.5	20
506 40*36*9.4	40	36	9.4	9.7
506 40*36*9.7	40	36	9.7	10
506 40*36*14.7	40	36	14.7	15
506 40*37*5.4	40	37	5.4	5.6
506 41*36*5.4	41	36	5.4	5.6
506 41*36*6	41	36	6	6.3
506 41*36*9.4	41	36	9.4	9.7
506 41*36*14.7	41	36	14.7	15
506 41*36*19.5	41	36	19.5	20

## 导向/耐磨环

### GUIDE RING WEAR RING

编号 Part No	外径 øD	内径 ød	高度 h	槽宽 I
506 44.45*39.45*5.4	44.45	39.45	5.4	5.6
506 44.45*39.45*9.4	44.45	39.45	9.4	9.7
506 44.5*39.5*9.4	44.5	39.5	9.4	9.7
506 45*40*5.4	45	40	5.4	5.6
506 45*40*7.8	45	40	7.8	8
506 45*40*9.4	45	40	9.4	9.7
506 45*40*12.7	45	40	12.7	13
506 45*40*14.7	45	40	14.7	15
506 45*40*19.5	45	40	19.5	20
506 45*41*9.7	45	41	9.7	10
506 45*42*5.4	45	42	5.4	5.6
506 46*41*5.4	46	41	5.4	5.6
506 46*41*9.4	46	41	9.4	9.7
506 46*41*19.5	46	41	19.5	20
506 50*43.65*12.5	50	43.65	12.5	12.7
506 50*44*9.4	50	44	9.4	9.7
506 50*45*5.4	50	45	5.4	5.6
506 50*45*6	50	45	6	6.3
506 50*45*6.8	50	45	6.8	7
506 50*45*7.8	50	45	7.8	8
506 50*45*9.4	50	45	9.4	9.7
506 50*45*12.7	50	45	12.7	13
506 50*45*14.7	50	45	14.7	15
506 50*45*24.5	50	45	24.5	25
506 50*46*9.4	50	46	9.4	9.7
506 50*46*9.7	50	46	9.7	10
506 50*46*14.7	50	46	14.7	15
506 50*47*5.4	50	47	5.4	5.6
506 50.8*45.8*5.4	50.8	45.8	5.4	5.6
506 50.8*45.8*9.4	50.8	45.8	9.4	9.7
506 50.8*45.8*14.7	50.8	45.8	14.7	15
506 50.8*46.8*9.7	50.8	46.8	9.7	10
506 50.8*46.8*19.5	50.8	46.8	19.5	20
506 50.9*45.9*9.4	50.9	45.9	9.4	9.7
506 51*45*19.2	51	45	19.2	19.5
506 51*46*5.4	51	46	5.4	5.6
506 52*47*9.4	52	47	9.4	9.7
506 53.8*48.8*5.4	53.8	48.8	5.4	5.6
506 54*48*12.5	54	48	12.5	12.8
506 54*49*5.4	54	49	5.4	5.6
506 55*49*12.5	55	49	12.5	12.8
506 55*50*5.4	55	50	5.4	5.6
506 55*50*6	55	50	6	6.3
506 55*50*9.4	55	50	9.4	9.7
506 55*50*12.7	55	50	12.7	13
506 55*50*14.7	55	50	14.7	15
506 55*50*19.5	55	50	19.5	20
506 55*51*9.4	55	51	9.4	9.7
506 55*51*9.7	55	51	9.7	10

编号 Part No	外径 øD	内径 ød	高度 h	槽宽 I
506 55*51*14.7	55	51	14.7	15
506 56*51*9.4	56	51	9.4	9.7
506 56*51*14.7	56	51	14.7	15
506 57.1*50.75*12.5	57.1	50.75	12.5	12.7
506 57.15*52.15*5.4	57.15	52.15	5.4	5.6
506 58*53*5.4	58	53	5.4	5.6
506 58*53*19.5	58	53	19.5	20
506 60*53.65*12.5	60	53.65	12.5	12.7
506 60*54*9.4	60	54	9.4	9.7
506 60*54*12.5	60	54	12.5	12.8
506 60*55*5.4	60	55	5.4	5.6
506 60*55*6	60	55	6	6.3
506 60*55*6.8	60	55	6.8	7
506 60*55*7.8	60	55	7.8	8
506 60*55*9.4	60	55	9.4	9.7
506 60*55*12.7	60	55	12.7	13
506 60*55*14.7	60	55	14.7	15
506 60*55*19.5	60	55	19.5	20
506 60*55*24.5	60	55	24.5	25
506 60*56*9.7	60	56	9.7	10
506 60.3*55.3*9.4	60.3	55.3	9.4	9.7
506 61*56*9.4	61	56	9.4	9.7
506 63*55*6	63	55	6	6.1
506 63*57*9.4	63	57	9.4	9.7
506 63*57*12.5	63	57	12.5	12.8
506 63*58*5.4	63	58	5.4	5.6
506 63*58*6	63	58	6	6.3
506 63*58*6.8	63	58	6.8	7
506 63*58*7.8	63	58	7.8	8
506 63*58*9.4	63	58	9.4	9.7
506 63*58*12.7	63	58	12.7	13
506 63*58*14.7	63	58	14.7	15
506 63*58*19.5	63	58	19.5	20
506 63*58*24.5	63	58	24.5	25
506 63*59*9.7	63	59	9.7	10
506 63*59*14.7	63	59	14.7	15
506 63*60*5.4	63	60	5.4	5.6
506 63.5*58.5*5.4	63.5	58.5	5.4	5.6
506 63.5*58.5*9.4	63.5	58.5	9.4	9.7
506 63.5*58.5*14.7	63.5	58.5	14.7	15
506 63.5*58.5*19.5	63.5	58.5	19.5	20
506 63.6*58.6*9.4	63.6	58.6	9.4	9.7
506 64*60*14.7	64	60	14.7	15
506 65*59*12.5	65	59	12.5	12.8
506 65*60*5.4	65	60	5.4	5.6
506 65*60*7.8	65	60	7.8	8
506 65*60*9.4	65	60	9.4	9.7
506 65*60*12.7	65	60	12.7	13
506 65*60*14.7	65	60	14.7	15

## 导向/耐磨环

### GUIDE RING WEAR RING

编号 Part No	外径 øD	内径 ød	高度 h	槽宽 I
506 65*60*19.5	65	60	19.5	20
506 65*60*24.5	65	60	24.5	25
506 65*61*9.4	65	61	9.4	9.7
506 65*61*9.7	65	61	9.7	10
506 66.5*61.5*24.5	66.5	61.5	24.5	25
506 66.67*61.67*5.4	66.67	61.67	5.4	5.6
506 66.68*60.33*12.5	66.68	60.33	12.5	12.7
506 67.07*62.07*9.4	67.07	62.07	9.4	9.7
506 68*63*9.4	68	63	9.4	9.7
506 69.85*65.85*24.5	69.85	65.85	24.5	25
506 70*63.3*25	70	63.3	25	25.4
506 70*63.65*12.5	70	63.65	12.5	12.7
506 70*63.65*25	70	63.65	25	25.4
506 70*64*12.5	70	64	12.5	12.8
506 70*64*24.5	70	64	24.5	25
506 70*65*5.4	70	65	5.4	5.6
506 70*65*6	70	65	6	6.3
506 70*65*6.8	70	65	6.8	7
506 70*65*7.8	70	65	7.8	8
506 70*65*9.4	70	65	9.4	9.7
506 70*65*12.7	70	65	12.7	13
506 70*65*14.7	70	65	14.7	15
506 70*65*19.5	70	65	19.5	20
506 70*66*9.4	70	66	9.4	9.7
506 70*66*9.7	70	66	9.7	10
506 70*66*19.5	70	66	19.5	20
506 70.5*65.5*9.4	70.5	65.5	9.4	9.7
506 71*66*5.4	71	66	5.4	5.6
506 71*66*19.5	71	66	19.5	20
506 72*67*9.4	72	67	9.4	9.7
506 72*67*19.5	72	67	19.5	20
506 73*68*9.4	73	68	9.4	9.7
506 75*69*9.4	75	69	9.4	9.7
506 75*69*12.5	75	69	12.5	12.8
506 75*69*19.5	75	69	19.5	20
506 75*70*5.4	75	70	5.4	5.6
506 75*70*9.4	75	70	9.4	9.7
506 75*70*12.7	75	70	12.7	13
506 75*70*14.7	75	70	14.7	15
506 75*70*19.5	75	70	19.5	20
506 75*70*24.5	75	70	24.5	25
506 75*71*9.4	75	71	9.4	9.7
506 75*71*9.7	75	71	9.7	10
506 75.85*69.5*12.5	75.85	69.5	12.5	12.7
506 75.85*70.85*5.4	75.85	70.85	5.4	5.6
506 76.2*70.2*12.5	76.2	70.2	12.5	12.8
506 76.2*70.2*19.5	76.2	70.2	19.5	20
506 76.2*71.2*5.4	76.2	71.2	5.4	5.6
506 76.2*71.2*9.4	76.2	71.2	9.4	9.7

编号 Part No	外径 øD	内径 ød	高度 h	槽宽 I
506 76.2*71.2*14.7	76.2	71.2	14.7	15
506 76.2*72.2*9.7	76.2	72.2	9.7	10
506 76.3*71.3*9.4	76.3	71.3	9.4	9.7
506 78*71.65*12.5	78	71.65	12.5	12.7
506 78*73*9.4	78	73	9.4	9.7
506 79.2*74.2*14.7	79.2	74.2	14.7	15
506 80*72*9.4	80	72	9.4	9.7
506 80*73.65*12.5	80	73.65	12.5	12.7
506 80*73.65*18.7	80	73.65	18.7	19.05
506 80*74*12.5	80	74	12.5	12.8
506 80*74*19.2	80	74	19.2	19.5
506 80*74*19.5	80	74	19.5	20
506 80*74*24.5	80	74	24.5	25
506 80*75*5.4	80	75	5.4	5.6
506 80*75*6	80	75	6	6.3
506 80*75*7.8	80	75	7.8	8
506 80*75*9.4	80	75	9.4	9.7
506 80*75*12.7	80	75	12.7	13
506 80*75*14.7	80	75	14.7	15
506 80*75*19.5	80	75	19.5	20
506 80*75*24.5	80	75	24.5	25
506 80*75*29.5	80	75	29.5	30
506 80*76*9.4	80	76	9.4	9.7
506 80*76*9.7	80	76	9.7	10
506 80*76*14.7	80	76	14.7	15
506 81*76*5.4	81	76	5.4	5.6
506 82*77*7.8	82	77	7.8	8
506 82*77*14.7	82	77	14.7	15
506 82.55*76.2*12.5	82.55	76.2	12.5	12.7
506 82.55*76.2*18.7	82.55	76.2	18.7	19.05
506 82.55*77.55*5.4	82.55	77.55	5.4	5.6
506 82.55*77.55*9.4	82.55	77.55	9.4	9.7
506 82.55*77.55*14.7	82.55	77.55	14.7	15
506 82.8*77.8*9.4	82.8	77.8	9.4	9.7
506 85*78.3*25	85	78.3	25	25.4
506 85*79*12.5	85	79	12.5	12.8
506 85*79*24.5	85	79	24.5	25
506 85*80*5.4	85	80	5.4	5.6
506 85*80*6	85	80	6	6.3
506 85*80*9.4	85	80	9.4	9.7
506 85*80*12.7	85	80	12.7	13
506 85*80*14.7	85	80	14.7	15
506 85*80*19.5	85	80	19.5	20
506 85*80*24.5	85	80	24.5	25
506 88*83*19.5	88	83	19.5	20
506 88.9*82.9*9.4	88.9	82.9	9.4	9.7
506 88.9*82.9*12.5	88.9	82.9	12.5	12.8
506 88.9*83.9*5.4	88.9	83.9	5.4	5.6
506 88.9*83.9*19.5	88.9	83.9	19.5	20

## 导向/耐磨环

### GUIDE RING WEAR RING

编号 Part No	外径 øD	内径 ød	高度 h	槽宽 I
506 88.9*84.9*19.5	88.9	84.9	19.5	20
506 90*82*24.5	90	82	24.5	25
506 90*83.3*25	90	83.3	25	25.4
506 90*83.65*12.5	90	83.65	12.5	12.7
506 90*83.65*18.7	90	83.65	18.7	19.05
506 90*83.65*25	90	83.65	25	25.4
506 90*84*12.5	90	84	12.5	12.8
506 90*84*24.5	90	84	24.5	25
506 90*85*5.4	90	85	5.4	5.6
506 90*85*6	90	85	6	6.3
506 90*85*7.8	90	85	7.8	8
506 90*85*9.4	90	85	9.4	9.7
506 90*85*12.7	90	85	12.7	13
506 90*85*14.7	90	85	14.7	15
506 90*85*19.5	90	85	19.5	20
506 90*85*24.5	90	85	24.5	25
506 90*85*29.5	90	85	29.5	30
506 90*86*9.7	90	86	9.7	10
506 90*86*14.7	90	86	14.7	15
506 90*86*24.5	90	86	24.5	25
506 92*87*9.4	92	87	9.4	9.7
506 92*87*12.7	92	87	12.7	13
506 92*87*14.7	92	87	14.7	15
506 94.45*89.45*9.4	94.45	89.45	9.4	9.7
506 95*88.3*12.5	95	88.3	12.5	12.7
506 95*89*12.5	95	89	12.5	12.8
506 95*89*19.2	95	89	19.2	19.5
506 95*90*6	95	90	6	6.3
506 95*90*9.4	95	90	9.4	9.7
506 95*90*12.7	95	90	12.7	13
506 95*90*14.7	95	90	14.7	15
506 95*90*19.5	95	90	19.5	20
506 95*90*24.5	95	90	24.5	25
506 95.25*90.25*5.4	95.25	90.25	5.4	5.6
506 95.25*91.25*9.7	95.25	91.25	9.7	10
506 95.25*91.25*24.5	95.25	91.25	24.5	25
506 96*91*19.5	96	91	19.5	20
506 98*93*24.5	98	93	24.5	25
506 98.05*91.7*12.5	98.05	91.7	12.5	12.7
506 98.05*93.05*5.4	98.05	93.05	5.4	5.6
506 100*92*24.5	100	92	24.5	25
506 100*93.65*12.5	100	93.65	12.5	12.7
506 100*93.65*15.5	100	93.65	15.5	15.88
506 100*93.65*18.7	100	93.65	18.7	19.05
506 100*93.65*25	100	93.65	25	25.4
506 100*93.96*14.7	100	93.96	14.7	15
506 100*94*9.4	100	94	9.4	9.7
506 100*94*12.5	100	94	12.5	12.8
506 100*94*19.5	100	94	19.5	20

编号 Part No	外径 øD	内径 ød	高度 h	槽宽 I
506 100*94*24.5	100	94	24.5	25
506 100*95*5.4	100	95	5.4	5.6
506 100*95*6	100	95	6	6.3
506 100*95*7.8	100	95	7.8	8
506 100*95*9.4	100	95	9.4	9.7
506 100*95*12.7	100	95	12.7	13
506 100*95*14.7	100	95	14.7	15
506 100*95*19.5	100	95	19.5	20
506 100*95*24.5	100	95	24.5	25
506 100*95*29.5	100	95	29.5	30
506 100*95*39.5	100	95	39.5	40
506 100*96*9.4	100	96	9.4	9.7
506 100*96*9.7	100	96	9.7	10
506 100*96*14.7	100	96	14.7	15
506 101.6*96.6*5.4	101.6	96.6	5.4	5.6
506 101.6*96.6*9.4	101.6	96.6	9.4	9.7
506 101.6*96.6*14.7	101.6	96.6	14.7	15
506 104*99*19.5	104	99	19.5	20
506 104*100*14.7	104	100	14.7	15
506 105*97*19.5	105	97	19.5	20
506 105*97*24.5	105	97	24.5	25
506 105*98.3*12.5	105	98.3	12.5	12.7
506 105*98.65*12.5	105	98.65	12.5	12.7
506 105*98.96*14.7	105	98.96	14.7	15
506 105*99*12.5	105	99	12.5	12.8
506 105*100*5.4	105	100	5.4	5.6
506 105*100*6	105	100	6	6.3
506 105*100*9.4	105	100	9.4	9.7
506 105*100*14.7	105	100	14.7	15
506 105*100*19.5	105	100	19.5	20
506 105*100*24.5	105	100	24.5	25
506 105*101*14.7	105	101	14.7	15
506 106*100*19.5	106	100	19.5	20
506 106*101*19.5	106	101	19.5	20
506 106*101*24.5	106	101	24.5	25
506 107.95*102.95*5.4	108	103	5.4	5.6
506 108*102*12.5	108	102	12.5	12.8
506 108*103*9.4	108	103	9.4	9.7
506 108*103*14.7	108	103	14.7	15
506 109*104*19.5	109	104	19.5	20
506 110*102*9.4	110	102	9.4	9.7
506 110*102*29.5	110	102	29.5	30
506 110*103.3*9.4	110	103.3	9.4	9.7
506 110*103.3*12.5	110	103.3	12.5	12.7
506 110*103.65*12.5	110	103.7	12.5	12.7
506 110*103.65*18.7	110	103.7	18.7	19.05
506 110*104*12.5	110	104	12.5	12.8
506 110*104*24.5	110	104	24.5	25
506 110*105*7.8	110	105	7.8	8

## 导向/耐磨环

### GUIDE RING WEAR RING

编号 Part No	外径 øD	内径 ød	高度 h	槽宽 I
506 110*105*9.4	110	105	9.4	9.7
506 110*105*12.7	110	105	12.7	13
506 110*105*14.7	110	105	14.7	15
506 110*105*19.5	110	105	19.5	20
506 110*105*24.5	110	105	24.5	25
506 110*105*29.5	110	105	29.5	30
506 110*106*9.7	110	106	9.7	10
506 110*106*19.5	110	106	19.5	20
506 110*106*24.5	110	106	24.5	25
506 111*105*19.5	111	105	19.5	20
506 111*106*9.4	111	106	9.4	9.7
506 114*109*14.7	114	109	14.7	15
506 114.3*107.95*25	114.3	108	25	25.4
506 114.3*109.3*5.4	114.3	109.3	5.4	5.6
506 114.3*109.3*12.7	114.3	109.3	12.7	13
506 115*107*24.5	115	107	24.5	25
506 115*107*29.5	115	107	29.5	30
506 115*108.65*12.5	115	108.7	12.5	12.7
506 115*109*24.5	115	109	24.5	25
506 115*110*5.4	115	110	5.4	5.6
506 115*110*6	115	110	6	6.3
506 115*110*7.8	115	110	7.8	8
506 115*110*9.4	115	110	9.4	9.7
506 115*110*14.7	115	110	14.7	15
506 115*110*19.5	115	110	19.5	20
506 115*110*24.5	115	110	24.5	25
506 115*110*29.5	115	110	29.5	30
506 115*111*9.7	115	111	9.7	10
506 116*111*19.5	116	111	19.5	20
506 118.9*113.9*24.5	118.9	113.9	24.5	25
506 120*112*19.5	120	112	19.5	20
506 120*113.96*14.7	120	114	14.7	15
506 120*114*9.4	120	114	9.4	9.7
506 120*114*12.5	120	114	12.5	12.8
506 120*114*29.5	120	114	29.5	30
506 120*115*5.4	120	115	5.4	5.6
506 120*115*6	120	115	6	6.3
506 120*115*7.8	120	115	7.8	8
506 120*115*9.4	120	115	9.4	9.7
506 120*115*12.7	120	115	12.7	13
506 120*115*14.7	120	115	14.7	15
506 120*115*19.5	120	115	19.5	20
506 120*115*24.5	120	115	24.5	25
506 120*115*29.5	120	115	29.5	30
506 120*116*9.7	120	116	9.7	10
506 120.3*113.95*12.5	120.3	114	12.5	12.7
506 120.3*115.3*5.4	120.3	115.3	5.4	5.6
506 120.65*115.65*5.4	120.7	115.7	5.4	5.6
506 120.65*115.65*9.4	120.7	115.7	9.4	9.7

编号 Part No	外径 øD	内径 ød	高度 h	槽宽 I
506 120.65*116.65*19.5	120.7	116.7	19.5	20
506 122*117*14.7	122	117	14.7	15
506 125*117*24.5	125	117	24.5	25
506 125*117*39.5	125	117	39.5	40
506 125*118.65*12.5	125	118.7	12.5	12.7
506 125*118.65*15.5	125	118.7	15.5	15.88
506 125*118.65*18.7	125	118.7	18.7	19.05
506 125*118.65*25	125	118.7	25	25.4
506 125*118.96*14.7	125	119	14.7	15
506 125*119*9.4	125	119	9.4	9.7
506 125*119*12.5	125	119	12.5	12.8
506 125*119*19.2	125	119	19.2	19.5
506 125*119*24.5	125	119	24.5	25
506 125*119*29.5	125	119	29.5	30
506 125*120*5.4	125	120	5.4	5.6
506 125*120*7.8	125	120	7.8	8
506 125*120*9.4	125	120	9.4	9.7
506 125*120*12.7	125	120	12.7	13
506 125*120*14.7	125	120	14.7	15
506 125*120*15.5	125	120	15.5	16
506 125*120*19.5	125	120	19.5	20
506 125*120*24.5	125	120	24.5	25
506 125*120*29.5	125	120	29.5	30
506 125*120*39.5	125	120	39.5	40
506 125*121*14.7	125	121	14.7	15
506 125*121*19.5	125	121	19.5	20
506 125*121*21.5	125	121	21.5	22
506 126*121*19.5	126	121	19.5	20
506 127*122*5.4	127	122	5.4	5.6
506 127*122*14.7	127	122	14.7	15
506 127*122*19.5	127	122	19.5	20
506 127*122*24.5	127	122	24.5	25
506 127*123*9.7	127	123	9.7	10
506 127*123*24.5	127	123	24.5	25
506 130*123.65*12.5	130	123.7	12.5	12.7
506 130*123.65*15.5	130	123.7	15.5	15.88
506 130*123.65*18.7	130	123.7	18.7	19.05
506 130*123.65*25	130	123.7	25	25.4
506 130*123.96*14.7	130	124	14.7	15
506 130*124*12.5	130	124	12.5	12.8
506 130*124*19.5	130	124	19.5	20
506 130*125*5.4	130	125	5.4	5.6
506 130*125*7.8	130	125	7.8	8
506 130*125*9.4	130	125	9.4	9.7
506 130*125*12.7	130	125	12.7	13
506 130*125*14.7	130	125	14.7	15
506 130*125*19.5	130	125	19.5	20
506 130*125*24.5	130	125	24.5	25
506 130*126*14.7	130	126	14.7	15

## 导向/耐磨环

### GUIDE RING WEAR RING

编号 Part No	外径 øD	内径 ød	高度 h	槽宽 I
506 131*125*19.5	131	125	19.5	20
506 131*126*19.5	131	126	19.5	20
506 132*127*14.7	132	127	14.7	15
506 133*127*12.5	133	127	12.5	12.8
506 133*128*14.7	133	128	14.7	15
506 133.35*128.35*9.4	133.4	128.4	9.4	9.7
506 135*128*24.5	135	128	24.5	25
506 135*130*7.8	135	130	7.8	8
506 135*130*9.4	135	130	9.4	9.7
506 135*130*12.7	135	130	12.7	13
506 135*130*14.7	135	130	14.7	15
506 135*130*19.5	135	130	19.5	20
506 135*130*24.5	135	130	24.5	25
506 135*130*29.5	135	130	29.5	30
506 136*131*5.4	136	131	5.4	5.6
506 137*132*24.5	137	132	24.5	25
506 138*133*19.5	138	133	19.5	20
506 139*134*5.4	139	134	5.4	5.6
506 139.5*134.5*14.7	139.5	134.5	14.7	15
506 140*132*19.5	140	132	19.5	20
506 140*132*24.5	140	132	24.5	25
506 140*132*39.5	140	132	39.5	40
506 140*134*12.5	140	134	12.5	12.8
506 140*134*19.5	140	134	19.5	20
506 140*134*29.5	140	134	29.5	30
506 140*135*5.4	140	135	5.4	5.6
506 140*135*9.4	140	135	9.4	9.7
506 140*135*12.7	140	135	12.7	13
506 140*135*14.7	140	135	14.7	15
506 140*135*15.5	140	135	15.5	16
506 140*135*19.5	140	135	19.5	20
506 140*135*24.5	140	135	24.5	25
506 140*135*29.5	140	135	29.5	30
506 140*136*14.7	140	136	14.7	15
506 141*136*19.5	141	136	19.5	20
506 145*138.65*15.5	145	138.7	15.5	15.88
506 145*139*12.5	145	139	12.5	12.8
506 145*140*9.4	145	140	9.4	9.7
506 145*140*14.7	145	140	14.7	15
506 145*140*19.5	145	140	19.5	20
506 145*140*24.5	145	140	24.5	25
506 146*140*19.5	146	140	19.5	20
506 146.05*139.7*12.5	146.1	139.7	12.5	12.7
506 146.05*140.05*19.5	146.1	140.1	19.5	20
506 146.05*141.05*5.4	146.1	141.1	5.4	5.6
506 147*142*24.5	147	142	24.5	25
506 148*140*24.5	148	140	24.5	25
506 150*142*19.5	150	142	19.5	20
506 150*142*24.5	150	142	24.5	25

编号 Part No	外径 øD	内径 ød	高度 h	槽宽 I
506 150*143.65*15.5	150	143.7	15.5	15.88
506 150*143.65*25	150	143.7	25	25.4
506 150*144*12.5	150	144	12.5	12.8
506 150*144*24.5	150	144	24.5	25
506 150*145*5.4	150	145	5.4	5.6
506 150*145*9.4	150	145	9.4	9.7
506 150*145*12.7	150	145	12.7	13
506 150*145*14.7	150	145	14.7	15
506 150*145*15.5	150	145	15.5	16
506 150*145*19.5	150	145	19.5	20
506 150*145*24.5	150	145	24.5	25
506 150*146*9.7	150	146	9.7	10
506 151*146*19.5	151	146	19.5	20
506 152*147*14.7	152	147	14.7	15
506 152.4*147.4*5.4	152.4	147.4	5.4	5.6
506 152.4*147.4*14.7	152.4	147.4	14.7	15
506 152.4*147.4*19.5	152.4	147.4	19.5	20
506 155*147*14.7	155	147	14.7	15
506 155*150*14.7	155	150	14.7	15
506 155*150*24.5	155	150	24.5	25
506 155*150*29.5	155	150	29.5	30
506 155.5*150.5*19.5	155.5	150.5	19.5	20
506 156*150*19.5	156	150	19.5	20
506 156*151*19.5	156	151	19.5	20
506 160*152*14.7	160	152	14.7	15
506 160*152*19.5	160	152	19.5	20
506 160*152*29.5	160	152	29.5	30
506 160*153*24.5	160	153	24.5	25
506 160*153.65*12.5	160	153.7	12.5	12.7
506 160*153.65*15.5	160	153.7	15.5	15.88
506 160*153.65*18.7	160	153.7	18.7	19.05
506 160*153.65*25	160	153.7	25	25.4
506 160*153.96*14.7	160	154	14.7	15
506 160*154*9.4	160	154	9.4	9.7
506 160*154*12.5	160	154	12.5	12.8
506 160*154*14.7	160	154	14.7	15
506 160*154*19.2	160	154	19.2	19.5
506 160*154*19.5	160	154	19.5	20
506 160*154*29.5	160	154	29.5	30
506 160*155*5.4	160	155	5.4	5.6
506 160*155*7.8	160	155	7.8	8
506 160*155*9.4	160	155	9.4	9.7
506 160*155*12.7	160	155	12.7	13
506 160*155*14.7	160	155	14.7	15
506 160*155*19.5	160	155	19.5	20
506 160*155*24.5	160	155	24.5	25
506 160*155*29.5	160	155	29.5	30
506 160*156*14.7	160	156	14.7	15
506 161*156*14.7	161	156	14.7	15



## 导向/耐磨环

### GUIDE RING WEAR RING

编号 Part No	外径 øD	内径 ød	高度 h	槽宽 I
506 161*156*19.5	161	156	19.5	20
506 162*157*5.4	162	157	5.4	5.6
506 162*157*14.7	162	157	14.7	15
506 162*157*19.5	162	157	19.5	20
506 163*158*14.7	163	158	14.7	15
506 164.8*159.8*14.7	164.8	159.8	14.7	15
506 165*157*24.5	165	157	24.5	25
506 165*159*19.5	165	159	19.5	20
506 165*159*24.5	165	159	24.5	25
506 165*160*9.4	165	160	9.4	9.7
506 165*160*14.7	165	160	14.7	15
506 165*160*19.5	165	160	19.5	20
506 165*160*24.5	165	160	24.5	25
506 165.1*161.1*9.7	165.1	161.1	9.7	10
506 166*161*19.5	166	161	19.5	20
506 167*162*14.7	167	162	14.7	15
506 167.4*162.4*9.4	167.4	162.4	9.4	9.7
506 170*162*9.4	170	162	9.4	9.7
506 170*163.65*12.5	170	163.7	12.5	12.7
506 170*163.65*18.7	170	163.7	18.7	19.05
506 170*163.65*25	170	163.7	25	25.4
506 170*164*19.2	170	164	19.2	19.5
506 170*165*5.4	170	165	5.4	5.6
506 170*165*9.4	170	165	9.4	9.7
506 170*165*12.7	170	165	12.7	13
506 170*165*14.7	170	165	14.7	15
506 170*165*19.5	170	165	19.5	20
506 170*165*24.5	170	165	24.5	25
506 170*165*29.5	170	165	29.5	30
506 171.45*165.1*12.5	171.5	165.1	12.5	12.7
506 171.45*166.45*5.4	171.5	166.5	5.4	5.6
506 172*167*24.5	172	167	24.5	25
506 175*169*19.5	175	169	19.5	20
506 175*170*9.4	175	170	9.4	9.7
506 175*170*12.7	175	170	12.7	13
506 175*170*14.7	175	170	14.7	15
506 175*170*19.5	175	170	19.5	20
506 175*170*24.5	175	170	24.5	25
506 175*170*29.5	175	170	29.5	30
506 176*171*19.5	176	171	19.5	20
506 177.8*172.8*12.7	177.8	172.8	12.7	13
506 177.8*172.8*19.5	177.8	172.8	19.5	20
506 178*173*14.7	178	173	14.7	15
506 180*172*19.5	180	172	19.5	20
506 180*172*24.5	180	172	24.5	25
506 180*173*24.5	180	173	24.5	25
506 180*173.65*18.7	180	173.7	18.7	19.05
506 180*173.65*25	180	173.7	25	25.4
506 180*174*12.5	180	174	12.5	12.8

编号 Part No	外径 øD	内径 ød	高度 h	槽宽 I
506 180*174*19.5	180	174	19.5	20
506 180*174*29.5	180	174	29.5	30
506 180*174*39.5	180	174	39.5	40
506 180*175*7.8	180	175	7.8	8
506 180*175*9.4	180	175	9.4	9.7
506 180*175*14.7	180	175	14.7	15
506 180*175*19.5	180	175	19.5	20
506 180*175*24.5	180	175	24.5	25
506 180*175*29.5	180	175	29.5	30
506 180*175*39.5	180	175	39.5	40
506 180*176*9.7	180	176	9.7	10
506 180.5*174.5*19.5	180.5	174.5	19.5	20
506 184*179*12.7	184	179	12.7	13
506 184*179*14.7	184	179	14.7	15
506 184.2*179.2*5.4	184.2	179.2	5.4	5.6
506 186*180*19.5	186	180	19.5	20
506 186*181*19.5	186	181	19.5	20
506 190*182*14.7	190	182	14.7	15
506 190*182*24.5	190	182	24.5	25
506 190*183.65*12.5	190	183.7	12.5	12.7
506 190*184*9.4	190	184	9.4	9.7
506 190*185*5.4	190	185	5.4	5.6
506 190*185*9.4	190	185	9.4	9.7
506 190*185*14.7	190	185	14.7	15
506 190*185*19.5	190	185	19.5	20
506 190*185*24.5	190	185	24.5	25
506 190*185*29.5	190	185	29.5	30
506 190.5*184.5*19.5	190.5	184.5	19.5	20
506 191*186*19.5	191	186	19.5	20
506 192*187*24.5	192	187	24.5	25
506 194.5*188.5*19.5	194.5	188.5	19.5	20
506 195*188.65*12.5	195	188.7	12.5	12.7
506 195*188.65*18.7	195	188.7	18.7	19.05
506 195*190*5.4	195	190	5.4	5.6
506 195*190*9.4	195	190	9.4	9.7
506 195*190*19.5	195	190	19.5	20
506 195*190*24.5	195	190	24.5	25
506 196.85*190.5*12.5	196.9	190.5	12.5	12.7
506 196.85*190.85*19.5	196.9	190.9	19.5	20
506 196.85*191.85*5.4	196.9	191.9	5.4	5.6
506 198*190*24.5	198	190	24.5	25
506 200*192*14.7	200	192	14.7	15
506 200*192*19.5	200	192	19.5	20
506 200*192*24.5	200	192	24.5	25
506 200*192*29.5	200	192	29.5	30
506 200*192*39.5	200	192	39.5	40
506 200*193.65*12.5	200	193.7	12.5	12.7
506 200*193.65*15.5	200	193.7	15.5	15.88
506 200*193.65*18.7	200	193.7	18.7	19.05

## 导向/耐磨环

### GUIDE RING WEAR RING

编号 Part No	外径 øD	内径 ød	高度 h	槽宽 I
506 200*193.65*25	200	193.7	25	25.4
506 200*194*19.5	200	194	19.5	20
506 200*194*29.5	200	194	29.5	30
506 200*195*5.4	200	195	5.4	5.6
506 200*195*9.4	200	195	9.4	9.7
506 200*195*12.7	200	195	12.7	13
506 200*195*14.7	200	195	14.7	15
506 200*195*19.5	200	195	19.5	20
506 200*195*24.5	200	195	24.5	25
506 200*195*29.5	200	195	29.5	30
506 200*195*34.5	200	195	34.5	35
506 200*195*39.5	200	195	39.5	40
506 200.6*195.6*14.7	200.6	195.6	14.7	15
506 201*195*19.5	201	195	19.5	20
506 201*196*19.5	201	196	19.5	20
506 202*197*14.7	202	197	14.7	15
506 203*198*19.5	203	198	19.5	20
506 203.2*198.2*14.7	203.2	198.2	14.7	15
506 203.2*198.2*24.5	203.2	198.2	24.5	25
506 205*200*14.7	205	200	14.7	15
506 208*203*19.5	208	203	19.5	20
506 210*202*29.5	210	202	29.5	30
506 210*205*9.4	210	205	9.4	9.7
506 210*205*14.7	210	205	14.7	15
506 210*205*19.5	210	205	19.5	20
506 210*205*24.5	210	205	24.5	25
506 210*205*29.5	210	205	29.5	30
506 215*208.65*12.5	215	208.7	12.5	12.7
506 215*208.65*18.7	215	208.7	18.7	19.05
506 215*208.65*25	215	208.7	25	25.4
506 215*209*24.5	215	209	24.5	25
506 215*210*14.7	215	210	14.7	15
506 215*210*19.5	215	210	19.5	20
506 215*210*24.5	215	210	24.5	25
506 216*211*19.5	216	211	19.5	20
506 217*210.65*25	217	210.7	25	25.4
506 220*212*14.7	220	212	14.7	15
506 220*212*24.5	220	212	24.5	25
506 220*213.65*25	220	213.7	25	25.4
506 220*214*12.5	220	214	12.5	12.8
506 220*214*19.5	220	214	19.5	20
506 220*215*9.4	220	215	9.4	9.7
506 220*215*14.7	220	215	14.7	15
506 220*215*19.5	220	215	19.5	20
506 220*215*24.5	220	215	24.5	25
506 220*215*29.5	220	215	29.5	30
506 220*215*39.5	220	215	39.5	40
506 220*216*9.7	220	216	9.7	10
506 221*216*19.5	221	216	19.5	20

编号 Part No	外径 øD	内径 ød	高度 h	槽宽 I
506 221*216*29.5	221	216	29.5	30
506 222*217*19.5	222	217	19.5	20
506 222*217*29.5	222	217	29.5	30
506 222.25*215.9*12.5	222.3	215.9	12.5	12.7
506 222.25*217.25*5.4	222.3	217.3	5.4	5.6
506 224*219*29.5	224	219	29.5	30
506 225*217*19.5	225	217	19.5	20
506 225*218.65*25	225	218.7	25	25.4
506 225*220*9.4	225	220	9.4	9.7
506 225*220*12.7	225	220	12.7	13
506 225*220*14.7	225	220	14.7	15
506 225*220*19.5	225	220	19.5	20
506 225*220*24.5	225	220	24.5	25
506 225*220*29.5	225	220	29.5	30
506 228.6*220.6*24.5	228.6	220.6	24.5	25
506 230*222*14.7	230	222	14.7	15
506 230*222*24.5	230	222	24.5	25
506 230*222*39.5	230	222	39.5	40
506 230*223.65*25	230	223.7	25	25.4
506 230*225*9.4	230	225	9.4	9.7
506 230*225*14.7	230	225	14.7	15
506 230*225*19.5	230	225	19.5	20
506 230*225*24.5	230	225	24.5	25
506 230*225*29.5	230	225	29.5	30
506 230*225*39.5	230	225	39.5	40
506 235*227*9.4	235	227	9.4	9.7
506 235*230*12.7	235	230	12.7	13
506 235*230*14.7	235	230	14.7	15
506 235*230*19.5	235	230	19.5	20
506 235*230*24.5	235	230	24.5	25
506 235*230*29.5	235	230	29.5	30
506 240*232*24.5	240	232	24.5	25
506 240*232*29.5	240	232	29.5	30
506 240*232*39.5	240	232	39.5	40
506 240*233.65*18.7	240	233.7	18.7	19.05
506 240*233.65*25	240	233.7	25	25.4
506 240*235*9.4	240	235	9.4	9.7
506 240*235*14.7	240	235	14.7	15
506 240*235*19.5	240	235	19.5	20
506 240*235*24.5	240	235	24.5	25
506 240*235*29.5	240	235	29.5	30
506 240*235*39.5	240	235	39.5	40
506 245*237*24.5	245	237	24.5	25
506 245*240*9.4	245	240	9.4	9.7
506 245*240*14.7	245	240	14.7	15
506 245*240*29.5	245	240	29.5	30
506 250*242*9.4	250	242	9.4	9.7
506 250*242*14.7	250	242	14.7	15
506 250*242*19.5	250	242	19.5	20

## 导向/耐磨环

### GUIDE RING WEAR RING

编号 Part No	外径 øD	内径 ød	高度 h	槽宽 I
506 250*242*24.5	250	242	24.5	25
506 250*242*29.5	250	242	29.5	30
506 250*242*39.5	250	242	39.5	40
506 250*243.65*15.5	250	243.7	15.5	15.88
506 250*243.65*25	250	243.7	25	25.4
506 250*244*39.5	250	244	39.5	40
506 250*245*9.4	250	245	9.4	9.7
506 250*245*14.7	250	245	14.7	15
506 250*245*19.5	250	245	19.5	20
506 250*245*24.5	250	245	24.5	25
506 250*245*29.5	250	245	29.5	30
506 250*245*39.5	250	245	39.5	40
506 250*246*19.5	250	246	19.5	20
506 250.8*245.8*12.7	250.8	245.8	12.7	13
506 254*249*19.5	254	249	19.5	20
506 255*247*24.5	255	247	24.5	25
506 255*248.65*25	255	248.7	25	25.4
506 258*250*39.5	258	250	39.5	40
506 260*252*19.5	260	252	19.5	20
506 260*252*24.5	260	252	24.5	25
506 260*253.65*12.5	260	253.7	12.5	12.7
506 260*253.65*25	260	253.7	25	25.4
506 260*255*9.4	260	255	9.4	9.7
506 260*255*12.7	260	255	12.7	13
506 260*255*14.7	260	255	14.7	15
506 260*255*19.5	260	255	19.5	20
506 260*255*24.5	260	255	24.5	25
506 260*255*29.5	260	255	29.5	30
506 265*260*29.5	265	260	29.5	30
506 270*262*24.5	270	262	24.5	25
506 270*262*29.5	270	262	29.5	30
506 270*262*39.5	270	262	39.5	40
506 270*263.65*25	270	263.7	25	25.4
506 270*265*14.7	270	265	14.7	15
506 270*265*19.5	270	265	19.5	20
506 270*265*24.5	270	265	24.5	25
506 270*265*29.5	270	265	29.5	30
506 275*267*39.5	275	267	39.5	40
506 275*270*9.4	275	270	9.4	9.7
506 275*270*14.7	275	270	14.7	15
506 275*270*19.5	275	270	19.5	20
506 275*270*24.5	275	270	24.5	25
506 275*270*39.5	275	270	39.5	40
506 276*271*29.5	276	271	29.5	30
506 280*272*14.7	280	272	14.7	15
506 280*272*24.5	280	272	24.5	25
506 280*272*39.5	280	272	39.5	40
506 280*274*12.5	280	274	12.5	12.8
506 280*275*9.4	280	275	9.4	9.7

编号 Part No	外径 øD	内径 ød	高度 h	槽宽 I
506 280*275*14.7	280	275	14.7	15
506 280*275*19.5	280	275	19.5	20
506 280*275*24.5	280	275	24.5	25
506 280*275*29.5	280	275	29.5	30
506 280.5*275.5*24.5	280.5	275.5	24.5	25
506 281*276*24.5	281	276	24.5	25
506 285*277*29.5	285	277	29.5	30
506 285*278.65*25	285	278.7	25	25.4
506 285*280*14.7	285	280	14.7	15
506 285*280*24.5	285	280	24.5	25
506 285*280*29.5	285	280	29.5	30
506 290*282*14.7	290	282	14.7	15
506 290*282*24.5	290	282	24.5	25
506 290*282*29.5	290	282	29.5	30
506 290*282*39.5	290	282	39.5	40
506 290*283.65*25	290	283.7	25	25.4
506 290*284*24.5	290	284	24.5	25
506 290*285*9.4	290	285	9.4	9.7
506 290*285*14.7	290	285	14.7	15
506 290*285*19.5	290	285	19.5	20
506 290*285*24.5	290	285	24.5	25
506 290*285*29.5	290	285	29.5	30
506 295*288.65*25	295	288.7	25	25.4
506 295*290*29.5	295	290	29.5	30
506 300*292*14.7	300	292	14.7	15
506 300*292*19.5	300	292	19.5	20
506 300*292*24.5	300	292	24.5	25
506 300*292*29.5	300	292	29.5	30
506 300*292*39.5	300	292	39.5	40
506 300*293.65*25	300	293.7	25	25.4
506 300*294*12.5	300	294	12.5	12.8
506 300*294*19.5	300	294	19.5	20
506 300*294*29.5	300	294	29.5	30
506 300*294*39.5	300	294	39.5	40
506 300*295*5.4	300	295	5.4	5.6
506 300*295*14.7	300	295	14.7	15
506 300*295*19.5	300	295	19.5	20
506 300*295*24.5	300	295	24.5	25
506 300*295*29.5	300	295	29.5	30
506 301*293*24.5	301	293	24.5	25
506 304.8*299.8*19.5	304.8	299.8	19.5	20
506 305*300*9.4	305	300	9.4	9.7
506 305*300*14.7	305	300	14.7	15
506 305*300*24.5	305	300	24.5	25
506 305*300*29.5	305	300	29.5	30
506 310*305*24.5	310	305	24.5	25
506 310*305*29.5	310	305	29.5	30
506 315*310*14.7	315	310	14.7	15
506 320*312*24.5	320	312	24.5	25

## 导向/耐磨环

### GUIDE RING WEAR RING

编号 Part No	外径 øD	内径 ød	高度 h	槽宽 I
506 320*312*29.5	320	312	29.5	30
506 320*312*39.5	320	312	39.5	40
506 320*313*24.5	320	313	24.5	25
506 320*313.65*25	320	313.7	25	25.4
506 320*314*12.5	320	314	12.5	12.8
506 320*314*24.5	320	314	24.5	25
506 320*315*14.7	320	315	14.7	15
506 320*315*19.5	320	315	19.5	20
506 320*315*24.5	320	315	24.5	25
506 320*315*29.5	320	315	29.5	30
506 320*315*39.5	320	315	39.5	40
506 320*316*9.7	320	316	9.7	10
506 322*315.65*25	322	315.7	25	25.4
506 325*317*24.5	325	317	24.5	25
506 330*325*14.7	330	325	14.7	15
506 330*325*19.5	330	325	19.5	20
506 330*325*24.5	330	325	24.5	25
506 330*325*29.5	330	325	29.5	30
506 330*325*39.5	330	325	39.5	40
506 338*330*24.5	338	330	24.5	25
506 340*332*24.5	340	332	24.5	25
506 340*335*19.5	340	335	19.5	20
506 340*335*24.5	340	335	24.5	25
506 345*337*29.5	345	337	29.5	30
506 345*340*24.5	345	340	24.5	25
506 345*340*29.5	345	340	29.5	30
506 350*342*24.5	350	342	24.5	25
506 350*342*39.5	350	342	39.5	40
506 350*343.65*25	350	343.7	25	25.4
506 350*345*14.7	350	345	14.7	15
506 350*345*19.5	350	345	19.5	20
506 350*345*24.5	350	345	24.5	25
506 350*345*29.5	350	345	29.5	30
506 355*347*24.5	355	347	24.5	25
506 355*347*39.5	355	347	39.5	40
506 355*350*24.5	355	350	24.5	25
506 355.6*350.6*24.5	355.6	350.6	24.5	25
506 360*352*9.4	360	352	9.4	9.7
506 360*352*24.5	360	352	24.5	25
506 360*352*29.5	360	352	29.5	30
506 360*352*39.5	360	352	39.5	40
506 360*355*14.7	360	355	14.7	15
506 360*355*19.5	360	355	19.5	20
506 360*355*24.5	360	355	24.5	25
506 360*355*29.5	360	355	29.5	30
506 360*355*39.5	360	355	39.5	40
506 365*360*14.7	365	360	14.7	15
506 365*360*24.5	365	360	24.5	25
506 365*360*29.5	365	360	29.5	30

编号 Part No	外径 øD	内径 ød	高度 h	槽宽 I
506 370*362*29.5	370	362	29.5	30
506 370*363.65*12.5	370	363.7	12.5	12.7
506 370*363.65*25	370	363.7	25	25.4
506 370*365*14.7	370	365	14.7	15
506 370*365*19.5	370	365	19.5	20
506 370*365*24.5	370	365	24.5	25
506 370*365*29.5	370	365	29.5	30
506 380*372*24.5	380	372	24.5	25
506 380*372*29.5	380	372	29.5	30
506 380*375*14.7	380	375	14.7	15
506 380*375*19.5	380	375	19.5	20
506 380*375*24.5	380	375	24.5	25
506 380*375*29.5	380	375	29.5	30
506 390*382*39.5	390	382	39.5	40
506 390*385*19.5	390	385	19.5	20
506 390*385*24.5	390	385	24.5	25
506 400*392*24.5	400	392	24.5	25
506 400*393.65*25	400	393.7	25	25.4
506 400*395*14.7	400	395	14.7	15
506 400*395*19.5	400	395	19.5	20
506 400*395*24.5	400	395	24.5	25
506 400*395*29.5	400	395	29.5	30
506 402.5*394.5*24.5	402.5	394.5	24.5	25
506 402.5*397.5*29.5	402.5	397.5	29.5	30
506 410*402*24.5	410	402	24.5	25
506 410*404*24.5	410	404	24.5	25
506 410*405*24.5	410	405	24.5	25
506 410*405*29.5	410	405	29.5	30
506 415*407*39.5	415	407	39.5	40
506 420*412*24.5	420	412	24.5	25
506 420*412*39.5	420	412	39.5	40
506 420*414*29.5	420	414	29.5	30
506 420*415*14.7	420	415	14.7	15
506 420*415*19.5	420	415	19.5	20
506 420*415*24.5	420	415	24.5	25
506 420*415*29.5	420	415	29.5	30
506 430*423.65*25	430	423.7	25	25.4
506 435*427*24.5	435	427	24.5	25
506 435*430*9.4	435	430	9.4	9.7
506 440*432*24.5	440	432	24.5	25
506 440*435*29.5	440	435	29.5	30
506 450*442*24.5	450	442	24.5	25
506 450*442*39.5	450	442	39.5	40
506 450*445*19.5	450	445	19.5	20
506 450*445*24.5	450	445	24.5	25
506 450*445*29.5	450	445	29.5	30
506 450*445*39.5	450	445	39.5	40
506 460*452*24.5	460	452	24.5	25
506 460*452*39.5	460	452	39.5	40

导向/耐磨环

GUIDE RING WEAR RING

编号 Part No	外径 øD	内径 ød	高度 h	槽宽 I
506 460*455*24.5	460	455	24.5	25
506 480*475*29.5	480	475	29.5	30
506 480*475*39.5	480	475	39.5	40
506 500*492*6	500	492	6	6.1
506 500*492*24.5	500	492	24.5	25
506 500*492*29.5	500	492	29.5	30
506 500*492*39.5	500	492	39.5	40
506 500*494*19.5	500	494	19.5	20
506 500*495*24.5	500	495	24.5	25
506 500*495*29.5	500	495	29.5	30
506 508*503*24.5	508	503	24.5	25
506 510*505*29.5	510	505	29.5	30
506 520*512*24.5	520	512	24.5	25
506 520*515*24.5	520	515	24.5	25
506 530*525*39.5	530	525	39.5	40
506 535*527*24.5	535	527	24.5	25
506 540*532*24.5	540	532	24.5	25
506 545*540*24.5	545	540	24.5	25
506 560*555*24.5	560	555	24.5	25
506 580*572*24.5	580	572	24.5	25
506 600*595*24.5	600	595	24.5	25
506 620*612*24.5	620	612	24.5	25
506 630*622*29.5	630	622	29.5	30
506 640*632*24.5	640	632	24.5	25
506 1000*995*24.5	1000	995	24.5	25
506 5170*5162*19.5	5170	5162	19.5	20

编号 Part No	外径 øD	内径 ød	高度 h	槽宽 I

# NSB (N4B)

## 活塞杆密封 ROD SEAL

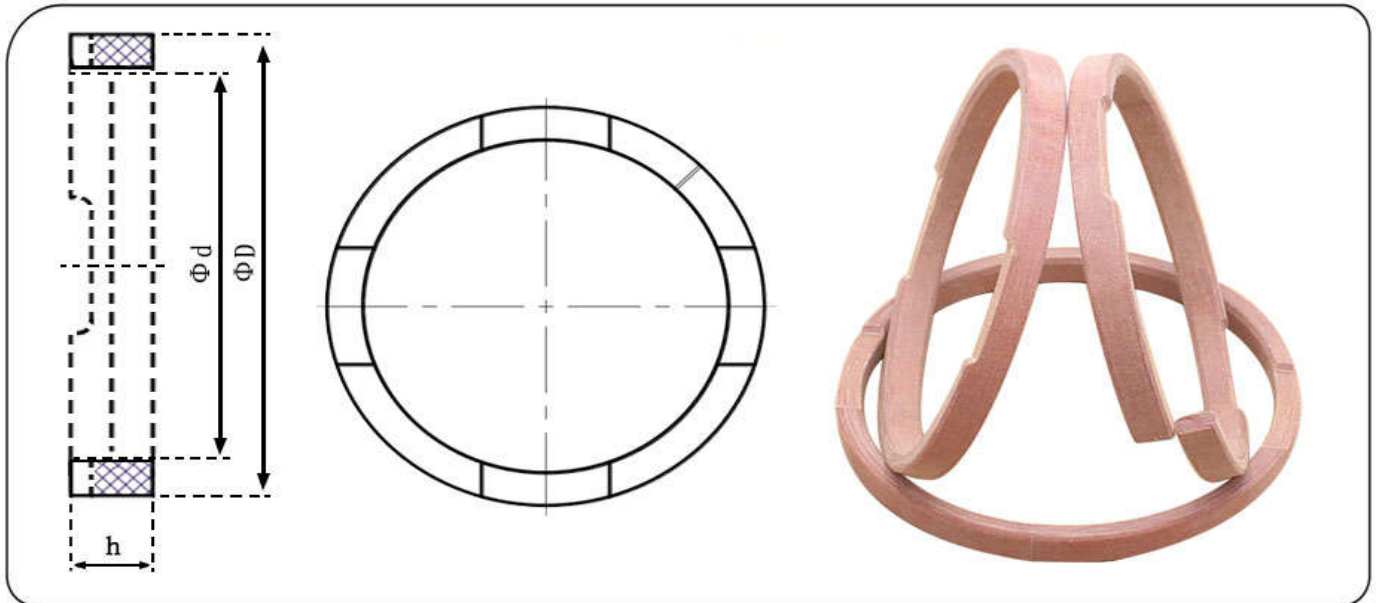

编号 Part No.	OD øD	ID ød	H h
NSB-24-19-3.5	24	19	3.5
NSB-38-32-6	38	32	6
NSB-39-33-6	39	33	6
NSB-46-41-6	46	41	6
NSB-52-46-6	52	46	6
NSB-54-48-6	54	48	6
NSB-60-55-6	60	55	6
NSB-64-54-6	64	54	6
NSB-64-58-6	64	58	6
NSB-68-53-6	67.5	52.5	6
NSB-69-59-6	69	59	6
NSB-69-63-6	69	63	6
NSB-69-59-8	69	59	8
NSB-70-60-8	70	60	8
NSB-70-64-8	70	64	8
NSB-72-66-6	72	66	6
NSB-72-66-8	72	66	8
NSB-74-64-6	74	64	6
NSB-74-68-6	74	68	6
NSB-74-64-8	74	64	8
NSB-75-69-8	75	69	8
NSB-76-69-8	76	69	8
NSB-79-69-8	79	69	8
NSB-79-69-10	79	69	10
NSB-80-74-6	80	74	6
NSB-80-75-6	80	75	6
NSB-83-78-6	82.5	77.5	6
NSB-84-74-8	84	74	8
NSB-85-80-6	85	80	6
NSB-85-75-10	85	75	10

编号 Part No.	OD øD	ID ød	H h
NSB-89-79-8	89	79	8
NSB-89-79-10	89	79	10
NSB-90-84-6	90	84	6
NSB-93-88-6	92.5	87.5	6
NSB-94-84-8	94	84	8
NSB-94-84-10	94	84	10
NSB-95-89-6	95	89	6
NSB-95-90-6	95	90	6
NSB-99-89-8	99	89	8
NSB-100-90-10	100	90	10
NSB-100-94-6	100	94	6
NSB-100-95-6	100	95	6
NSB-100-90-10	100	90	10
NSB-104-94-8	104	94	8
NSB-104-94-10	104	94	10
NSB-110-100-10	110	100	10
NSB-118-108-10	118	108	10
NSB-119-109-8	119	109	8
NSB-128-116-10	128	116	10
NSB-134-122-10	134	122	10

# ROS (ROI)

## 旋转密封

### ROTARY SHAFT SEAL

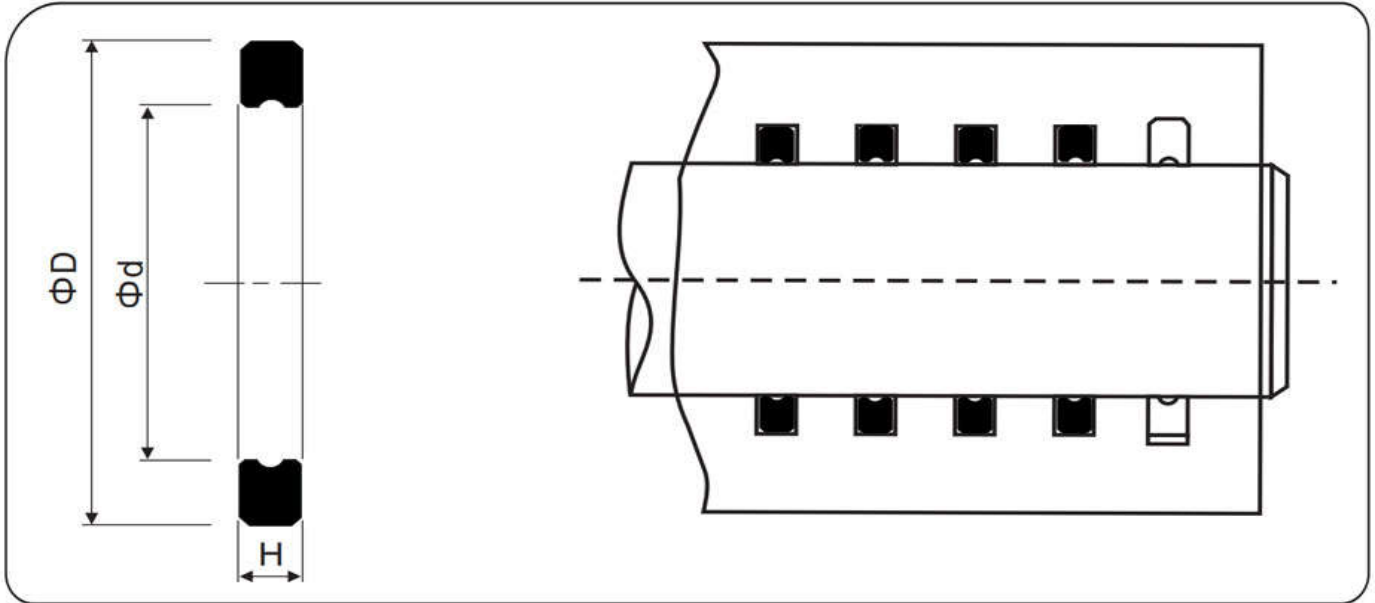

编号 Part No.	内径 ød	外径 øD	高度 H
ROS 50	50	60	4.8
ROS 55	55	64	4.6
ROS 60	60	70	4.8
ROS 70	70	80	4.8
ROS 75	75	85	4.8
ROS 80	80	90	4.8
ROS 85	85	95	4.8
ROS 90	90	100	4.8
ROS 95	95	105	4.8
ROS 100	100	110	4.8
ROS 105	105	115	4.8
ROS 110	110	120	4.8
ROS 115	115	125	4.8
ROS 120	120	130	4.8
ROS 125	125	135	4.8
ROS 130	130	140	4.8
ROS 135	135	145	4.8
ROS 140	140	150	4.8
ROS 150	150	160	4.8

编号 Part No.	内径 ød	外径 øD	高度 H

旋转密封  
ROTARY SAFT SEAL

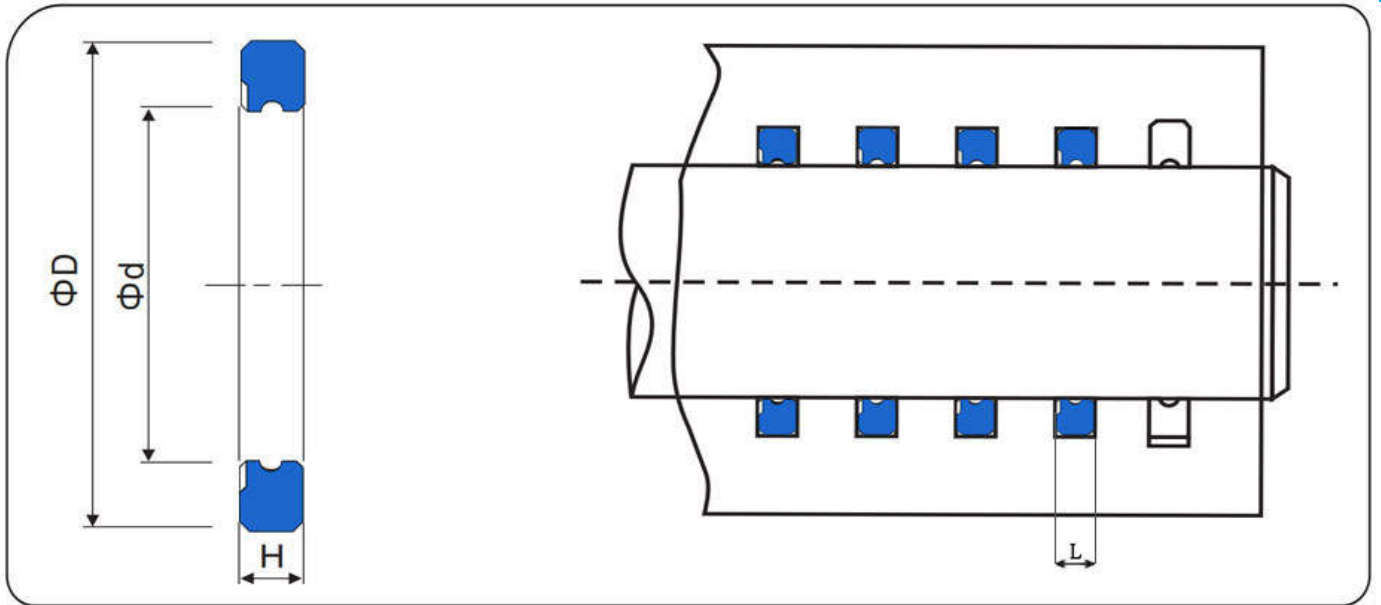

编号 Part No.	内径 ød	外径 øD	槽宽 L
80 57.2*70*7.5	57.2	70	7.5
80 80*90*5	80	90	5
80 90*100*5	90	100	5
80 95*105*5	95	105	5
80 100*110*5	100	110	5
80 125*135.4*5	125	135.4	5

编号 Part No.	内径 ød	外径 øD	槽宽 L



SPN

旋转密封

ROTARY SHAFT SEAL

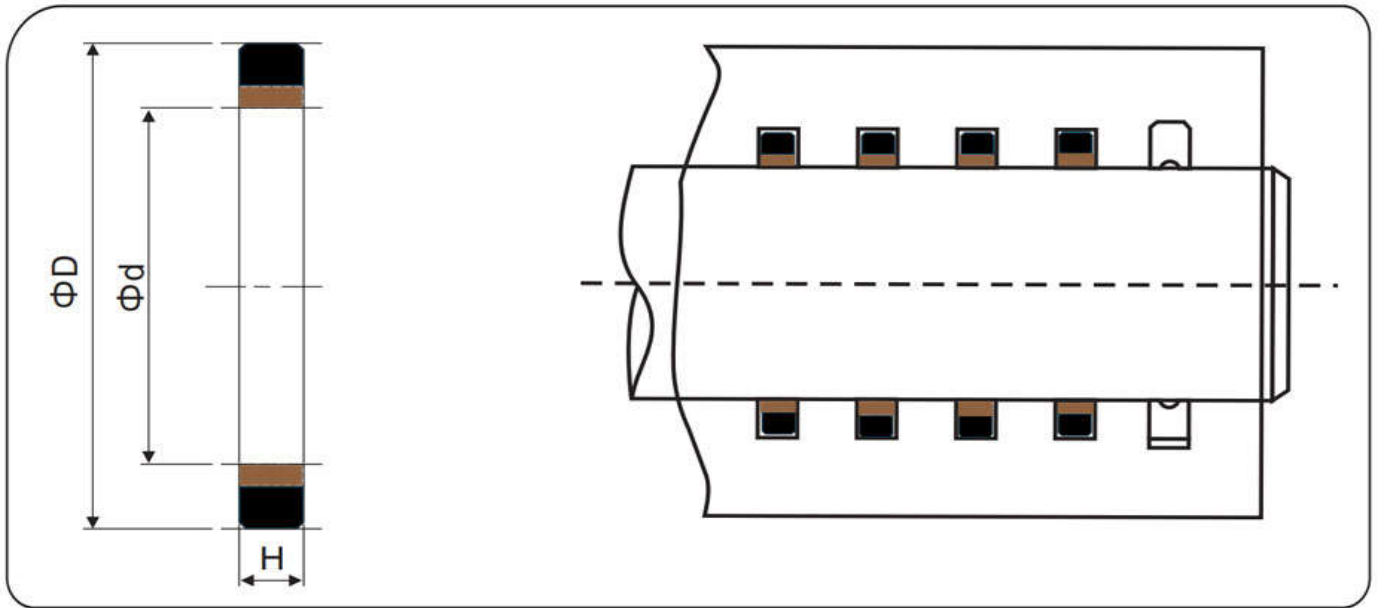

编号 Part No.	内径 $\phi d$	外径 $\phi D$	高度 H
SPN 50*4.8	50	60	4.8
SPN 55*4.8	55	65	4.8
SPN 60*4.8	60	70	4.8
SPN 70*4.8	70	80	4.8
SPN 80*4.8	80	90	4.8
SPN 90*4.8	90	100	4.8
SPN 95*4.8	95	105	4.8
SPN 100*4.8	100	110	4.8
SPN 105*4.8	105	115	4.8
SPN 110*4.8	110	100	4.8
SPN 120*4.8	120	130	4.8
SPN 125*4.8	125	135	4.8
SPN 130*4.8	130	140	4.8
SPN 140*4.8	140	150	4.8

编号 Part No.	内径 $\phi d$	外径 $\phi D$	高度 H

GRS

旋转密封  
ROTARY SHAFT SEAL

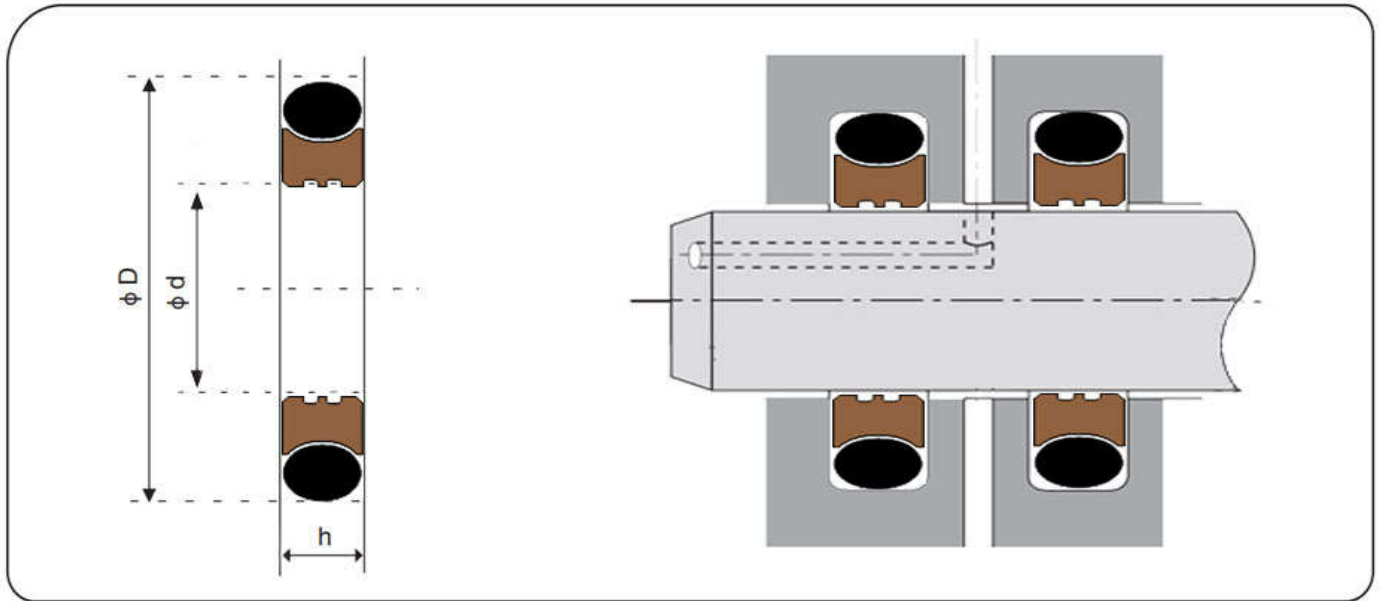

编号 Part No.	内径 ød	外径 øD	高度 h
GRS 50*4	50	61	4
GRS 60*4	60	71	4
GRS 65*4	65	76	4
GRS 70*4	70	81	4
GRS 75*4	75	86	4
GRS 80*4	80	91	4
GRS 85*4	85	96	4
GRS 90*4	90	101	4
GRS 95*4	95	106	4
GRS 100*4	100	111	4
GRS 105*4	105	116	4
GRS 120*4	120	131	4
GRS 100*6	100	107	6
GRS 110*6	110	117	6
GRS 120*6	120	127	6
GRS 130*6	130	137	6
GRS 140*6	140	147	6
GRS 150*6	150	157	6
GRS 160*6	160	167	6
GRS 180*6	180	187	6
GRS 200*6	200	207	6

编号 Part No.	内径 ød	外径 øD	高度 h

# N4W

## 承托环 BACK-UP RING

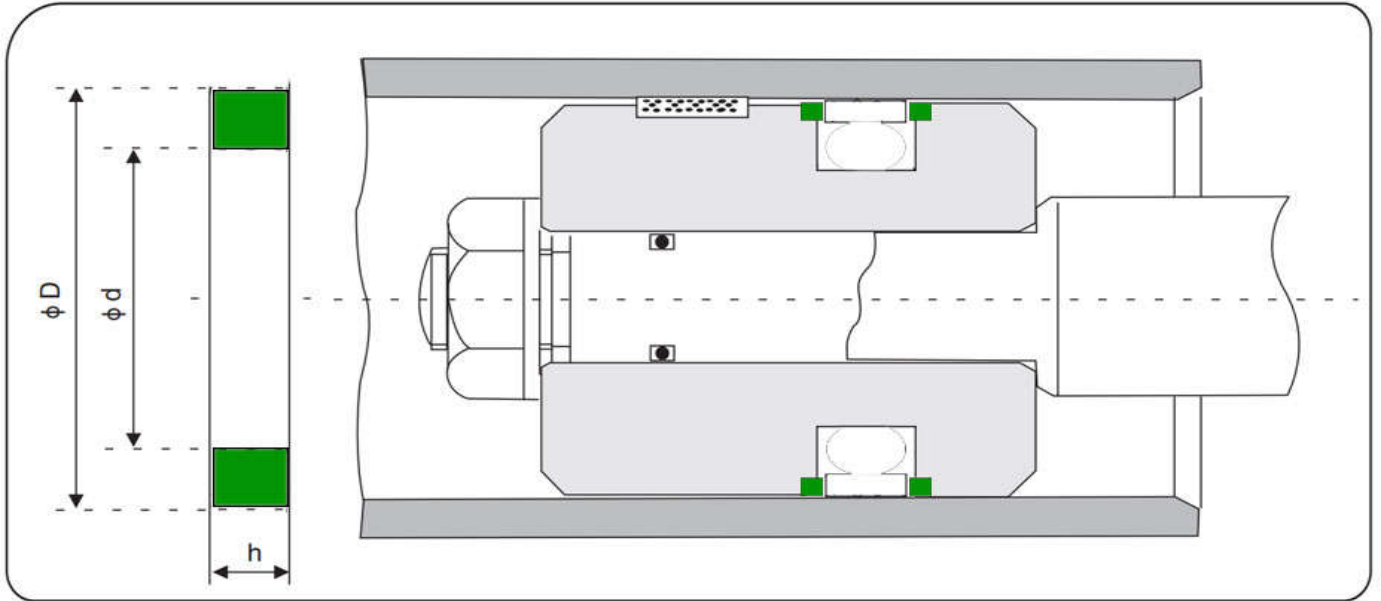

编号 Part No.	外径 φD	内径 φd	高度 h
N4W 85	85	80	2.5
N4W 90	90	85	2.5
N4W 95	95	90	2.5
N4W 100	100	95	2.5
N4W 105	105	100	2.5
N4W 110	110	104	3
N4W 115	115	109	3
N4W 120	120	114	3
N4W 125	125	119	3
N4W 130	130	124	3
N4W 135	135	129	3
N4W 140	140	134	3
N4W 145	145	139	3
N4W 150	150	144	3
N4W 160	160	154	3
N4W 170	170	164	3
N4W 180	180	174	3
N4W 185	185	179	3

编号 Part No.	外径 φD	内径 φd	高度 h

# BRT

## 承托环

### BACK-UP RING

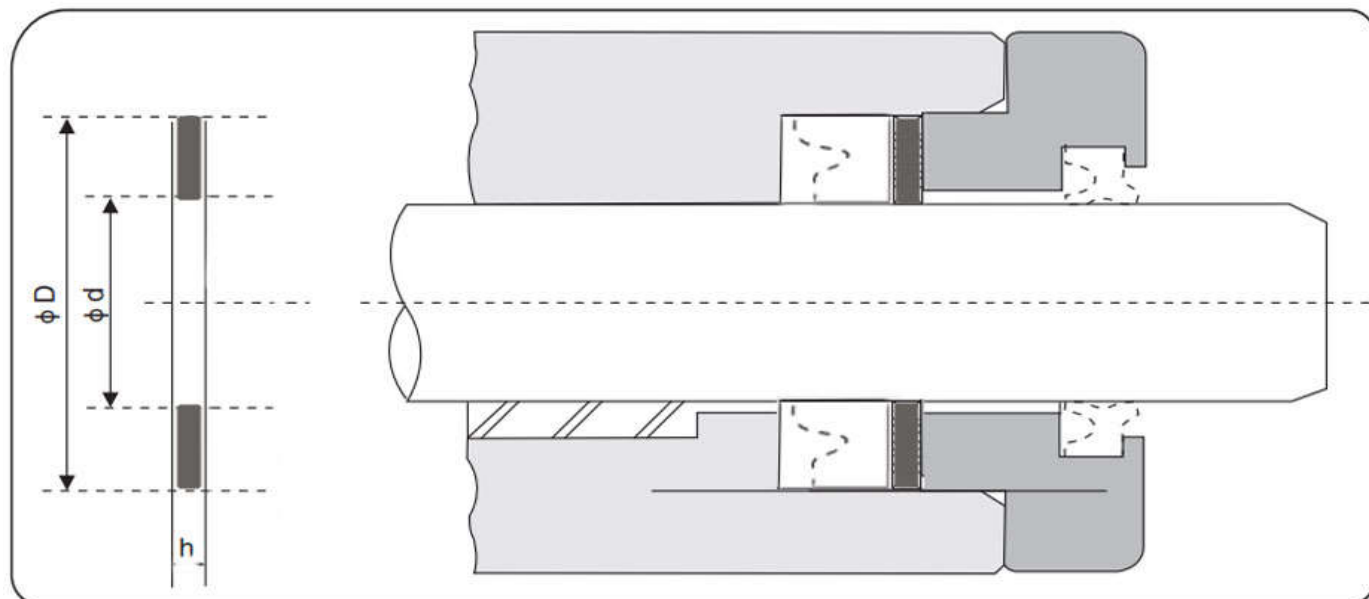

编号 Part No.	内径 φd	外径 φD	高度 h
BRT-NY 25*40*3	25	40	3
BRT-NY 30*40*3	30	40	3
BRT-NY 30*45*3	30	45	3
BRT-NY 32*48*3	32	48	3
BRT-NY 35*45*3	35	45	3
BRT-NY 35*50*3	35	50	3
BRT-NY 40*50*3	40	50	3
BRT-NY 40*55*3	40	55	3
BRT-NY 45*55*3	45	55	3
BRT-NY 45*60*3	45	60	3
BRT-NY 50*60*3	50	60	3
BRT-NY 50*63*3	50	63	3
BRT-NY 50*65*3	50	65	3
BRT-NY 50*70*3	50	70	3
BRT-NY 55*65*3	55	65	3
BRT-NY 55*68*3	55	68	3
BRT-NY 55*70*3	55	70	3
BRT-NY 55*75*3	55	75	3
BRT-NY 60*70*3	60	70	3
BRT-NY 60*73*3	60	73	3
BRT-NY 60*75*3	60	75	3
BRT-NY 60*80*3	60	80	3
BRT-NY 65*75*3	65	75	3
BRT-NY 65*78*3	65	78	3
BRT-NY 65*80*3	65	80	3
BRT-NY 65*85*3	65	85	3
BRT-NY 70*80*3	70	80	3
BRT-NY 70*83*3	70	83	3
BRT-NY 70*85*3	70	85	3
BRT-NY 70*90*3	70	90	3

编号 Part No.	内径 φd	外径 φD	高度 h
BRT-NY 75*85*3	75	85	3
BRT-NY 75*88*3	75	88	3
BRT-NY 75*90*3	75	90	3
BRT-NY 75*95*3	75	95	3
BRT-NY 80*90*3	80	90	3
BRT-NY 80*93*3	80	93	3
BRT-NY 80*95*3	80	95	3
BRT-NY 80*100*3	80	100	3
BRT-NY 85*100*3	85	100	3
BRT-NY 85*105*3	85	105	3
BRT-NY 90*105*3	90	105	3
BRT-NY 90*110*3	90	110	3
BRT-NY 95*110*3	95	110	3
BRT-NY 95*115*3	95	115	3
BRT-NY 100*115*3	100	115	3
BRT-NY 100*120*3	100	120	3
BRT-NY 105*120*3	105	120	3
BRT-NY 105*125*3	105	125	3
BRT-NY 110*120*3	110	120	3
BRT-NY 110*125*3	110	125	3
BRT-NY 110*130*3	110	130	3
BRT-NY 115*130*3	115	130	3
BRT-NY 115*135*3	115	135	3
BRT-NY 120*135*3	120	135	3
BRT-NY 120*140*3	120	140	3
BRT-NY 125*140*3	125	140	3
BRT-NY 125*145*3	125	145	3
BRT-NY 130*145*3	130	145	3
BRT-NY 130*150*3	130	150	3
BRT-NY 135*150*3	135	150	3

# O-RING

## O型密封圈

### O-RING SEAL

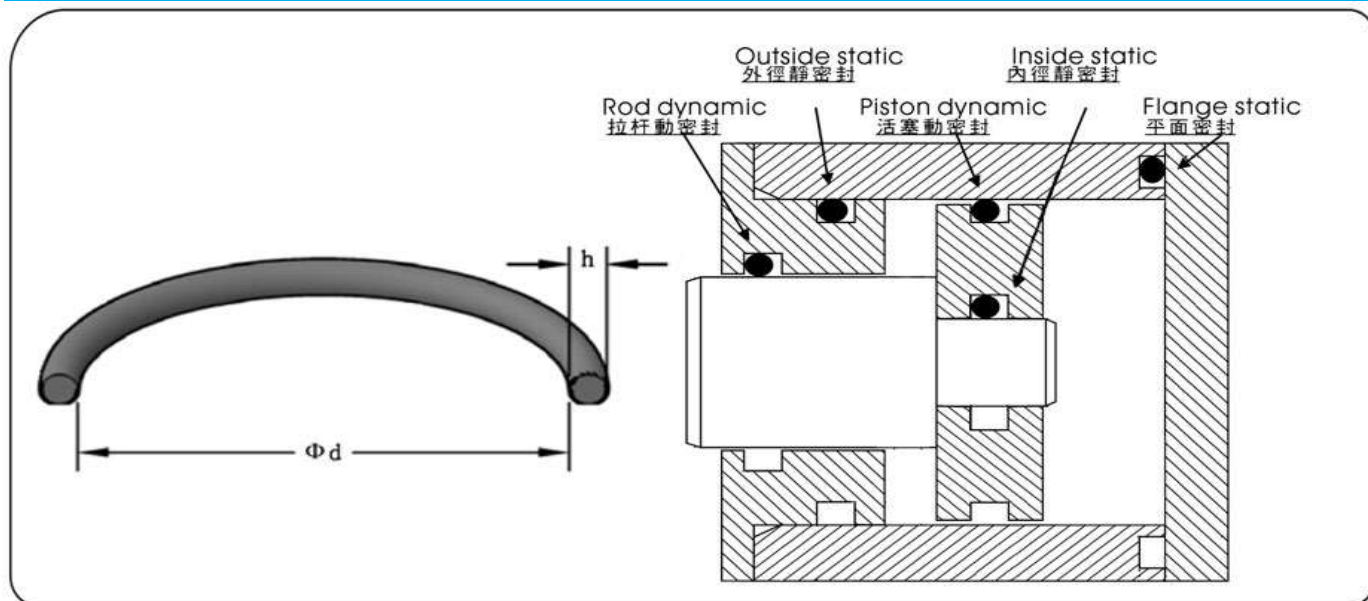

### G系列

编号 Part No.	内径 $\phi d$	线径 h	编号 Part No.	内径 $\phi d$	线径 h	编号 Part No.	内径 $\phi d$	线径 h
G25	24.4	3.1	G170	169.3	5.7	G320	319.3	5.7
G30	29.4	3.1	G175	174.3	5.7	G325	324.3	5.7
G35	34.4	3.1	G180	179.3	5.7	G330	329.3	5.7
G40	39.4	3.1	G185	184.3	5.7	G335	334.3	5.7
G45	44.4	3.1	G190	189.3	5.7	G340	339.3	5.7
G50	49.4	3.1	G195	194.3	5.7	G345	344.3	5.7
G55	54.4	3.1	G200	199.3	5.7	G350	349.3	5.7
G60	59.4	3.1	G205	204.3	5.7	G355	354.3	5.7
G65	64.4	3.1	G210	209.3	5.7	G360	359.3	5.7
G70	69.4	3.1	G215	214.3	5.7	G365	364.3	5.7
G75	74.4	3.1	G220	219.3	5.7	G370	369.3	5.7
G80	79.4	3.1	G225	224.3	5.7	G375	374.3	5.7
G85	84.4	3.1	G230	229.3	5.7	G380	379.3	5.7
G90	89.4	3.1	G235	234.3	5.7	G385	384.3	5.7
G95	94.4	3.1	G240	239.3	5.7	G390	389.3	5.7
G100	99.4	3.1	G245	244.3	5.7	G395	394.3	5.7
G105	104.4	3.1	G250	249.3	5.7	G400	399.3	5.7
G110	109.4	3.1	G255	254.3	5.7	G445	444.3	5.7
G115	114.4	3.1	G260	259.3	5.7			
G120	119.4	3.1	G265	264.3	5.7			
G125	124.4	3.1	G270	269.3	5.7			
G130	129.4	3.1	G275	274.3	5.7			
G135	134.4	3.1	G280	279.3	5.7			
G140	139.4	3.1	G285	284.3	5.7			
G145	144.4	3.1	G290	289.3	5.7			
			G295	294.3	5.7			
G150	149.3	5.7	G300	299.3	5.7			
G155	154.3	5.7	G305	304.3	5.7			
G160	159.3	5.7	G310	309.3	5.7			
G165	164.3	5.7	G315	314.3	5.7			

# O-RING

## O型密封圈 O-RING SEAL

P系列										
编号 Part No	内径 ød	线径 h		编号 Part No	内径 ød	线径 h		编号 Part No	内径 ød	线径 h
P3	2.8	1.9		P41	40.7	3.5		P180	179.5	8.4
P4	3.8	1.9		P42	41.7	3.5		P185	184.5	8.4
P5	4.8	1.9		P43	42.7	3.5		P190	189.5	8.4
P6	5.8	1.9		P44	43.7	3.5		P195	194.5	8.4
P7	6.8	1.9		P45	44.7	3.5		P200	199.5	8.4
P8	7.8	1.9		P46	45.7	3.5		P205	204.5	8.4
P9	8.8	1.9		P48	47.7	3.5		P210	209.5	8.4
P10	9.8	1.9		P49	48.7	3.5		P215	214.5	8.4
				P50	49.7	3.5		P220	219.5	8.4
P9A	8.8	2.4						P225	224.5	8.4
P10A	9.8	2.4		P40A	39.6	5.7		P230	229.5	8.4
P11	10.8	2.4		P48A	47.6	5.7		P235	234.5	8.4
11.2	11	2.4		P50A	49.6	5.7		P240	239.5	8.4
P12	11.8	2.4		P52	51.6	5.7		P245	244.5	8.4
P12.5	12.3	2.4		P53	52.6	5.7		P250	249.5	8.4
P13	12.8	2.4		P55	54.6	5.7		P255	254.5	8.4
P14	13.8	2.4		P56	55.6	5.7		P260	259.5	8.4
P15	14.8	2.4		P58	57.6	5.7		P265	264.5	8.4
P16	15.8	2.4		P60	59.6	5.7		P270	269.5	8.4
P17	16.8	2.4		P62	61.6	5.7		P275	274.5	8.4
P18	17.8	2.4		P65	64.6	5.7		P280	279.5	8.4
P19	18.8	2.4		P70	69.6	5.7		P285	284.5	8.4
P20	19.8	2.4		P75	74.6	5.7		P290	289.5	8.4
P21	20.8	2.4		P80	79.6	5.7		P295	294.5	8.4
P22	21.8	2.4		P85	84.6	5.7		P300	299.5	8.4
				P90	89.6	5.7		P305	304.5	8.4
P21A	20.7	3.5		P95	94.6	5.7		P310	309.5	8.4
P22A	21.7	3.5		P100	99.6	5.7		P315	314.5	8.4
P22.4	22	3.5		P102	101.6	5.7		P320	319.5	8.4
P23	22.7	3.5		P105	104.6	5.7		P325	324.5	8.4
P24	23.7	3.5		P110	109.6	5.7		P330	329.5	8.4
P25	24.7	3.5		P112	111.6	5.7		P335	334.5	8.4
P26	25.7	3.5		P115	114.6	5.7		P340	339.5	8.4
P27	26.7	3.5		P120	119.6	5.7		P345	344.5	8.4
P28	27.7	3.5		P125	124.6	5.7		P350	349.5	8.4
P29	28.7	3.5		P130	129.6	5.7		P355	354.5	8.4
P29.5	29.2	3.5		P132	131.6	5.7		P360	359.5	8.4
P30	29.7	3.5		P135	134.6	5.7		P365	364.5	8.4
P31	30.7	3.5		P140	139.6	5.7		P370	369.5	8.4
P32	31.7	3.5		P145	144.6	5.7		P375	374.5	8.4
P33	32.7	3.5		P150	149.6	5.7		P380	379.5	8.4
P34	33.7	3.5						P385	384.5	8.4
P35	34.7	3.5		P150A	149.5	8.4		P390	389.5	8.4
P36	35.7	3.5		P155	154.5	8.4		P395	394.5	8.4
P37	36.7	3.5		P160	159.5	8.4		P400	399.5	8.4
P38	37.7	3.5		P165	164.5	8.4				
P39	38.7	3.5		P170	169.5	8.4				
P40	39.7	3.5		P175	174.5	8.4				

# O-RING

## O型密封圈 O-RING SEAL

### AS系列

编号 Part No	内径 ød	线径 h	编号 Part No	内径 ød	线径 h	编号 Part No	内径 ød	线径 h
AS004	1.78	1.78	AS102	1.24	2.62	AS150	72.69	2.62
AS005	2.57	1.78	AS103	2.06	2.62	AS151	75.87	2.62
AS006	2.9	1.78	AS104	2.85	2.62	AS152	82.22	2.62
AS007	3.68	1.78	AS105	3.63	2.62	AS153	88.57	2.62
AS008	4.47	1.78	AS106	4.42	2.62	AS154	94.93	2.62
AS009	5.28	1.78	AS107	5.23	2.62	AS155	101.27	2.62
AS010	6.07	1.78	AS108	6.02	2.62	AS156	107.62	2.62
AS011	7.65	1.78	AS109	7.59	2.62	AS157	113.98	2.62
AS012	9.25	1.78	AS110	9.19	2.62	AS158	120.32	2.62
AS013	10.85	1.78	AS111	10.77	2.62	AS159	126.67	2.62
AS014	12.42	1.78	AS112	12.37	2.62	AS160	133.02	2.62
AS015	14	1.78	AS113	13.94	2.62	AS161	139.37	2.62
AS016	15.6	1.78	AS114	15.54	2.62	AS162	145.72	2.62
AS017	17.17	1.78	AS115	17.12	2.62	AS163	152.07	2.62
AS018	18.77	1.78	AS116	18.72	2.62	AS164	158.42	2.62
AS019	20.35	1.78	AS117	20.29	2.62	AS165	164.77	2.62
AS020	21.95	1.78	AS118	21.89	2.62	AS166	171.14	2.62
AS021	23.52	1.78	AS119	23.47	2.62	AS167	177.47	2.62
AS022	25.12	1.78	AS120	25.07	2.62	AS168	183.82	2.62
AS023	26.7	1.78	AS121	26.64	2.62	AS169	190.18	2.62
AS024	28.3	1.78	AS122	28.24	2.62	AS170	196.52	2.62
AS025	29.87	1.78	AS123	29.82	2.62	AS171	202.87	2.62
AS026	31.47	1.78	AS124	31.42	2.62	AS172	209.22	2.62
AS027	33.05	1.78	AS125	32.99	2.62	AS173	215.57	2.62
AS028	34.65	1.78	AS126	34.59	2.62	AS174	221.92	2.62
AS029	37.82	1.78	AS127	36.17	2.62	AS175	228.27	2.62
AS030	41	1.78	AS128	37.77	2.62	AS176	234.62	2.62
AS031	44.17	1.78	AS129	39.34	2.62	AS177	240.97	2.62
AS032	47.35	1.78	AS130	40.94	2.62	AS178	247.32	2.62
AS033	50.52	1.78	AS131	42.52	2.62			
AS034	53.7	1.78	AS132	44.12	2.62	AS201	4.34	3.53
AS035	56.87	1.78	AS133	45.69	2.62	AS202	5.94	3.53
AS036	60.05	1.78	AS134	47.29	2.62	AS203	7.52	3.53
AS037	63.22	1.78	AS135	48.9	2.62	AS204	9.12	3.53
AS038	66.4	1.78	AS136	50.47	2.62	AS205	10.69	3.53
AS039	69.57	1.78	AS137	52.07	2.62	AS206	12.29	3.53
AS040	72.75	1.78	AS138	53.64	2.62	AS207	13.87	3.53
AS041	75.92	1.78	AS139	55.25	2.62	AS208	15.47	3.53
AS042	82.27	1.78	AS140	56.82	2.62	AS209	17.04	3.53
AS043	88.62	1.78	AS141	58.42	2.62	AS210	18.64	3.53
AS044	94.97	1.78	AS142	59.99	2.62	AS211	20.22	3.53
AS045	101.32	1.78	AS143	61.6	2.62	AS212	21.82	3.53
AS046	107.67	1.78	AS144	63.17	2.62	AS213	23.39	3.53
AS047	114.02	1.78	AS145	64.77	2.62	AS214	24.99	3.53
AS048	120.37	1.78	AS146	66.34	2.62	AS215	26.57	3.53
AS049	126.72	1.78	AS147	67.95	2.62	AS216	28.17	3.53
AS050	133.07	1.78	AS148	69.52	2.62	AS217	29.74	3.53
			AS149	71.2	2.62	AS218	31.34	3.53

# O-RING

## O型密封圈 O-RING SEAL

AS系列										
编号 Part No	内径 ød	线径 h		编号 Part No	内径 ød	线径 h		编号 Part No	内径 ød	线径 h
AS219	32.92	3.53		AS267	209.14	3.53		AS338	78.74	5.33
AS220	34.52	3.53		AS268	215.49	3.53		AS339	81.92	5.33
AS221	36.09	3.53		AS269	221.84	3.53		AS340	85.09	5.33
AS222	37.69	3.53		AS270	228.19	3.53		AS341	88.27	5.33
AS223	40.86	3.53		AS271	234.54	3.53		AS342	91.44	5.33
AS224	44.05	3.53		AS272	240.89	3.53		AS343	94.62	5.33
AS225	47.22	3.53		AS273	247.24	3.53		AS344	97.79	5.33
AS226	50.39	3.53		AS274	253.39	3.53		AS345	100.97	5.33
AS227	53.57	3.53		AS275	266.29	3.53		AS346	104.14	5.33
AS228	56.74	3.53		AS276	278.99	3.53		AS347	107.32	5.33
AS229	59.92	3.53		AS277	291.69	3.53		AS348	110.49	5.33
AS230	63.09	3.53		AS278	304.39	3.53		AS349	113.67	5.33
AS231	66.27	3.53		AS279	329.79	3.53		AS350	116.84	5.33
AS232	69.44	3.53		AS280	355.19	3.53		AS351	120.02	5.33
AS233	72.62	3.53		AS281	380.59	3.53		AS352	123.19	5.33
AS234	75.79	3.53		AS282	405.26	3.53		AS353	126.37	5.33
AS235	78.97	3.53		AS283	430.66	3.53		AS354	129.54	5.33
AS236	82.14	3.53		AS284	456.06	3.53		AS355	132.72	5.33
AS237	85.32	3.53						AS356	135.89	5.33
AS238	88.49	3.53		AS309	10.46	5.33		AS357	139.07	5.33
AS239	91.67	3.53		AS310	12.07	5.33		AS358	142.24	5.33
AS240	94.84	3.53		AS311	13.64	5.33		AS359	145.42	5.33
AS241	98.02	3.53		AS312	15.24	5.33		AS360	148.59	5.33
AS242	101.19	3.53		AS313	16.81	5.33		AS361	151.77	5.33
AS243	104.37	3.53		AS314	18.42	5.33		AS362	158.12	5.33
AS244	107.54	3.53		AS315	19.99	5.33		AS363	164.47	5.33
AS245	110.72	3.53		AS316	21.59	5.33		AS364	170.82	5.33
AS246	113.9	3.53		AS317	23.16	5.33		AS365	177.17	5.33
AS247	117.07	3.53		AS318	24.77	5.33		AS366	183.52	5.33
AS248	120.24	3.53		AS319	26.34	5.33		AS367	189.87	5.33
AS249	123.42	3.53		AS320	27.94	5.33		AS368	196.22	5.33
AS250	126.59	3.53		AS321	29.51	5.33		AS369	202.57	5.33
AS251	129.77	3.53		AS322	31.12	5.33		AS370	208.92	5.33
AS252	132.94	3.53		AS323	32.69	5.33		AS371	215.27	5.33
AS253	136.12	3.53		AS324	34.29	5.33		AS372	221.62	5.33
AS254	139.3	3.53		AS325	37.47	5.33		AS373	227.97	5.33
AS255	142.47	3.53		AS326	40.64	5.33		AS374	234.32	5.33
AS256	145.64	3.53		AS327	43.82	5.33		AS375	240.67	5.33
AS257	148.82	3.53		AS328	46.99	5.33		AS376	247.02	5.33
AS258	151.99	3.53		AS329	50.17	5.33		AS377	253.37	5.33
AS259	158.34	3.53		AS330	53.34	5.33		AS378	266.07	5.33
AS260	164.69	3.53		AS331	56.52	5.33		AS379	278.77	5.33
AS261	171.04	3.53		AS332	59.69	5.33		AS380	291.47	5.33
AS262	177.39	3.53		AS333	62.87	5.33		AS381	304.17	5.33
AS263	183.74	3.53		AS334	66.04	5.33		AS382	329.57	5.33
AS264	190.09	3.53		AS335	69.22	5.33		AS383	354.97	5.33
AS265	196.44	3.53		AS336	72.39	5.33		AS384	380.37	5.33
AS266	202.79	3.53		AS337	75.57	5.33		AS385	405.26	5.33



# O-RING

## O型密封圈 O-RING SEAL

AS系列										
编号 Part No	内径 ød	线径 h		编号 Part No	内径 ød	线径 h		编号 Part No	内径 ød	线径 h
AS386	430.66	5.33		AS901	4.7	1.42				
AS387	456.06	5.33		AS902	6.07	1.63				
AS388	481.46	5.33		AS903	7.64	1.63				
				AS904	8.92	1.83				
AS425	113.67	6.99		AS905	10.52	1.83				
AS426	116.84	6.99		AS906	11.89	1.98				
AS427	120.02	6.99		AS907	13.46	2.08				
AS428	123.19	6.99		AS908	16.36	2.21				
AS429	126.37	6.99		AS909	17.93	2.46				
AS430	129.54	6.99		AS910	19.18	2.46				
AS431	132.72	6.99		AS911	21.92	2.95				
AS432	135.89	6.99		AS912	23.47	2.95				
AS433	139.07	6.99		AS913	25.04	2.95				
AS434	142.24	6.99		AS914	26.59	2.95				
AS435	145.42	6.99		AS916	29.74	2.95				
AS436	148.59	6.99		AS918	34.42	2.95				
AS437	151.77	6.99		AS920	37.46	3				
AS438	158.12	6.99		AS924	43.69	3				
AS439	164.47	6.99		AS928	53.09	3				
AS440	170.82	6.99		AS932	59.36	3				
AS441	177.17	6.99								
AS443	189.87	6.99								
AS444	196.22	6.99								
AS445	202.57	6.99								
AS674	208.92	6.99								
AS446	215.27	6.99								
AS447	227.97	6.99								
AS448	240.67	6.99								
AS449	253.27	6.99								
AS450	266.07	6.99								
AS451	278.77	6.99								
AS452	291.47	6.99								
AS453	304.17	6.99								
AS454	316.87	6.99								
AS455	329.57	6.99								
AS456	342.27	6.99								
AS457	354.97	6.99								
AS458	367.67	6.99								
AS459	380.37	6.99								
AS460	393.07	6.99								
AS461	405.26	6.99								
AS462	417.96	6.99								
AS463	430.66	6.99								
AS464	443.36	6.99								
AS465	456.06	6.99								
AS466	468.76	6.99								
AS467	481.46	6.99								
AS468	494.16	6.99								

BRT0

承托环 BACK-UP RING

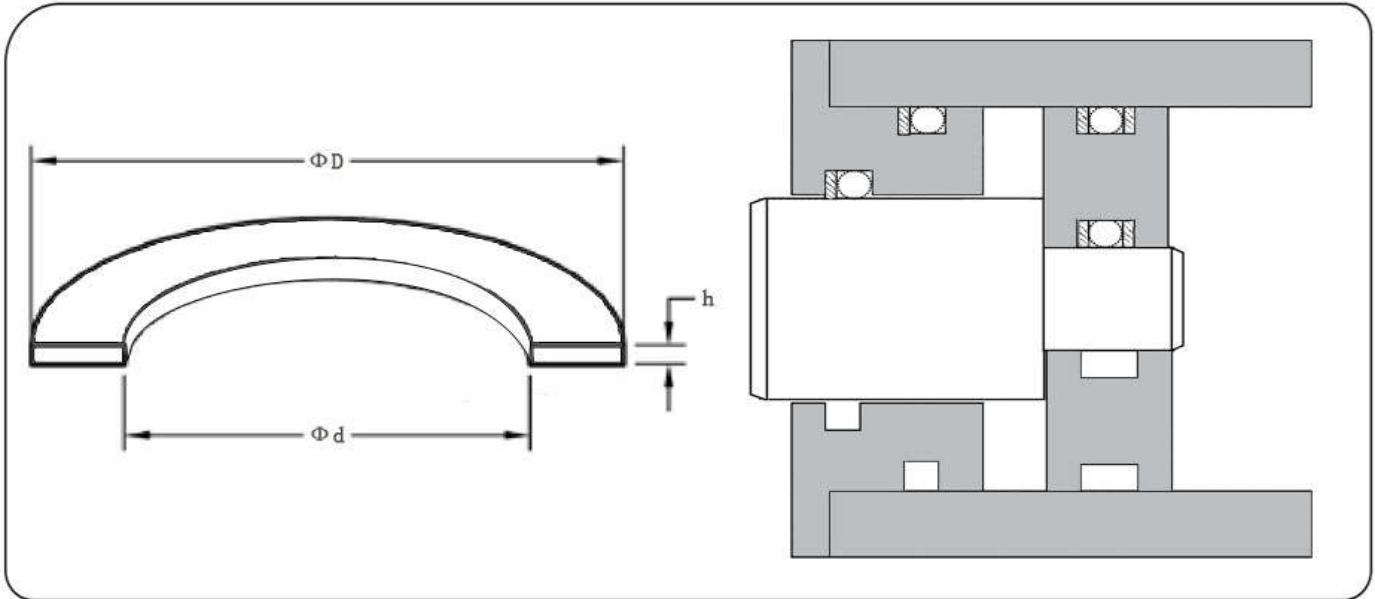

G系列

编号 Part No.	内径 ød	外径 øD	高度 h		编号 Part No.	内径 ød	外径 øD	高度 h		编号 Part No.	内径 ød	外径 øD	高度 h
G25	25	30	1.25		G160	160	170	1.9					
G30	30	35	1.25		G165	165	175	1.9					
G35	35	40	1.25		G170	170	180	1.9					
G40	40	45	1.25		G175	175	185	1.9					
G45	45	50	1.25		G180	180	190	1.9					
G50	50	55	1.25		G185	185	195	1.9					
G55	55	60	1.25		G190	190	200	1.9					
G60	60	65	1.25		G195	195	205	1.9					
G65	65	70	1.25		G200	200	210	1.9					
G70	70	75	1.25		G205	205	215	1.9					
G75	75	80	1.25		G210	210	220	1.9					
G80	80	85	1.25		G215	215	225	1.9					
G85	85	90	1.25		G220	220	230	1.9					
G90	90	95	1.25		G225	225	235	1.9					
G95	95	100	1.25		G230	230	240	1.9					
G100	100	105	1.25		G235	235	245	1.9					
G105	105	110	1.25		G240	240	250	1.9					
G110	110	115	1.25		G245	245	255	1.9					
G115	115	120	1.25		G250	250	260	1.9					
G120	120	125	1.25		G255	255	265	1.9					
G125	125	130	1.25		G260	260	270	1.9					
G130	130	135	1.25		G265	265	275	1.9					
G135	135	140	1.25		G270	270	280	1.9					
G140	140	145	1.25		G275	275	285	1.9					
G145	145	150	1.25		G280	280	290	1.9					
G150	150	155	1.25		G285	285	295	1.9					
G155	155	160	1.25		G290	290	300	1.9					
					G295	295	305	1.9					
G150	150	160	1.9		G300	300	310	1.9					
G155	155	165	1.9										

承托环  
BACK-UP RING

P系列													
编号 Part No	内径 ød	外径 øD	高度 h		编号 Part No	内径 ød	外径 øD	高度 h		编号 Part No	内径 ød	外径 øD	高度 h
P3	3	6	1.25		P48	48	54	1.25		P250	250	265	2.75
P4	4	7	1.25		P49	49	55	1.25		P255	255	270	2.75
P5	5	8	1.25		P50	50	56	1.25		P260	260	275	2.75
P6	6	9	1.25							P265	265	280	2.75
P7	7	10	1.25		P40A	40	50	1.9		P270	270	285	2.75
P8	8	11	1.25		P48A	48	58	1.9		P275	275	290	2.75
P9	9	12	1.25		P50A	50	60	1.9		P280	280	295	2.75
P10	10	13	1.25		P55	55	65	1.9		P285	285	300	2.75
P10A	10	14	1.25		P60	60	70	1.9		P290	290	305	2.75
P11	11	15	1.25		P65	65	75	1.9		P295	295	310	2.75
P12	12	16	1.25		P70	70	80	1.9		P300	300	315	2.75
P13	13	17	1.25		P75	75	85	1.9		P305	305	320	2.75
P14	14	18	1.25		P80	80	90	1.9		P310	310	325	2.75
P14A	14	19	1.25		P85	85	95	1.9		P315	315	330	2.75
P15	15	19	1.25		P90	90	100	1.9		P320	320	335	2.75
P16	16	20	1.25		P95	95	105	1.9					
P17	17	21	1.25		P100	100	110	1.9					
P18	18	22	1.25		P105	105	115	1.9					
P19	19	23	1.25		P110	110	120	1.9					
P20	20	24	1.25		P115	115	125	1.9					
P21	21	25	1.25		P120	120	130	1.9					
P22	22	26	1.25		P125	125	135	1.9					
P22A	22	28	1.25		P130	130	140	1.9					
P23	23	29	1.25		P135	135	145	1.9					
P24	24	30	1.25		P140	140	150	1.9					
P25	25	31	1.25		P145	145	155	1.9					
P26	26	32	1.25		P150	150	160	1.9					
P27	27	33	1.25										
P28	28	34	1.25		P150A	150	165	2.75					
P29	29	35	1.25		P155	155	170	2.75					
P30	30	36	1.25		P160	160	175	2.75					
P31	31	37	1.25		P165	165	180	2.75					
P32	32	38	1.25		P170	170	185	2.75					
P33	33	39	1.25		P175	175	190	2.75					
P34	34	40	1.25		P180	180	195	2.75					
P35	35	41	1.25		P185	185	200	2.75					
P36	36	42	1.25		P190	190	205	2.75					
P37	37	43	1.25		P195	195	210	2.75					
P38	38	44	1.25		P200	200	215	2.75					
P39	39	45	1.25		P205	205	220	2.75					
P40	40	46	1.25		P210	210	225	2.75					
P41	41	47	1.25		P215	215	230	2.75					
P42	42	48	1.25		P220	220	235	2.75					
P43	43	49	1.25		P225	225	240	2.75					
P44	44	50	1.25		P230	230	245	2.75					
P45	45	51	1.25		P235	235	250	2.75					
P46	46	52	1.25		P240	240	255	2.75					
P47	47	53	1.25		P245	245	260	2.75					

## BRON(574)

## 承托环

## BACK-UP RING

编号 Part No.	内径 ød	外径 øD	高度 h	编号 Part No.	内径 ød	外径 øD	高度 h	编号 Part No.	内径 ød	外径 øD	高度 h
BRON-AS004	2.44	5.14	1.24	BRON-AS049	127.46	130.16	1.24	BRON-AS145	65.56	69.92	1.35
BRON-AS005	3.23	5.93	1.24	BRON-AS050	133.81	136.51	1.24	BRON-AS146	67.13	71.49	1.35
BRON-AS006	3.56	6.26	1.24	BRON-AS102	1.96	6.32	1.35	BRON-AS147	68.73	73.09	1.35
BRON-AS007	4.34	7.04	1.24	BRON-AS103	2.77	7.13	1.35	BRON-AS148	70.31	74.67	1.35
BRON-AS008	5.13	7.83	1.24	BRON-AS104	3.56	7.92	1.35	BRON-AS149	71.91	76.27	1.35
BRON-AS009	5.94	8.64	1.24	BRON-AS105	4.34	8.7	1.35	BRON-AS150	73.48	77.84	1.35
BRON-AS010	6.73	9.43	1.24	BRON-AS106	5.13	9.49	1.35	BRON-AS151	76.66	81.02	1.35
BRON-AS011	8.31	11.01	1.24	BRON-AS107	5.94	10.3	1.35	BRON-AS152	83.01	87.37	1.35
BRON-AS012	9.91	12.61	1.24	BRON-AS108	6.73	11.09	1.35	BRON-AS153	89.36	93.72	1.35
BRON-AS013	11.56	14.26	1.24	BRON-AS109	8.31	12.67	1.35	BRON-AS154	95.71	100.07	1.35
BRON-AS014	13.16	15.86	1.24	BRON-AS110	9.91	14.27	1.35	BRON-AS155	102.06	106.42	1.35
BRON-AS015	14.73	17.43	1.24	BRON-AS111	11.48	15.84	1.35	BRON-AS156	108.41	112.77	1.35
BRON-AS016	16.33	19.03	1.24	BRON-AS112	13.08	17.44	1.35	BRON-AS157	114.76	119.12	1.35
BRON-AS017	17.91	20.61	1.24	BRON-AS113	14.66	19.02	1.35	BRON-AS158	121.11	125.47	1.35
BRON-AS018	19.51	22.21	1.24	BRON-AS114	16.26	20.62	1.35	BRON-AS159	127.46	131.82	1.35
BRON-AS019	21.08	23.78	1.24	BRON-AS115	17.83	22.19	1.35	BRON-AS160	133.81	138.17	1.35
BRON-AS020	22.68	25.38	1.24	BRON-AS116	19.43	23.79	1.35	BRON-AS161	140.16	144.52	1.35
BRON-AS021	24.26	26.96	1.24	BRON-AS117	21.11	25.47	1.35	BRON-AS162	146.51	150.87	1.35
BRON-AS022	25.86	28.56	1.24	BRON-AS118	22.68	27.04	1.35	BRON-AS163	152.86	157.22	1.35
BRON-AS023	27.43	30.13	1.24	BRON-AS119	24.28	28.64	1.35	BRON-AS164	159.21	163.57	1.35
BRON-AS024	29.03	31.73	1.24	BRON-AS120	25.86	30.22	1.35	BRON-AS165	165.56	169.92	1.35
BRON-AS025	30.61	33.31	1.24	BRON-AS121	27.46	31.82	1.35	BRON-AS166	171.91	176.27	1.35
BRON-AS026	32.21	34.91	1.24	BRON-AS122	29.03	33.39	1.35	BRON-AS167	178.26	182.62	1.35
BRON-AS027	33.78	36.48	1.24	BRON-AS123	30.63	34.99	1.35	BRON-AS168	184.61	188.97	1.35
BRON-AS028	35.38	38.08	1.24	BRON-AS124	32.21	36.57	1.35	BRON-AS169	190.96	195.32	1.35
BRON-AS029	38.56	41.26	1.24	BRON-AS125	33.81	38.17	1.35	BRON-AS170	197.31	201.67	1.35
BRON-AS030	41.73	44.43	1.24	BRON-AS126	35.38	39.74	1.35	BRON-AS171	203.66	208.02	1.35
BRON-AS031	44.91	47.61	1.24	BRON-AS127	36.98	41.34	1.35	BRON-AS172	210.01	214.37	1.35
BRON-AS032	48.08	50.78	1.24	BRON-AS128	38.56	42.92	1.35	BRON-AS173	216.36	220.72	1.35
BRON-AS033	51.26	53.96	1.24	BRON-AS129	40.16	44.52	1.35	BRON-AS174	222.71	227.07	1.35
BRON-AS034	54.43	57.13	1.24	BRON-AS130	41.73	46.09	1.35	BRON-AS175	229.06	233.42	1.35
BRON-AS035	57.61	60.31	1.24	BRON-AS131	43.33	47.69	1.35	BRON-AS176	235.41	239.77	1.35
BRON-AS036	60.78	63.48	1.24	BRON-AS132	44.91	49.27	1.35	BRON-AS177	241.76	246.12	1.35
BRON-AS037	63.96	66.66	1.24	BRON-AS133	46.51	50.87	1.35	BRON-AS178	248.11	252.47	1.35
BRON-AS038	67.13	69.83	1.24	BRON-AS134	48.08	52.44	1.35	BRON-AS201	5.13	11.13	1.27
BRON-AS039	70.31	73.01	1.24	BRON-AS135	49.68	54.04	1.35	BRON-AS202	6.73	12.73	1.27
BRON-AS040	73.48	76.18	1.24	BRON-AS136	51.26	55.62	1.35	BRON-AS203	8.31	14.31	1.27
BRON-AS041	76.66	79.36	1.24	BRON-AS137	52.86	57.22	1.35	BRON-AS204	9.91	15.91	1.27
BRON-AS042	83.01	85.71	1.24	BRON-AS138	54.43	58.79	1.35	BRON-AS205	11.56	17.56	1.27
BRON-AS043	89.36	92.06	1.24	BRON-AS139	56.03	60.39	1.35	BRON-AS206	13.16	19.16	1.27
BRON-AS044	95.71	98.41	1.24	BRON-AS140	57.61	61.97	1.35	BRON-AS207	14.73	20.73	1.27
BRON-AS045	102.06	104.76	1.24	BRON-AS141	59.21	63.57	1.35	BRON-AS208	16.33	22.33	1.27
BRON-AS046	108.41	111.11	1.24	BRON-AS142	60.78	65.14	1.35	BRON-AS209	17.91	23.91	1.27
BRON-AS047	114.76	117.46	1.24	BRON-AS143	62.38	66.74	1.35	BRON-AS210	19.46	25.46	1.27
BRON-AS048	121.11	123.81	1.24	BRON-AS144	63.96	68.32	1.35	BRON-AS211	21.03	27.03	1.27

## BRON (574)

## 承托环

## BACK-UP RING

编号 Part No	内径 ød	外径 øD	高度 h	编号 Part No	内径 ød	外径 øD	高度 h	编号 Part No	内径 ød	外径 øD	高度 h
BRON-AS212	22.63	28.63	1.27	BRON-AS260	165.56	171.56	1.27	BRON-AS332	60.78	70.08	1.93
BRON-AS213	24.21	30.21	1.27	BRON-AS261	171.91	177.91	1.27	BRON-AS333	63.96	73.26	1.93
BRON-AS214	25.81	31.81	1.27	BRON-AS262	178.26	184.26	1.27	BRON-AS334	67.13	76.43	1.93
BRON-AS215	27.38	33.38	1.27	BRON-AS263	184.61	190.61	1.27	BRON-AS335	70.31	79.61	1.93
BRON-AS216	28.98	34.98	1.27	BRON-AS264	190.96	196.96	1.27	BRON-AS336	73.48	82.78	1.93
BRON-AS217	30.56	36.56	1.27	BRON-AS265	197.31	203.31	1.27	BRON-AS337	76.66	85.96	1.93
BRON-AS218	32.16	38.16	1.27	BRON-AS266	203.66	209.66	1.27	BRON-AS338	79.83	89.13	1.93
BRON-AS219	33.88	39.88	1.27	BRON-AS267	210.01	216.01	1.27	BRON-AS339	83.13	92.43	1.93
BRON-AS220	35.48	41.48	1.27	BRON-AS268	216.36	222.36	1.27	BRON-AS340	86.31	95.61	1.93
BRON-AS221	37.06	43.06	1.27	BRON-AS269	222.71	228.71	1.27	BRON-AS341	89.48	98.78	1.93
BRON-AS222	38.66	44.66	1.27	BRON-AS270	229.06	235.06	1.27	BRON-AS342	92.66	101.96	1.93
BRON-AS223	41.83	47.83	1.27	BRON-AS271	235.41	241.41	1.27	BRON-AS343	95.83	105.13	1.93
BRON-AS224	45.01	51.01	1.27	BRON-AS272	241.76	247.76	1.27	BRON-AS344	99.01	108.31	1.93
BRON-AS225	48.18	54.18	1.27	BRON-AS273	248.11	254.11	1.27	BRON-AS345	102.31	111.61	1.93
BRON-AS226	51.36	57.36	1.27	BRON-AS274	254.46	260.46	1.27	BRON-AS346	105.49	114.79	1.93
BRON-AS227	54.53	60.53	1.27	BRON-AS275	267.16	273.16	1.27	BRON-AS347	108.66	117.96	1.93
BRON-AS228	57.71	63.71	1.27	BRON-AS276	279.86	285.86	1.27	BRON-AS348	111.84	121.14	1.93
BRON-AS229	60.88	66.88	1.27	BRON-AS277	292.56	298.56	1.27	BRON-AS349	115.01	124.31	1.93
BRON-AS230	64.06	70.06	1.27	BRON-AS278	305.26	311.26	1.27	BRON-AS350	118.19	127.49	1.93
BRON-AS231	66.83	72.83	1.27	BRON-AS279	330.66	336.66	1.27	BRON-AS351	121.36	130.66	1.93
BRON-AS232	70	76	1.27	BRON-AS280	356.06	362.06	1.27	BRON-AS352	124.54	133.84	1.93
BRON-AS233	73.18	79.18	1.27	BRON-AS281	381.46	387.46	1.27	BRON-AS353	127.71	137.01	1.93
BRON-AS234	76.35	82.35	1.27	BRON-AS282	406.12	412.12	1.27	BRON-AS354	130.89	140.19	1.93
BRON-AS235	79.53	85.53	1.27	BRON-AS283	431.52	437.52	1.27	BRON-AS355	134.06	143.36	1.93
BRON-AS236	82.7	88.7	1.27	BRON-AS284	456.92	462.92	1.27	BRON-AS356	137.24	146.54	1.93
BRON-AS237	85.88	91.88	1.27	BRON-AS309	11.43	20.73	1.93	BRON-AS357	140.41	149.71	1.93
BRON-AS238	89.05	95.05	1.27	BRON-AS310	13.03	22.33	1.93	BRON-AS358	143.59	152.89	1.93
BRON-AS239	92.23	98.23	1.27	BRON-AS311	14.61	23.91	1.93	BRON-AS359	146.76	156.06	1.93
BRON-AS240	95.4	101.4	1.27	BRON-AS312	16.21	25.51	1.93	BRON-AS360	149.94	159.24	1.93
BRON-AS241	98.58	104.58	1.27	BRON-AS313	17.78	27.08	1.93	BRON-AS361	153.11	162.41	1.93
BRON-AS242	101.75	107.75	1.27	BRON-AS314	19.38	28.68	1.93	BRON-AS362	159.46	168.76	1.93
BRON-AS243	104.93	110.93	1.27	BRON-AS315	20.96	30.26	1.93	BRON-AS363	165.81	175.11	1.93
BRON-AS244	108.1	114.1	1.27	BRON-AS316	22.56	31.86	1.93	BRON-AS364	172.16	181.46	1.93
BRON-AS245	111.28	117.28	1.27	BRON-AS317	24.13	33.43	1.93	BRON-AS365	178.51	187.81	1.93
BRON-AS246	114.45	120.45	1.27	BRON-AS318	25.73	35.03	1.93	BRON-AS366	184.86	194.16	1.93
BRON-AS247	117.63	123.63	1.27	BRON-AS319	27.31	36.61	1.93	BRON-AS367	191.21	200.51	1.93
BRON-AS248	121.11	127.11	1.27	BRON-AS320	28.91	38.21	1.93	BRON-AS368	197.56	206.86	1.93
BRON-AS249	124.28	130.28	1.27	BRON-AS321	30.48	39.78	1.93	BRON-AS369	203.91	213.21	1.93
BRON-AS250	127.46	133.46	1.27	BRON-AS322	32.08	41.38	1.93	BRON-AS370	210.26	219.56	1.93
BRON-AS251	130.63	136.63	1.27	BRON-AS323	33.43	42.73	1.93	BRON-AS371	216.61	225.91	1.93
BRON-AS252	133.81	139.81	1.27	BRON-AS324	35.26	44.56	1.93	BRON-AS372	222.96	232.26	1.93
BRON-AS253	136.98	142.98	1.27	BRON-AS325	38.43	47.73	1.93	BRON-AS373	229.31	238.61	1.93
BRON-AS254	140.16	146.16	1.27	BRON-AS326	41.61	50.91	1.93	BRON-AS374	235.66	244.96	1.93
BRON-AS255	143.33	149.33	1.27	BRON-AS327	44.78	54.08	1.93	BRON-AS375	242.01	251.31	1.93
BRON-AS256	146.51	152.51	1.27	BRON-AS328	47.96	57.26	1.93	BRON-AS376	248.36	257.66	1.93
BRON-AS257	149.68	155.68	1.27	BRON-AS329	51.13	60.43	1.93	BRON-AS377	254.71	264.01	1.93
BRON-AS258	152.86	158.86	1.27	BRON-AS330	54.31	63.61	1.93	BRON-AS378	267.41	276.71	1.93
BRON-AS259	159.21	165.21	1.27	BRON-AS331	57.61	66.91	1.93	BRON-AS379	280.11	289.41	1.93

# BRON (574)

## 承托环 BACK-UP RING

编号 Part No	内径 ød	外径 øD	高度 h		编号 Part No	内径 ød	外径 øD	高度 h		编号 Part No	内径 ød	外径 øD	高度 h
BRON-AS380	292.81	302.11	1.93										
BRON-AS381	305.51	314.81	1.93										
BRON-AS382	330.91	340.21	1.93										
BRON-AS383	356.31	365.61	1.93										
BRON-AS384	381.71	391.01	1.93										
BRON-AS385	406.6	415.9	1.93										
BRON-AS386	432	441.3	1.93										
BRON-AS387	457.4	466.7	1.93										
BRON-AS388	482.75	492.05	1.93										
BRON-AS389	508.15	517.45	1.93										
BRON-AS390	533.55	542.85	1.93										
BRON-AS391	558.95	568.25	1.93										
BRON-AS392	584.02	593.32	1.93										
BRON-AS393	609.42	618.72	1.93										
BRON-AS394	634.82	644.12	1.93										
BRON-AS395	660.22	669.52	1.93										
BRON-AS425	115.6	127.58	2.97										
BRON-AS426	118.77	130.75	2.97										
BRON-AS427	121.95	133.93	2.97										
BRON-AS428	125.12	137.1	2.97										
BRON-AS429	128.3	140.28	2.97										
BRON-AS430	131.47	143.45	2.97										
BRON-AS431	134.65	146.63	2.97										
BRON-AS432	137.82	149.8	2.97										
BRON-AS433	141	152.98	2.97										
BRON-AS434	144.17	156.15	2.97										
BRON-AS435	147.35	159.33	2.97										
BRON-AS436	150.52	162.5	2.97										
BRON-AS437	153.7	165.68	2.97										
BRON-AS438	159.36	171.34	2.97										
BRON-AS439	165.71	177.69	2.97										
BRON-AS440	172.06	184.04	2.97										
BRON-AS441	178.41	190.39	2.97										
BRON-AS442	184.76	196.74	2.97										
BRON-AS443	191.11	203.09	2.97										
BRON-AS444	197.46	209.44	2.97										
BRON-AS445	203.81	215.79	2.97										
BRON-AS446	216.51	228.49	2.97										
BRON-AS447	229.21	241.19	2.97										
BRON-AS448	241.91	253.89	2.97										
BRON-AS449	254.61	266.59	2.97										
BRON-AS450	267.31	279.29	2.97										
BRON-AS451	280.01	291.99	2.97										
BRON-AS452	292.71	304.69	2.97										
BRON-AS453	305.41	317.39	2.97										

DU

活塞杆密封  
ROD SEAL

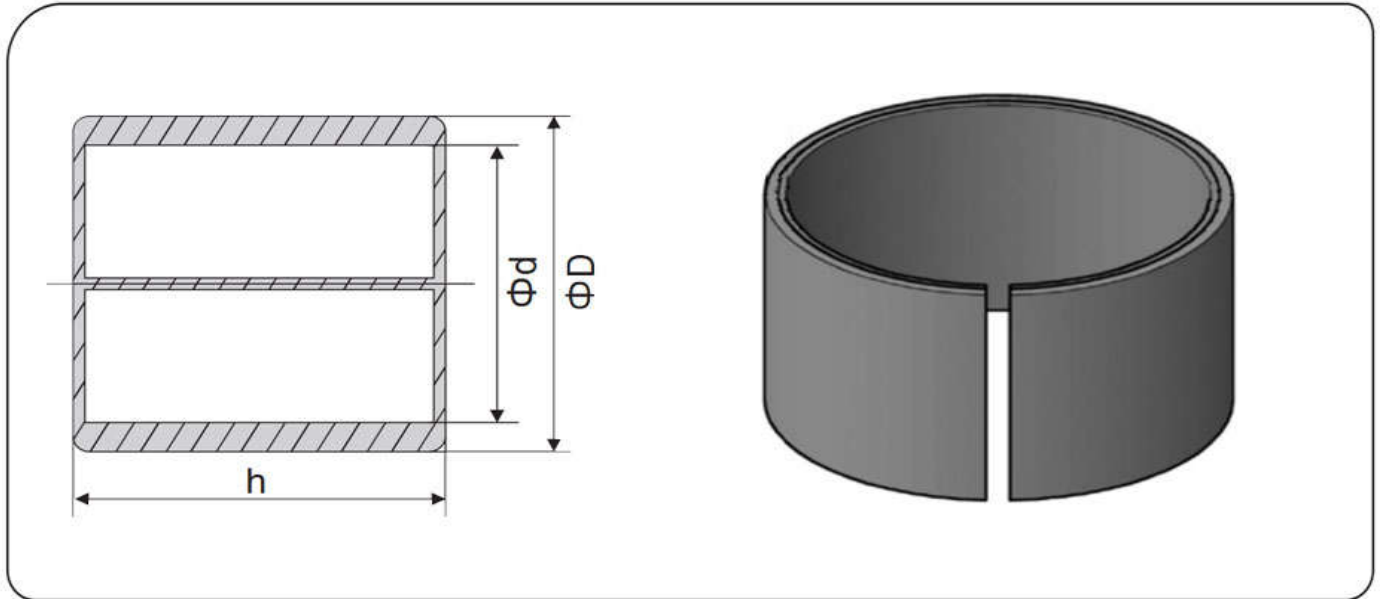

编号 Part No.	内径 ød	外径 øD	高度 h
DU 20*20	20	23	20
DU 25*20	25	28	20
DU 30*20	30	34	20
DU 30*25	30	34	25
DU 35*25	35	39	25
DU 40*20	40	44	20
DU 40*25	40	44	25
DU 40*30	40	44	30
DU 45*20	45	50	20
DU 45*30	45	50	30
DU 45*40	45	50	40
DU 50*20	50	55	20
DU 50*25	50	55	25
DU 50*30	50	55	30
DU 50*35	50	55	35
DU 50*40	50	55	40
DU 55*30	55	60	30
DU 55*35	55	60	35
DU 55*40	55	60	40
DU 60*30	60	65	30
DU 60*35	60	65	35
DU 60*40	60	65	40
DU 60*60	60	65	60
DU 65*30	65	70	30
DU 65*35	65	70	35
DU 65*40	65	70	40
DU 70*15	70	75	15
DU 70*30	70	75	30
DU 70*35	70	75	35
DU 70*40	70	75	40

编号 Part No.	内径 ød	外径 øD	高度 h
DU 70*45	70	75	45
DU 75*30	75	80	30
DU 75*35	75	80	35
DU 75*40	75	80	40
DU 75*60	75	80	60
DU 80*15	80	85	15
DU 80*30	80	85	30
DU 80*35	80	85	35
DU 80*40	80	85	40
DU 80*50	80	85	50
DU 80*60	80	85	60
DU 85*30	85	90	30
DU 85*35	85	90	35
DU 85*40	85	90	40
DU 85*50	85	90	50
DU 85*60	85	90	60
DU 90*20	90	95	20
DU 90*30	90	95	30
DU 90*35	90	95	35
DU 90*40	90	95	40
DU 90*45	90	95	45
DU 90*50	90	95	50
DU 90*60	90	95	60
DU 95*30	95	100	30
DU 95*35	95	100	35
DU 95*40	95	100	40
DU 95*45	95	100	45
DU 95*50	95	100	50
DU 95*60	95	100	60
DU 100*20	100	105	20





# DRN

## D型圈

### D-RING SEAL

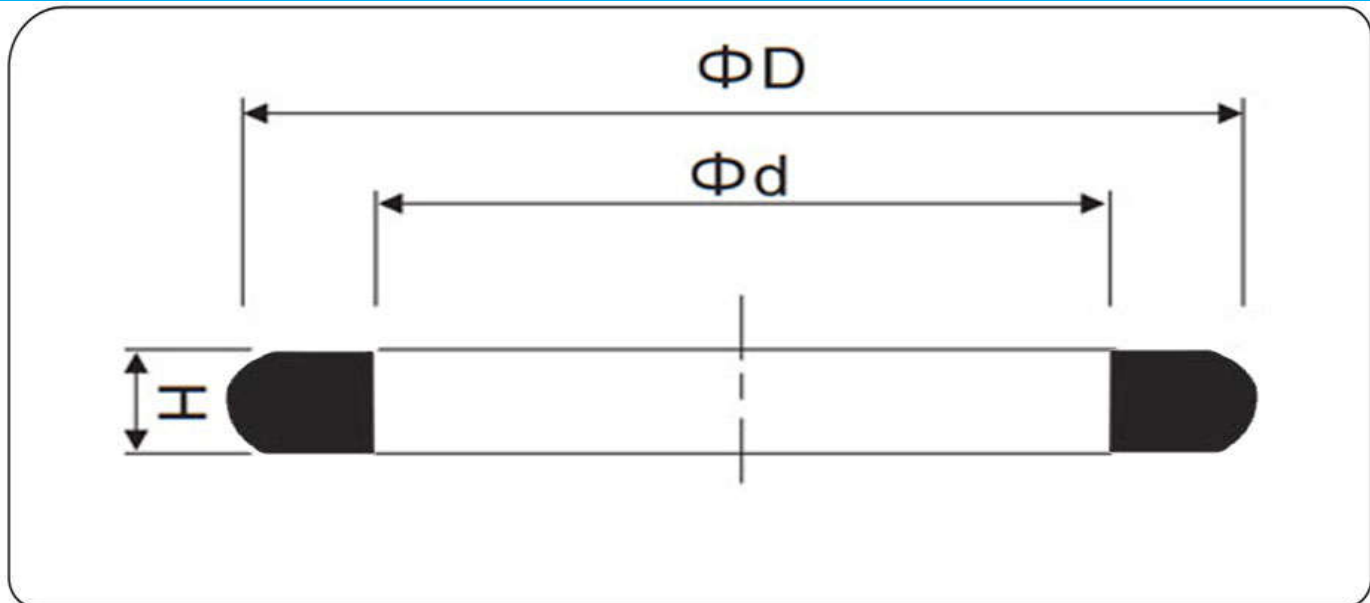

编号 Part No.	内径 $\phi d$	外径 $\phi D$	高度 H
DRN 133.5*148.9*4	133.5	148.9	4
DRN 148.7*164.1*4	148.7	164.1	4
DRN 166.3*181.7*4	166.3	181.7	4
DRN 170*185.4*4	170	185.4	4
DRN 187*202.4*4	187	202.4	4
DRN 196.7*211.7*4	196.7	211.7	4
DRN 367*384*5	367	384	5
DRN 406*423*5	406	423	5

编号 Part No.	内径 $\phi d$	外径 $\phi D$	高度 H

# DRP

## D型圈

## D-RING SEAL

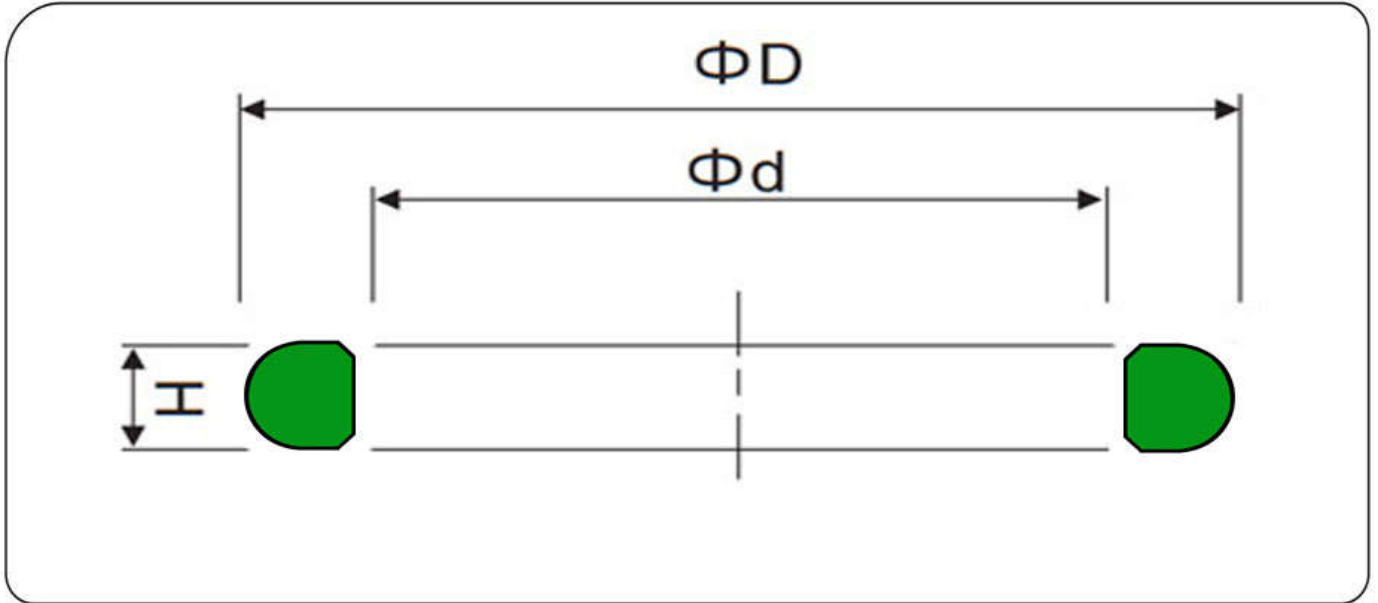

编号 Part No.	内径 $\phi d$	外径 $\phi D$	高度 H
DRP 160*169*3.1	160	169	3.1
DRP 171*180*3.1	171	180	3.1
DRP 180*189*3.1	180	189	3.1
DRP 156*165*3.53	156	165	3.53
DRP 176*185*3.53	176	185	3.53
DRP 187*194.6*3.53	187	194.6	3.53
DRP 200.5*207.7*3.53	200.5	207.7	3.53
DRP 216.2*223.4*3.53	216.2	223.4	3.53
DRP 115*125*4.3	115	125	4.3
DRP 120*130*4.3	120	130	4.3
DRP 130*140*4.3	130	140	4.3
DRP 185*192.2*5	185	192.2	5
DRP 202*209.2*5	202	209.2	5
DRP 214.5*221.7*5	214.5	221.7	5
DRP 233.9*241.1*5	233.9	241.1	5
DRP 70*80*5.7	70	80	5.7
DRP 90*100*5.7	90	100	5.7
DRP 110*120*5.7	110	120	5.7
DRP 120*130*5.7	120	130	5.7
DRP 125*135*5.7	125	135	5.7
DRP 148*158*5.7	148	158	5.7
DRP 160*171*6.7	160	171	6.7
DRP 191*202*6.7	191	202	6.7
DRP 211*222*6.7	211	222	6.7
DRP 164*174*9.8	164	174	9.8

编号 Part No.	内径 $\phi d$	外径 $\phi D$	高度 H

# VA

## 旋转密封

### ROTARY SHAFT SEAL

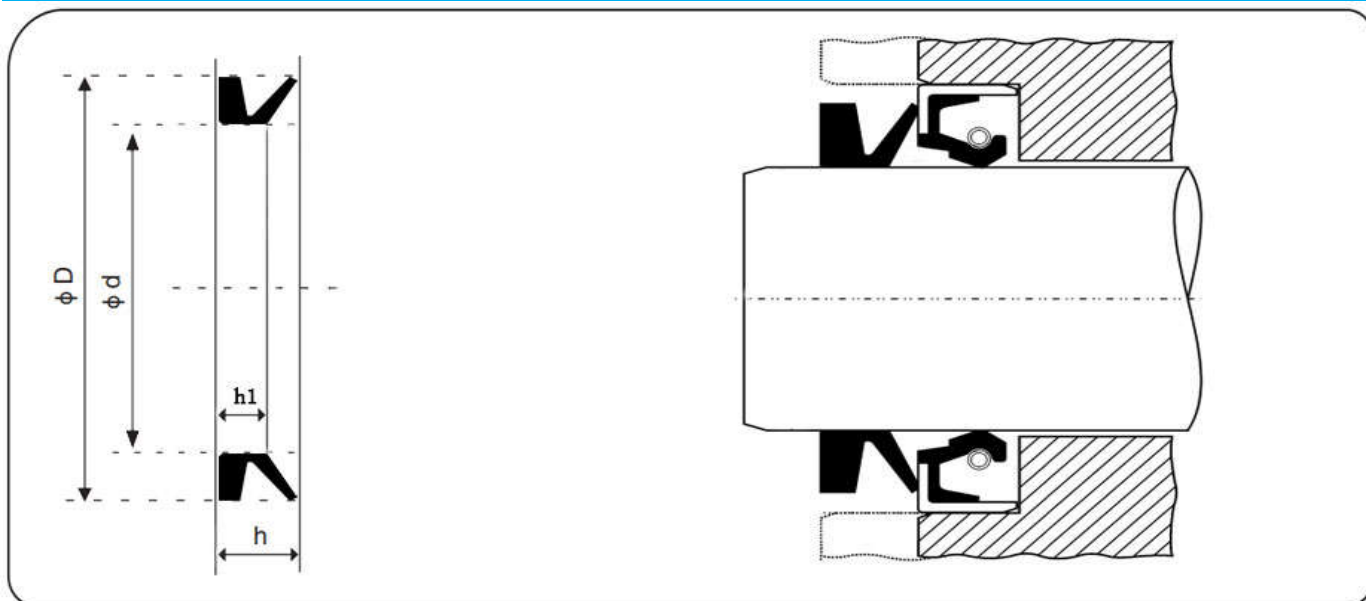

编号 Part No.	内径 ød	外径 øD	高度 h1	高度 h
VA 60	52	44	6.8	11
VA 65	57	59	6.8	11
VA 70	62	74	6.8	11
VA 75	67	89	6.8	11
VA 80	72	84	6.8	11
VA 85	76	88	6.8	11
VA 90	80	92	6.8	11
VA 95	85	97	6.8	11
VA 100	90	102	6.8	11
VA 105	96	109	7.9	12.8
VA 110	99	113	7.9	12.8
VA 115	102	117	7.9	12.8
VA 120	108	122	7.9	12.8
VA 130	117	131	7.9	12.8

编号 Part No.	内径 ød	外径 øD	高度 h1	高度 h

# VAY

## 销边防尘密封

### PIN DUST WIPER SEAL

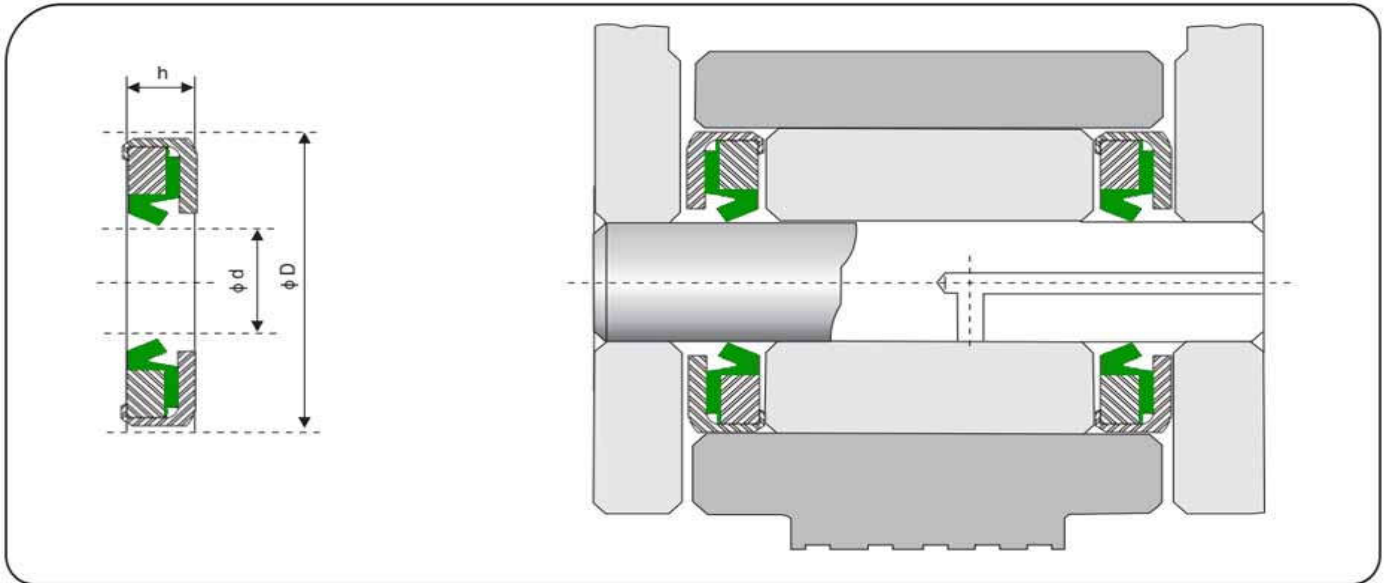

编号 Part No.	内径 ød	外径 øD	高度 h
VAY 35*45*4	35	45	4
VAY 40*50*4	40	50	4
VAY 45*55*4	45	55	4
VAY 45*55*6	45	55	6
VAY 45*55*8	45	55	8
VAY 45*60*4	45	60	4
VAY 45*60*8	45	60	8
VAY 50*60*4	50	60	4
VAY 50*60*6	50	60	6
VAY 50*60*8	50	60	8
VAY 50*65*4	50	65	4
VAY 50*65*8	50	65	8
VAY 55*65*4	55	65	4
VAY 55*65*8	55	65	8
VAY 55*70*4	55	70	4
VAY 55*70*8	55	70	8
VAY 60*75*4	60	75	4
VAY 60*75*8	60	75	8
VAY 65*80*4	65	80	4
VAY 65*80*8	65	80	8
VAY 70*80*4	70	80	4
VAY 70*85*4	70	85	4
VAY 70*85*5	70	85	5
VAY 70*85*8	70	85	8
VAY 75*90*4	75	90	4
VAY 75*90*8	75	90	8
VAY 80*90*4	80	90	4
VAY 80*90*8	80	90	8
VAY 80*95*4	80	95	4
VAY 80*95*8	80	95	8
VAY 80*100*4	80	100	4
VAY 80*100*8	80	100	8
VAY 85*100*4	85	100	4
VAY 85*100*6	85	100	6

编号 Part No.	内径 ød	外径 øD	高度 h
VAY 85*100*8	85	100	8
VAY 90*105*4	90	105	4
VAY 90*105*6	90	105	6
VAY 90*105*8	90	105	8
VAY 90*110*4	90	110	4
VAY 90*110*8	90	110	8
VAY 95*110*4	95	110	4
VAY 95*110*6	95	110	6
VAY 95*110*8	95	110	8
VAY 100*115*4	100	115	4
VAY 100*115*6	100	115	6
VAY 100*115*7	100	115	7
VAY 100*115*8	100	115	8
VAY 100*120*4	100	120	4
VAY 100*120*8	100	120	8
VAY 105*120*4	105	120	4
VAY 105*120*8	105	120	8
VAY 110*125*4	110	125	4
VAY 110*125*8	110	125	8
VAY 110*130*4	110	130	4
VAY 110*130*8	110	130	8
VAY 110*135*8	110	135	8
VAY 115*130*4	115	130	4
VAY 115*130*8	115	130	8
VAY 120*135*8	120	135	8
VAY 120*140*4	120	140	4
VAY 120*140*8	120	140	8
VAY 125*140*4	125	140	4
VAY 125*140*8	125	140	8
VAY 130*145*8	130	145	8
VAY 140*160*8	140	160	8
VAY 160*180*5	160	180	5
VAY 200*220*8	200	220	8

# OIL SEAL

## 骨架油封

## OIL SEAL

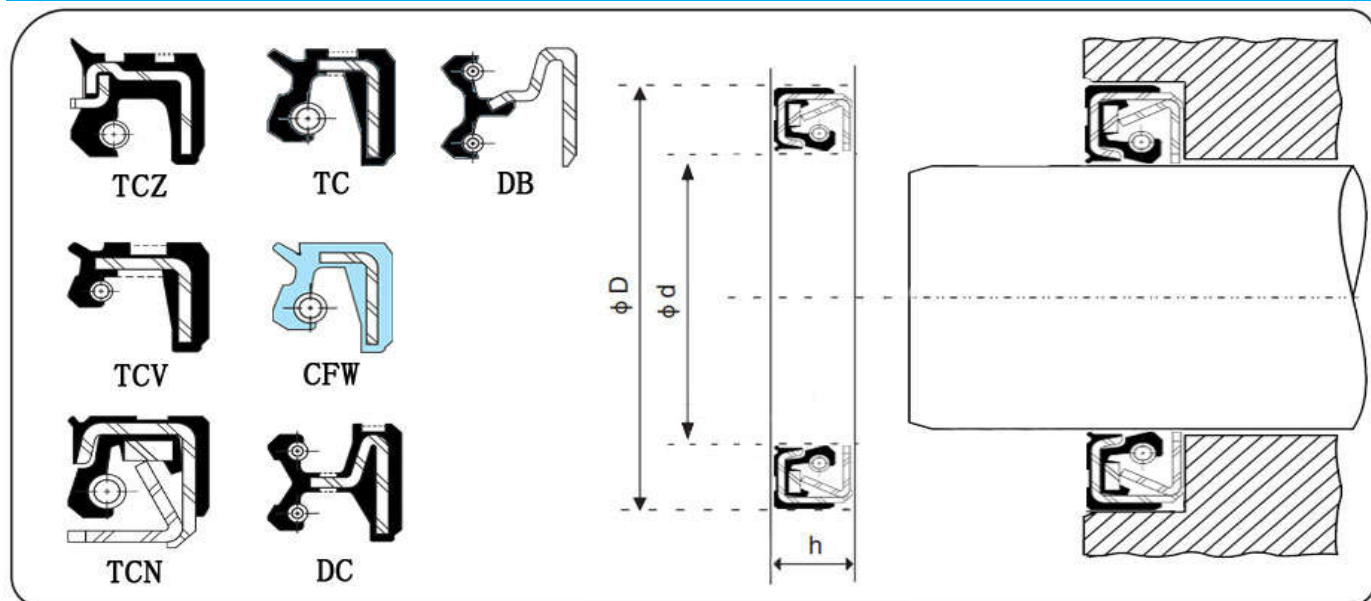

编号 Part No.	系列	内径 ød	外径 øD	高度 h
AP0875	TCN	19	35	8
AP1033	TCN	20	40	11
AP1147	TCN	22	42	10
AP1148	TCN	22	42	11
AP1338F	TCN	25	45	11
AP1563J	TCN	28	48	11
AP1709H	TCN	30	50	11
AP1904F	TCN	32	52	11
AP1978G	TCN	34	54	11
AP2083	TCN	35	55	9
AP2085G	TCN	35	55	11
AP2086	TCN	35	55	12
AP2240G	TCN	38	58	11
AP2379	TCN	40	60	12
AP2388E	TCN	40	62	11
AP2390	TCN	40	62	12
AP2507H	TCN	42	65	12
AP2659	TCN	45	65	12
AP2666	TCN	45	68	9
AP2668G	TCN	45	68	12
AP2791G	TCN	48	70	12
TCN 50*72*9	TCN	50	72	9
AP2864I	TCN	50	72	12
AP2965	TCN	52	75	9
AP2967	TCN	52	75	12
TCN 55*78*9	TCN	55	78	9
AP3055F	TCN	55	78	12
AP3154	TCN	58	80	12
TCN 60*80*12	TCN	60	80	12
AP3222B	TCN	60	82	12

编号 Part No.	系列	内径 ød	外径 øD	高度 h
AP3297G	TCN	62	85	12
AP3409F	TCN	65	90	13
AP3461	TCN	68	90	14
AP3527B	TCN	70	95	13
BP0494	TCN	72	95	13
BP2777	TCN	75	95	11
AP3618G	TCN	75	100	13
AP3744K	TCN	80	105	13
AP3842H	TCN	85	110	13
AP3932B	TCN	90	115	13
AP3994B	TCN	95	120	13
AP4063B	TCN	100	125	13
AP4153H	TCN	105	135	14
AP4212B	TCN	110	140	14
AP4282G	TCN	115	145	14
AP4346B	TCN	120	150	14
AP4399E	TCN	125	155	14
AP4451G	TCN	130	160	14
AP4498G	TCN	135	165	14
AP4542F	TCN	140	170	14
AP4581	TCN	145	175	14
AP4624G	TCN	150	180	14
AP4713	TCN	160	190	16
AP4795F	TCN	170	200	16
BP3054G	TCNT	65	90	12
BP4561	TCNH	35	60	15
AP0382	TCV	14	25	7
AP0598A	TCV	15	30	7
AP0743	TCV	17	30	7

# OIL SEAL

## 骨架油封

## OIL SEAL

编号 Part No	系列	内径 ød	外径 øD	高度 h
BP1518E	TCV	17	30	8
AP0751	TCV	17	32	8
AP0760E	TCV	17	35	8
AP0997E	TCV	20	32	8
AP1260E	TCV	24	40	8
AP1563K	TCV	28	48	11
AP1665E	TCV	30	42	7
AP2085A	TCV	35	55	11
AP1978F	TCV	34	54	11
AP2240A	TCV	38	58	11
AP2388A	TCV	40	62	11
AP2651G	TCV	45	62	9
AP2668A	TCV	45	68	12
AP2775G	TCV	48	62	9
AP8738E	TCV	50	72	7
TCV 55*78*8	TCV	55	78	8
AP3055A	TCV	55	78	12
AP3154E	TCV	58	80	12
AP3222A	TCV	60	82	12
AP3297A	TCV	62	85	12
TCV 65*90*13	TCV	65	90	13
AP3527A	TCV	70	95	13
AP1336F	TCZ	25	45	9
AP2083F	TCZ	35	55	9
AP2861G	TCZ	50	72	9
AP3053F	TCZ	55	78	9
CFW 18*35*6	CFW	18	35	6
CFW 18*35*7	CFW	18	35	7
CFW 18*35*8	CFW	18	35	8
CFW 22*35*6	CFW	22	35	6
CFW 22*42*10	CFW	22	42	10
CFW 24*42*10	CFW	24	42	10
CFW 25*35*6	CFW	25	35	6
CFW 25*37*6	CFW	25	37	6
CFW 25*38*7	CFW	25	38	7
CFW 25*40*6	CFW	25	40	6
CFW 25*40*10	CFW	25	40	10
CFW 25*42*6	CFW	25	42	6
CFW 25*42*10	CFW	25	42	10
CFW 25*47*6	CFW	25	47	6
CFW 28*40*6	CFW	28	40	6
CFW 28*40*8	CFW	28	40	8
CFW 28*42*6	CFW	28	42	6
CFW 30*40*7	CFW	30	40	7
CFW 30*42*6	CFW	30	42	6
CFW 30*50*7	CFW	30	50	7
CFW 30*50*10	CFW	30	50	10

编号 Part No	系列	内径 ød	外径 øD	高度 h
CFW 30*52*7	CFW	30	52	7
CFW 30*52*10	CFW	30	52	10
CFW 32*42*6	CFW	32	42	6
CFW 32*47*6	CFW	32	47	6
CFW 32*52*6	CFW	32	52	6
CFW 32*53*7	CFW	32	53	7
CFW 35*52*6	CFW	35	52	6
CFW 35*52*10	CFW	35	52	10
CFW 35*54*6	CFW	35	54	6
CFW 35*55*7	CFW	35	55	7
CFW 35*55*10	CFW	35	55	10
CFW 35*56*6	CFW	35	56	6
CFW 35*60*10	CFW	35	60	10
CFW 40*55*6	CFW	40	55	6
CFW 40*62*6	CFW	40	62	6
CFW 42*62*6	CFW	42	62	6
CFW 42*62*7	CFW	42	62	7
CFW 44.5*63.5*7.95	CFW	44.5	63.5	7.95
CFW 45*60*7	CFW	45	60	7
CFW 45*62*7	CFW	45	62	7
CFW 45*65*7	CFW	45	65	7
CFW 45*65*8	CFW	45	65	8
CFW 45*70*7	CFW	45	70	7
CFW 45*80*7	CFW	45	80	7
CFW 45*80*8	CFW	45	80	8
CFW 47.5*63.5*7.95	CFW	47.5	63.5	7.95
CFW 50*70*7	CFW	50	70	7
CFW 50*70*10	CFW	50	70	10
CFW 50*72*7	CFW	50	72	7
CFW 50*80*7	CFW	50	80	7
CFW 52*72*7	CFW	52	72	7
CFW 55*70*7	CFW	55	70	7
CFW 55*72*7	CFW	55	72	7
CFW 55*75*7	CFW	55	75	7
CFW 55*78*8	CFW	55	78	8
CFW 55*80*10	CFW	55	80	10
CFW 57.15*76.2*9.5	CFW	57.15	76.2	9.5
CFW 60*75*8	CFW	60	75	8
CFW 60*80*7	CFW	60	80	7
CFW 60*80*10	CFW	60	80	10
CFW 62*85*7	CFW	62	85	7
CFW 65*90*7	CFW	65	90	7
CFW 65*105*10	CFW	65	105	10
CFW 70*90*7	CFW	70	90	7
CFW 140*160*8	CFW	140	160	8
CFW 165*190*13	CFW	165	190	13
AW2086	DC	35	55	12
AW2240	DC	38	58	11

# OIL SEAL

## 骨架油封

## OIL SEAL

编号 Part No	系列	内径 ød	外径 øD	高度 h
AW2388	DC	40	62	11
AW2390	DC	40	62	12
AW2506	DC	42	68	12
AW2668	DC	45	68	12
AW2864	DC	50	72	12
AW3055	DC	55	78	12
AW3222	DC	60	82	12
AW4063	DC	100	125	13
AW4453	DC	130	165	17
AW3747	DB	80	105	20
BW4068	DB	100	125	20
DB 110*140*22	DB	110	140	22
BW4680	DB	122	152	21
AW4401	DB	125	155	22
BW0760	DBN	125	155	18
BW1748	DB	140	170	22
BW4545	DB	140	170	20
BW5668	OilSeal	140	170	17
BW5669	DB	140	170	18
BW5602	DBN	150	180	18
BW5073	DB	160	190	23
BW4528	DB	160	195	21
BW4815	OilSeal	185	245	27
BW4526	DB	190	225	21
AW5054	DB	200	230	15
BW5180	DB	200	235	22
BW5180	DB	200	235	26
BW6659	DB	230	260	21
BW4527	DB	232	267	21
BW4815	DB	245	285	27
BW5856	OilSeal	252	287	21
AD3527	TB	70	95	13
AD3618	TB	75	100	13
AD3744	TB	80	105	13
AD3842	TB	85	110	13
AD3932	TB	90	115	13
AD3994	TB	95	120	13
AD4063	TB	100	125	13
AD4153	TB	105	135	14
AD4212	TB	110	140	14
AD4282	TB	115	145	14
AD4346	TB	120	150	14
AD4399	TB	125	155	14
AD4451	TB	130	160	14
AD4542	TB	140	170	14
AD4581	TB	145	175	14
AD4624	TB	150	180	14

编号 Part No	系列	内径 ød	外径 øD	高度 h
AD4713	TB	160	190	16
AD4983	TB	190	225	16
AD5061	TB	200	235	18
AD5205	TB	220	250	16
AD5346	TB	240	275	16
AD5562	TB	280	320	22
BZ5034	OilSeal	65	105	4
GJ1721	OilSeal	30	52	10
GJ1884	OilSeal	32	46	8
UP0445	OilSeal	44.45	63.5	9.525
UP0449	OilSeal	35	57	8
UP0450	OilSeal	33.5	72.5	10
XP0803	OilSeal	55	78	9/9.5
XZ0531	OilSeal	130	250	2.5/7
XZ0532	OilSeal	165	240	4/8
AA4390	OilSeal	125	140	4
AR3505	TB4	70	88	12
AR3609	TB4	75	95	10
BC5666	OilSeal	160	190	13.5
BC5667	OilSeal	140	170	12.5
BA3494	TAY	120	150	15/18
BA3366	TAY	180	210	16/18
BA3659	TAY	195	225	16/18
BA4023	TAY	230	260	16/18
TA 120*160*17	TA	120	160	17
TA 130*160*17	TA	130	160	17
15Z 25*42*10	15Z	25	42	10
15Z 80*100*10	15Z	80	100	10
15Z 90*110*10	15Z	90	110	10
15Z 120*150*17.5	15Z	120	150	17.5
15Z 140*170*17	15Z	140	170	17
15Z 150*180*15	15Z	150	180	15
15Z 155*180*15	15Z	155	180	15
15Z 160*190*16.5	15Z	160	190	16.5
15Z 190*190*24	15Z	190	190	24
15Z 180*210*16	15Z	180	210	16
15Z 200*235*18	15Z	200	235	18
15Z 200*235*22.5	15Z	200	235	22.5
15Z 210*250*19.5	15Z	210	250	19.5
19Z 80*95*6	19Z	80	95	6
VB 60*75*8	VB	60	75	8
VB 70*85*8	VB	70	85	8
VB 85*100*5.5	VB	85	100	5.5
VB 115*135*6	VB	115	135	6
VB 120*135*7	VB	120	135	7
VB 125*140*7	VB	125	140	7
VB 155*170*7	VB	155	170	7

# TBR (T-RING)

## 排销油封 VALVE SEAL

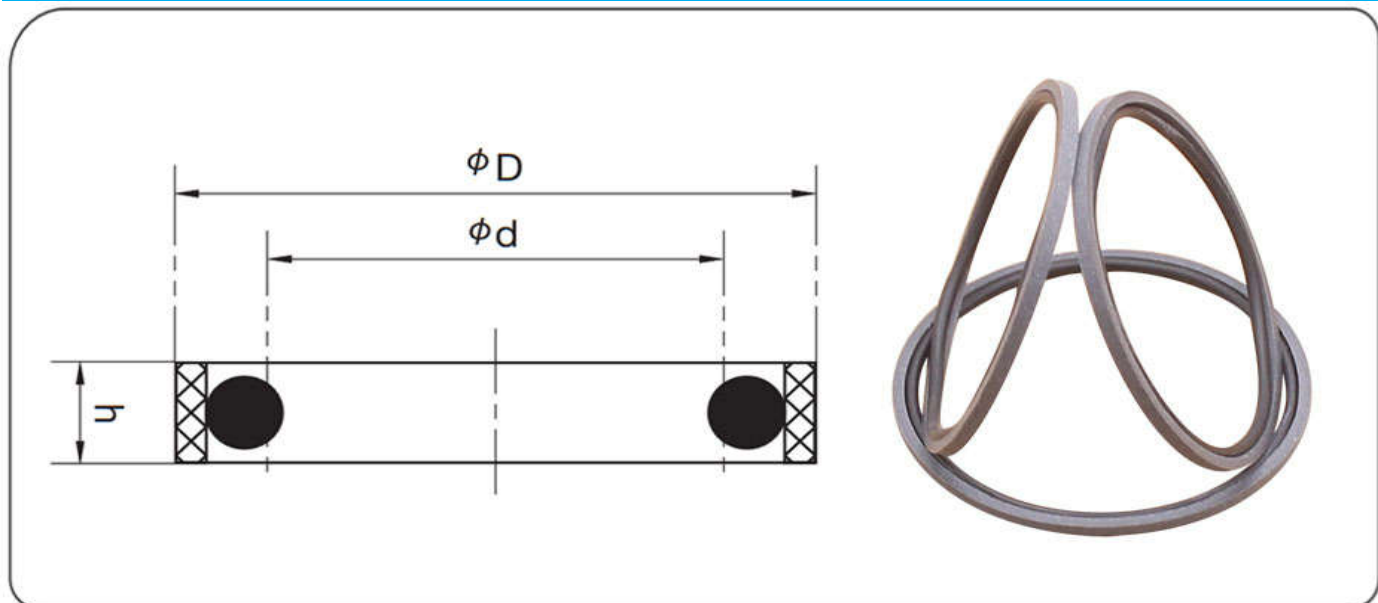

编号 Part No.	外径 $\phi D$	内径 $\phi d$	高度 h
TBR 6*2	6		2
TBR 6.5*2	6.5		2
TBR 7*2	7		2
TBR 8*2	8		2
TBR 9*2	9		2
TBR 9*1.6	9		1.6
TBR 10*2	10		2
TBR 11*2	11		2
TBR 12*2	12		2
TBR 13*2	13		2
TBR 14*2	14		2
TBR 15*2	15		2
TBR 16*2	16		2
TBR 16.2*2	16.2		2
TBR 17*1.5	17		1.5
TBR 17*2	17		2
TBR 18*2	18		2
TBR 18.5*2	18.5		2
TBR 19*2	19		2
TBR 19.5*2	19.5		2
TBR 20*2	20		2
TBR 20.4*2	20.4		2
TBR 20.5*2	20.5		2
TBR 20.6*2	20.6		2
TBR 20.8*2	20.8		2
TBR 21*2	21		2
TBR 21.5*2	21.5		2
TBR 21.6*2	21.6		2
TBR 21.8*2	21.8		2
TBR 22*2	22		2

编号 Part No.	内径 $\phi d$	外径 $\phi D$	高度 h
TBR 22.8*2	22.8		2
TBR 23*2	23		2
TBR 23.5*2	23.5		2
TBR 24*2	24		2
TBR 25*2	25		2
TBR 26*2	26		2
TBR 27*2	27		2
TBR 28*2	28		2
TBR 29*2	29		2
TBR 30*2	30		2
TBR 31*2	31		2
TBR 32*2	32		2
TBR 36*2	36		2
TBR 38*2	38		2
TBR 50*2.5	50		2.5
TBR 51*2.5	51		2.5
TBR 52*2.5	52		2.5
TBR 55*2.5	55		2.5



# VALVE SEAL

## 排销油封 VALVE SEAL



编号 Part No.	尺寸 Size	适用机型 Apply To
BR6778	SVY 12*24*7/8	702-16-51270
AR0378	SVY 12*24*2/7	PC200-1/3/5/6
BR2834	SVY 14*25*2.1/5.9	PC60-3
AR0591	SVY 15*27*1.8/7	
BR2398	SVY 16*30*2/7	
AR0874	SVY 19*35*2.3/7	PC120-5
BR3509	SVY 20*32*1.8/7	
BR3393	SVY 22*34*2.1/6.2	
AR8510	SVY 22*40*2.5/7	PC200-5
BR2511	SVY 26*44*2.5/7	PC300-5
BR3500	SVY 25*37.2*2/7	UH081, UH07-5
SX22-SVY	SVY 22*34.5*2/5.7	MS-120-8
SX22-X	X 22*28*3.5	MS-120-8
SX25-SVY	SVY 25*37.8*2/5	UH081, UH07-5
SX25-X	X 25*31*3.5	UH081, UH07-5
SX28-SVY	SVY 28*40.8*2/5	
SX28-X	X 28*34*3.5	
SX31-SVY	SVY 31*43*2/5.7	
SX31-X	X 31*37*3.5	
KYB16-NY	15.7*21.8*1.8/4	EX60
KYB16-NBR	16*22*3.2	EX60
KYB22-NY	21.8*28.2*2/5	
KYB22-NBR	21.6*29.8*5	
KYB25-NY	24.7*31.2*2.5/5.7	SK07, LS2800EJ
KYB25-NBR	24.9*32.7*4.1	SK07, LS2800EJ
KYB28-NY	27.8*33.9*2.9/5.7	UH07-7, 083, 09-7, 143
KYB28-NBR	27.6*35.4*4.5	UH07-7, 083, 09-7, 143
KYB31-NY	30.8*37.2*2.5/5.7	LS4300EJ
KYB31-NBR	30.7*38.5*4.1	LS4300EJ
UR-P21	NBR 10*14*2.3	E200B

编号 Part No.	尺寸 Size	适用机型 Apply To
MYA-10A	NBR 10*14*2.8	E320
SER-10A	NBR 10*14*3/3.9	SER-10A
UHS-10	PU 10*16*4.5	R225
LBH-10	NBR 10*17*5/6.5	ZX200S
KFY10	NBR 10*17.45*5/6.5	ZX200H
MYA-12	NBR 12*16*2.8	DH220
SER-12	NBR 12*16*2.9/3.9	SER-12
SER-12A	NBR 12*16*4.5	SER-12A
SH120	NBR 12*17*3.5	SH120
E320T	NBR 12*20*3.5/5	E320T
RUS-13	NBR 13*19*4	EX200-1U
DPKI-13	PDKB 13*19*4/4.5	EX200-1PDKB
PDU-13	NBR 13*20*5/6.5	EX200-5P
SVI 14	SVI 14*22*5.7	
PDKB 14	PDKB 14*22*4/4.5	
1P3700	1P3700	
1P3702	1P3702	
1P3703	1P3703	
1P3704	1P3704	
1P3705	1P3705	
1P3706	1P3706	
1P3707	1P3707	
1P3708	1P3708	
1P3709	1P3709	
1P3709	1P3709	

IUT

波箱垫片  
TRANSMISSION SEAL

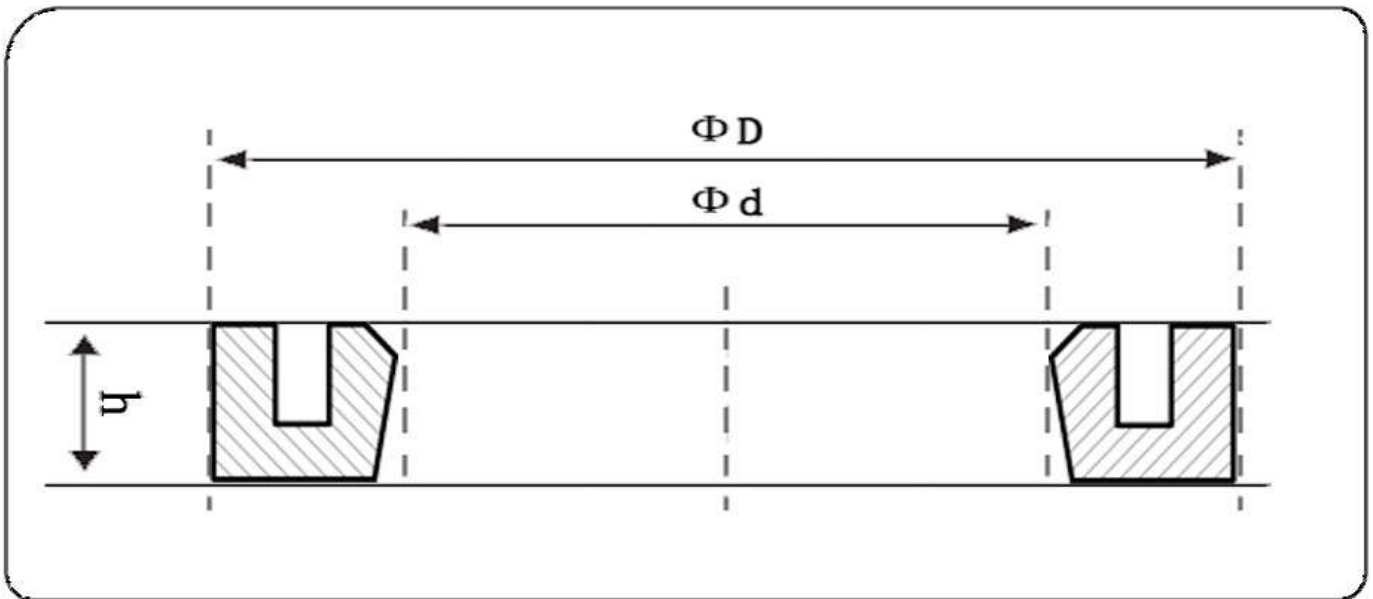

编号 Part No.	内径 $\phi d$	外径 $\phi D$	高度 h
IUT 80*86*2.8	80	86	2.8
IUT 85*92*2.8	85	92	2.8
IUT 96*104*2.8	96	104	2.8
IUT 110*116*2.8	110	116	2.8
IUT 135*141*2.8	135	141	2.8
IUT 155*161*2.8	155	161	2.8
IUT 175*181*2.8	175	181	2.8
IUT 180*186*2.8	180	186	2.8
IUT 194*200*2.8	194	200	2.8
IUT 195*201*2.8	195	201	2.8
IUT 200*206*2.8	200	206	2.8
IUT 205*211*2.8	205	211	2.8
IUT 215*221*2.8	215	221	2.8
IUT 235*241*2.8	235	241	2.8

编号 Part No.	内径 $\phi d$	外径 $\phi D$	高度 h

# OUT

## 波箱垫片

### TRANSMISSION SEAL

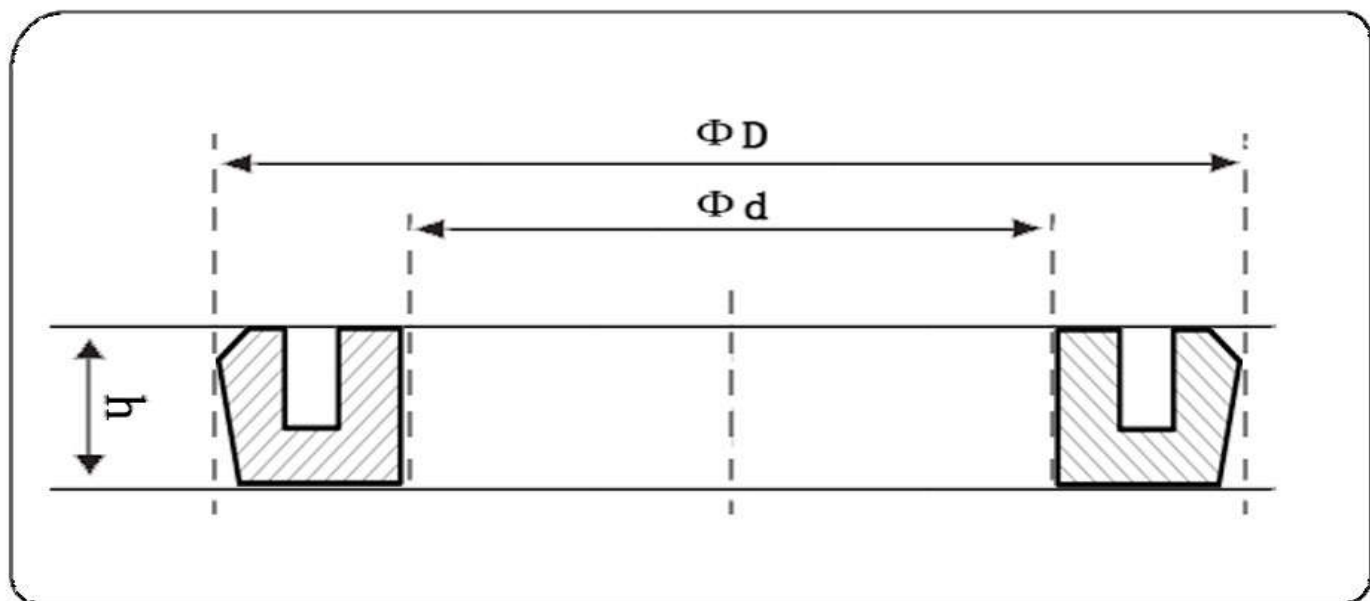

编号 Part No.	外径 øD	内径 ød	高度 h
OUT 102*96*2.8	102	96	2.8
OUT 103*97*2.8	103	97	2.8
OUT 108*102*2.8	108	102	2.8
OUT 113*107*2.8	113	107	2.8
OUT 130*123.6*2.8	130	123.6	2.8
OUT 135*129*2.8	135	129	2.8
OUT 137*131*2.8	137	131	2.8
OUT 140*134*2.8	140	134	2.8
OUT 145*139*2.8	145	139	2.8
OUT 150*144*2.8	150	144	2.8
OUT 160*153*2.8	160	153	2.8
OUT 160*154*2.8	160	154	2.8
OUT 164*158*2.8	164	158	2.8
OUT 165*159*2.8	165	159	2.8
OUT 170*164*2.8	170	164	2.8
OUT 175*169*2.8	175	169	2.8
OUT 176*170*2.8	176	170	2.8
OUT 180*174*2.8	180	174	2.8
OUT 184.5*178*2.8	184.5	178	2.8
OUT 186*180*2.8	186	180	2.8
OUT 188.6*182.2*2.8	188.6	182.2	2.8
OUT 188*182*2.8	188	182	2.8
OUT 190*184*2.8	190	184	2.8
OUT 196*190*2.8	196	190	2.8
OUT 198*192*2.8	198	192	2.8
OUT 198.8*192.4*2.8	198.8	192.4	2.8
OUT 200*194*2.8	200	194	2.8
OUT 205*199*2.8	205	199	2.8
OUT 210*203*2.8	210	203	2.8
OUT 214*208*2.8	214	208	2.8

编号 Part No.	外径 øD	内径 ød	高度 h
OUT 215*209*2.8	215	209	2.8
OUT 216*210*2.8	216	210	2.8
OUT 220*214*2.8	220	214	2.8
OUT 221*215*2.8	221	215	2.8
OUT 226*220*2.8	226	220	2.8
OUT 230*224*2.8	230	224	2.8
OUT 235*229*2.8	235	229	2.8
OUT 240*234*2.8	240	234	2.8
OUT 241*235*2.8	241	235	2.8
OUT 245*239*2.8	245	239	2.8
OUT 250*244*2.8	250	244	2.8
OUT 259.5*253*2.8	259.5	253	2.8
OUT 265*259*2.8	265	259	2.8
OUT 270*264*2.8	270	264	2.8
OUT 275*269*2.8	275	269	2.8
OUT 280*270*2.8	280	270	2.8
OUT 280*274*2.8	280	274	2.8
OUT 285*278*3.5	285	278	3.5
OUT 285*279*2.8	285	279	2.8
OUT 289*283*2.8	289	283	2.8
OUT 290*284*2.8	290	284	2.8
OUT 300*294*2.8	300	294	2.8
OUT 300*294*3.8	300	294	3.8
OUT 305*299*2.8	305	299	2.8
OUT 313.4*307*2.8	313.4	307	2.8
OUT 315*309*2.8	315	309	2.8
OUT 320*314*2.8	320	314	2.8
OUT 325*318*3.3	325	318	3.3
OUT 325*319*2.8	325	319	2.8
OUT 329*323*2.8	329	323	2.8



# STEEL RING

## 钢环

### STEEL RING

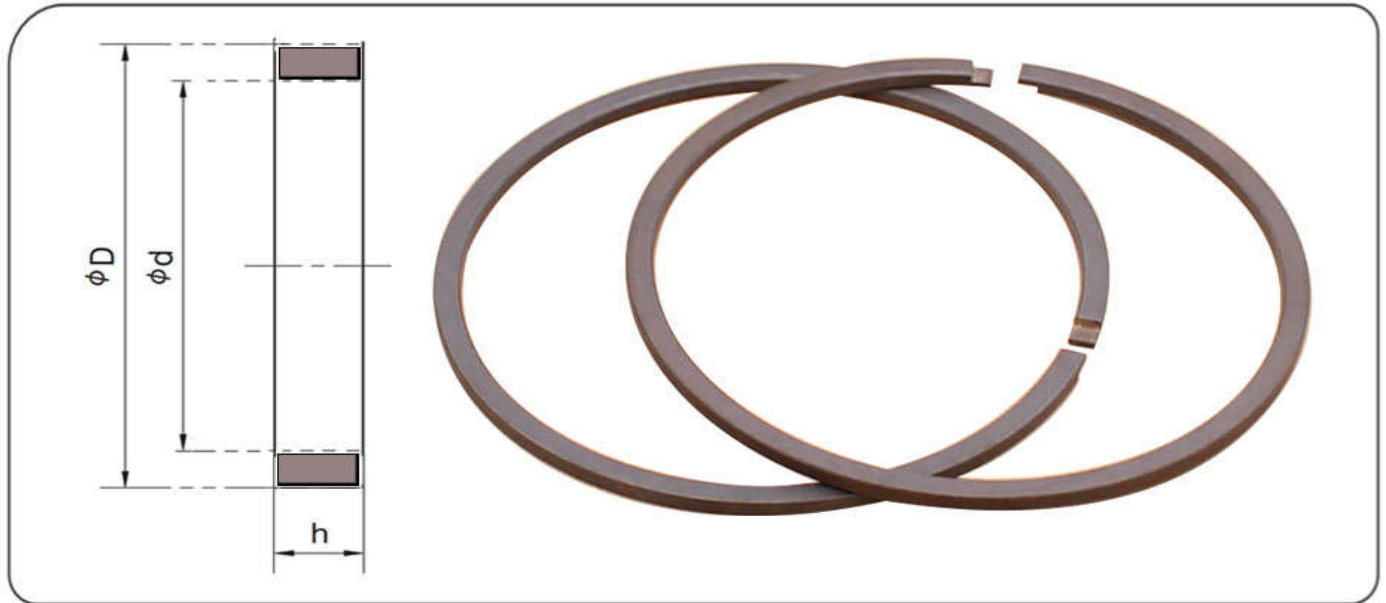

编号 Part No.	外径 øD	内径 ød	高度 h
STEEL RING 90	90	83	4
STEEL RING 95	95	87	4
STEEL RING 100	100	92	4
STEEL RING 105	105	97	4
STEEL RING 110	110	100	4
STEEL RING 115	115	105	4
STEEL RING 120	120	110	4
STEEL RING 125	125	115	4
STEEL RING 130	130	119	4
STEEL RING 135	135	124	4
STEEL RING 140	140	128	4
STEEL RING 145	145	133	4
STEEL RING 150	150	138	4
STEEL RING 160	160	148	4
STEEL RING 170	170	156	4
STEEL RING 180	180	166	4
STEEL RING 185	185	173	4
STEEL RING 200	200	184	4
STEEL RING 220	220	204	4
STEEL RING 225	225	209	4
STEEL RING 250	250	234	4

编号 Part No.	外径 øD	内径 ød	高度 h

# COPPER RING

## 铜环

### COPPER RING

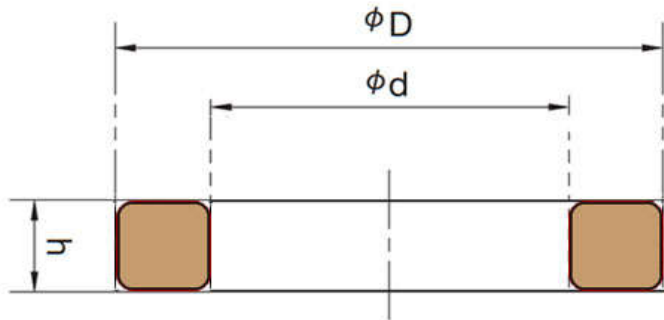

编号 Part No.	外径 øD	内径 ød	高度 h
COPPER RING 40	40	28	6
COPPER RING 45	45	33	6
COPPER RING 50	50	38	6
COPPER RING 55	55	43	6
COPPER RING 60	60	48	6
COPPER RING 65	65	53	6
COPPER RING 70	70	58	6
COPPER RING 75	75	63	6
COPPER RING 80	80	68	6
COPPER RING 85	85	73	6
COPPER RING 90	90	78	6
COPPER RING 95	95	83	6
COPPER RING 100	100	88	6
COPPER RING 105	105	93	6
COPPER RING 110	110	98	6
COPPER RING 115	115	103	6
COPPER RING 120	120	108	6
COPPER RING 125	125	113	6
COPPER RING 130	130	118	6
COPPER RING 135	135	123	6
COPPER RING 140	140	128	6
COPPER RING 145	145	133	6
COPPER RING 150	150	138	6
COPPER RING 155	155	143	6
COPPER RING 160	160	148	6
COPPER RING 165	165	153	6
COPPER RING 170	170	158	6
COPPER RING 175	175	163	6
COPPER RING 180	180	168	6
COPPER RING 185	185	173	6

编号 Part No.	外径 øD	内径 ød	高度 h
COPPER RING 190	190	178	6
COPPER RING 195	195	183	6
COPPER RING 200	200	188	6
COPPER RING 205	205	193	6
COPPER RING 210	210	198	6
COPPER RING 215	215	203	6
COPPER RING 220	220	208	6
COPPER RING 225	225	213	6
COPPER RING 230	230	218	6
COPPER RING 235	235	223	6
COPPER RING 240	240	228	6

# COUPLING

## 连接胶 COUPLING



# COUPLING

## 连接胶 COUPLING





# COUPLING

## 连接胶 COUPLING



# COUPLING

## 连接胶 COUPLING



90H



110H



140H



90H ASSY



110H ASSY



140H ASSY



160H



240H



50K



160H ASSY



240H ASSY



50K ASSY

# COUPLING

## 连接胶 COUPLING



50AM 15T



E200B/SH200  
12T



Kubota161  
17T (OD 146)



50AM 16T



E200B/SH200  
14T



S25S



S29S



SH60 15T



Yanmar13T  
(OD 146)



S32S



SH280 20T



Yanmar13T  
(OD 165)

# COUPLING

## 连接胶 COUPLING



Yanmar 15T  
(OD 146)



168\*26T



168\*50T



Yanmar 15T  
(OD 165)



168\*47T



180\*42T



198\*50T



220\*46T



260\*46T



218\*50T



248\*50T



262\*42T

## 活塞杆/活塞密封

## ROD/PISTON SEAL

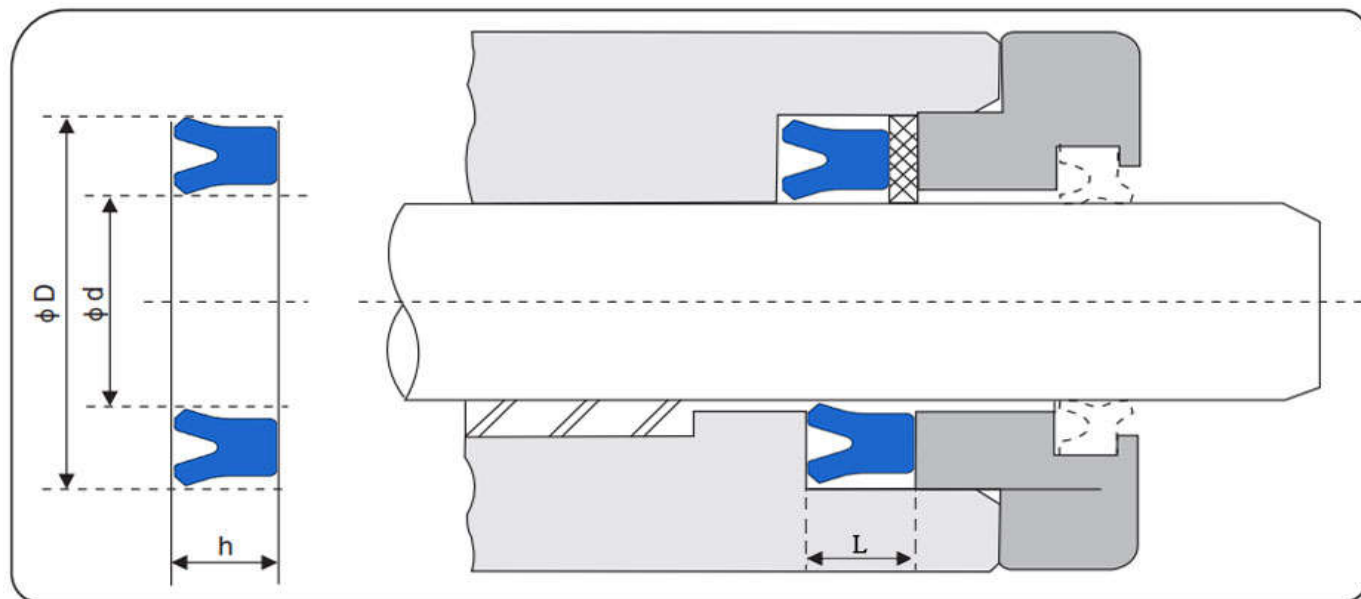

编号 Part No.	内径 ød	外径 øD	高度 h	槽宽 L
601 4.5*12.5*4.4	4.5	12.5	4.4	5
601 5*12*5.5	5	12	5.5	6.5
601 6*13*8	6	13	8	9
601 10*18*6	10	18	6	6.6
601 10*20*8	10	20	8	9
601 12*18*6	12	18	6	7
601 12*20*4.4	12	20	4.4	5
601 12*25*8	12	25	8	9
601 14*22*4.4	14	22	4.4	5
601 14*22*5	14	22	5	5.7
601 14*24*8	14	24	8	9
601 15*25*8	15	25	8	9
601 16*24*4.4	16	24	4.4	5
601 16*24*5	16	24	5	5.7
601 16*26*8	16	26	8	9
601 18*26*4.4	18	26	4.4	5
601 18*26*5	18	26	5	5.7
601 18*28*7.3	18	28	7.3	8
601 18*28*8	18	28	8	9
601 20*28*4.4	20	28	4.4	5
601 20*28*5	20	28	5	5.7
601 20*30*8	20	30	8	9
601 20*40*12	20	40	12	13
601 22*30*4.4	22	30	4.4	5
601 22*35*10	22	35	10	11
601 22*40*10	22	40	10	11
601 22.4*30*5	22.4	30	5	5.7
601 22.4*32.4*8	22.4	32.4	8	9
601 23.5*31.5*5	23.5	31.5	5	5.7
601 25*33*4.4	25	33	4.4	5

编号 Part No.	内径 ød	外径 øD	高度 h	槽宽 L
601 25*33*5	25	33	5	5.7
601 25*35*8	25	35	8	9
601 25*35*10	25	35	10	11
601 25*38*8	25	38	8	9
601 25*38*10	25	38	10	11
601 25*40*10	25	40	10	11
601 26*40*9	26	40	9	10
601 28*35.5*5	28	35.5	5	5.7
601 28*36*6.5	28	36	6.5	7.1
601 28*38*5.6	28	38	5.6	6.3
601 28*38*8	28	38	8	9
601 28*40*10	28	40	10	11
601 28*43*10	28	43	10	11
601 30*37*6	30	37	6	7
601 30*40*5.6	30	40	5.6	6.3
601 30*40*6	30	40	6	7
601 30*40*8	30	40	8	9
601 30*40*10	30	40	10	11
601 30*45*10	30	45	10	11
601 31.5*41.5*6	31.5	41.5	6	7
601 32*40*8	32	40	8	9
601 32*42*5.6	32	42	5.6	6.3
601 32*42*6	32	42	6	7
601 32*42*10	32	42	10	11
601 32*47*10	32	47	10	11
601 35*45*6	35	45	6	7
601 35*45*7	35	45	7	8
601 35*48*10	35	48	10	11
601 35*50*10	35	50	10	11
601 35.5*45*6	35.5	45	6	7

## 活塞杆/活塞密封

## ROD/PISTON SEAL

编号 Part No	内径 ød	外径 øD	高度 h	槽宽 l
601 35.5*50.5*10	35.5	50.5	10	11
601 36*46*5.6	36	46	5.6	6.3
601 38*48*6	38	48	6	7
601 38*50*9	38	50	9	10
601 38*55*9.7	38	55	9.7	11
601 38*58*9.7	38	58	9.7	11
601 40*50*5.6	40	50	5.6	6.3
601 40*50*6	40	50	6	7
601 40*50*10	40	50	10	11
601 40*55*9.9	40	55	9.9	11
601 40*55*10	40	55	10	11
601 40*60*12	40	60	12	13
601 45*53*10	45	53	10	11
601 45*55*5.6	45	55	5.6	6.3
601 45*55*6	45	55	6	7
601 45*55*10	45	55	10	11
601 45*56*7	45	56	7	8
601 45*60*10	45	60	10	11
601 45*65*10	45	65	10	11
601 46*56*6	46	56	6	7
601 48*63*10	48	63	10	11
601 50*60*5.6	50	60	5.6	6.3
601 50*60*6	50	60	6	7
601 50*60*10	50	60	10	11
601 50*65*10	50	65	10	11
601 50*70*12	50	70	12	13
601 52*62*10	52	62	10	11
601 53*63*6	53	63	6	7
601 55*65*6	55	65	6	7
601 55*75*12	55	75	12	13
601 56*66*6	56	66	6	7
601 56*71*8.4	56	71	8.4	9.5
601 56*76*12	56	76	12	13
601 60*70*6	60	70	6	7
601 60*70*10	60	70	10	11
601 60*71*7	60	71	7	8
601 60*76*12	60	76	12	13
601 60*80*12	60	80	12	13
601 63*73*6	63	73	6	7
601 63*73*11.8	63	73	11.8	13
601 63*78*8.4	63	78	8.4	9.5
601 65*75*6	65	75	6	7
601 65*80*8.4	65	80	8.4	9.5
601 65*80*12	65	80	12	13
601 65*85*12	65	85	12	13
601 70*80*6	70	80	6	7
601 70*80*11.8	70	80	11.8	13
601 70*85*8.4	70	85	8.4	9.5
601 70*85*12	70	85	12	13

编号 Part No	内径 ød	外径 øD	高度 h	槽宽 l
601 70*90*12	70	90	12	13
601 70*92*12	70	92	12	13
601 71*80*6	71	80	6	7
601 75*85*6	75	85	6	7
601 75*85*11.8	75	85	11.8	13
601 75*90*12	75	90	12	13
601 75*95*12	75	95	12	13
601 75*100*22	75	100	22	24
601 80*90*6	80	90	6	7
601 80*90*8	80	90	8	8.8
601 80*90*11.8	80	90	11.8	13
601 80*95*8.4	80	95	8.4	9.5
601 80*100*12	80	100	12	13
601 80*100*13.2	80	100	13.2	14.5
601 85*100*8.4	85	100	8.4	9.5
601 85*100*8.9	85	100	8.9	10
601 85*100*12	85	100	12	13
601 85*105*12	85	105	12	13
601 90*100*11.8	90	100	11.8	13
601 90*105*8.4	90	105	8.4	9.5
601 90*105*8.9	90	105	8.9	10
601 90*110*12	90	110	12	13
601 95*110*8.9	95	110	8.9	10
601 95*110*12	95	110	12	13
601 95*115*12	95	115	12	13
601 100*110*6.4	100	110	6.4	7
601 100*115*8.9	100	115	8.9	10
601 100*115*12	100	115	12	13
601 100*120*11	100	120	11	12.5
601 100*120*12	100	120	12	13
601 105*125*11.4	105	125	11.4	12.5
601 105*125*15	105	125	15	17
601 110*130*11	110	130	11	12.5
601 110*130*15	110	130	15	17
601 112*125*8.9	112	125	8.9	10
601 115*130*8.9	115	130	8.9	10
601 115*135*15	115	135	15	17
601 118*130*7.3	118	130	7.3	8
601 120*140*14.5	120	140	14.5	16
601 120*140*15	120	140	15	17
601 125*140*8.9	125	140	8.9	10
601 125*145*11.4	125	145	11.4	12.5
601 125*145*15	125	145	15	17
601 130*150*15	130	150	15	17
601 136*150*8.5	136	150	8.5	9.5
601 140*154*9	140	154	9	10
601 140*155*8.9	140	155	8.9	10
601 140*160*15	140	160	15	17
601 145*160*8.9	145	160	8.9	10

## 活塞杆/活塞密封

## ROD/PISTON SEAL

编号 Part No	内径 $\varnothing d$	外径 $\varnothing D$	高度 h	槽宽 l
601 145*165*15	145	165	15	17
601 150*165*8.9	150	165	8.9	10
601 150*170*15	150	170	15	17
601 153*165*7.3	153	165	7.3	8
601 155*170*8.9	155	170	8.9	10
601 155*180*15	155	180	15	17
601 160*175*9	160	175	9	10
601 160*180*15	160	180	15	16
601 160*185*15	160	185	15	17
601 165*180*9	165	180	9	10
601 165*183*10	165	183	10	11
601 165*190*15	165	190	15	17
601 170*195*15	170	195	15	17
601 175*190*8.9	175	190	8.9	10
601 175*200*15	175	200	15	17
601 180*200*12	180	200	12	13
601 180*205*15	180	205	15	17
601 190*210*12	190	210	12	13
601 190*215*15	190	215	15	17
601 200*220*12	200	220	12	13
601 200*220*15	200	220	15	16
601 200*225*15	200	225	15	17
601 210*230*15	210	230	15	16
601 210*235*18	210	235	18	20
601 220*240*12	220	240	12	13
601 220*240*15	220	240	15	16
601 220*250*17	220	250	17	19.2
601 230*250*12	230	250	12	13
601 230*250*15	230	250	15	16
601 240*260*12	240	260	12	13
601 240*260*15	240	260	15	16
601 240*265*18	240	265	18	20
601 250*275*18	250	275	18	20
601 260*280*15	260	280	15	16
601 260*290*18	260	290	18	20
601 265*295*18	265	295	18	20
601 270*290*11	270	290	11	12
601 270*300*18	270	300	18	20
601 280*300*11	280	300	11	12
601 280*310*18	280	310	18	20
601 290*320*18	290	320	18	20
601 300*330*18	300	330	18	20
601 330*350*11	330	350	11	12
601 375*405*22	375	405	22	24
601 400*425*25	400	425	25	27

编号 Part No	内径 $\varnothing d$	外径 $\varnothing D$	高度 h	槽宽 l

## 活塞杆密封 ROD SEAL

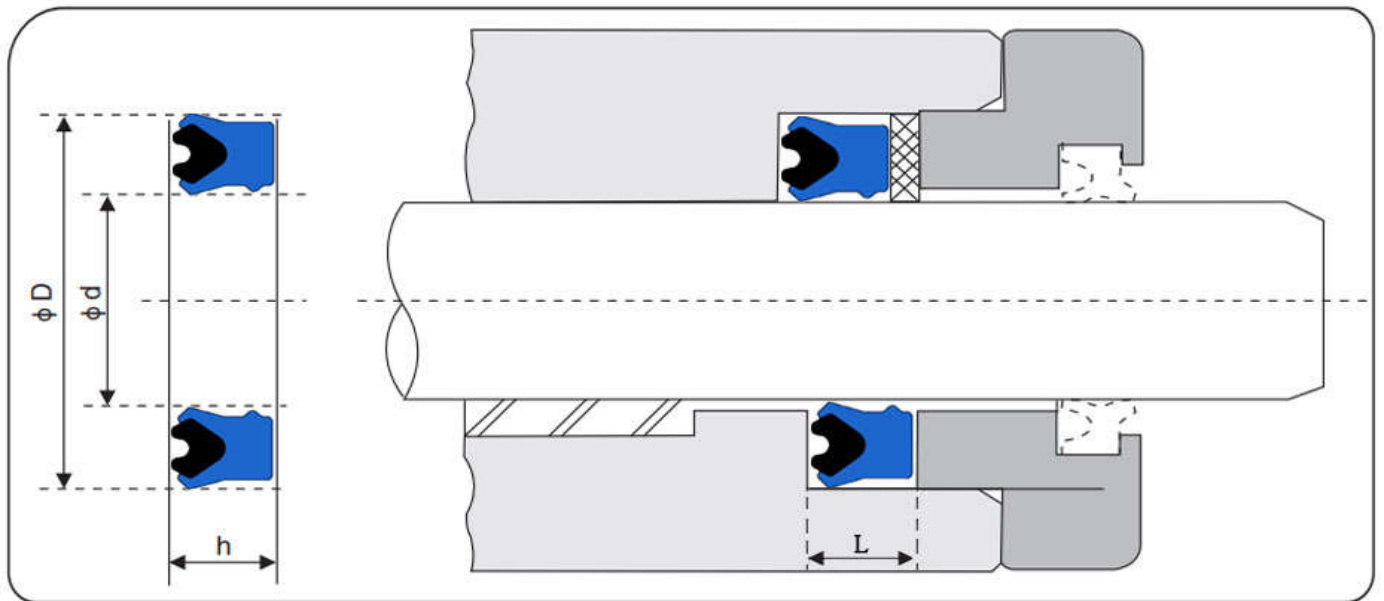

编号 Part No.	内径 ød	外径 øD	高度 h	槽宽 L
622 40*50*7	40	50	7	8
622 45*55*7	45	55	7	8
622 50*60*6	50	60	6	7
622 50*60*8	50	60	8	9
622 50*63*10	50	63	10	11
622 50*65*9	50	65	9	10
622 55*65*8	55	65	8	9
622 55*68*10	55	68	10	11
622 55*70*9	55	70	9	10
622 60*70*6	60	70	6	7
622 60*70*8	60	70	8	9
622 60*73*10	60	73	10	11
622 60*75*9	60	75	9	10
622 60*75*10	60	75	10	11
622 65*75*6	65	75	6	7
622 65*75*8	65	75	8	9
622 65*78*10	65	78	10	11
622 65*80*9	65	80	9	10
622 70*80*6	70	80	6	7
622 70*83*10	70	83	10	11
622 70*85*9	70	85	9	10
622 70*85*10	70	85	10	11
622 75*85*6	75	85	6	7
622 75*88*10	75	88	10	11
622 75*90*9	75	90	9	10
622 80*90*6	80	90	6	7
622 80*93*10	80	93	10	11
622 80*95*9	80	95	9	10
622 80*95*10	80	95	10	11
622 85*100*9	85	100	9	10

编号 Part No.	内径 ød	外径 øD	高度 h	槽宽 L
622 85*100*10	85	100	10	11
622 85*105*12	85	105	12	13
622 90*105*9	90	105	9	10
622 90*105*10	90	105	10	11
622 95*110*9	95	110	9	10
622 95*110*10	95	110	10	11
622 95*115*12	95	115	12	13
622 100*115*9	100	115	9	10
622 100*115*10	100	115	10	11
622 100*120*12	100	120	12	13
622 105*120*9	105	120	9	10
622 105*120*10	105	120	10	11
622 105*125*12	105	125	12	13
622 105*125*15	105	125	15	17
622 110*125*9	110	125	9	10
622 110*130*10	110	130	10	11
622 115*130*9	115	130	9	10
622 115*130*10	115	130	10	11
622 115*135*12	115	135	12	13
622 118*133*9	118	133	9	10
622 120*135*9	120	135	9	10
622 120*140*12	120	140	12	13
622 130*150*12	130	150	12	13
622 130*150*16	130	150	16	18
622 140*160*12	140	160	12	13
622 130*150*12	130	150	12	13
622 130*150*16	130	150	16	18
622 140*160*12	140	160	12	13



### 缓冲密封 ROD BUFFER SEAL

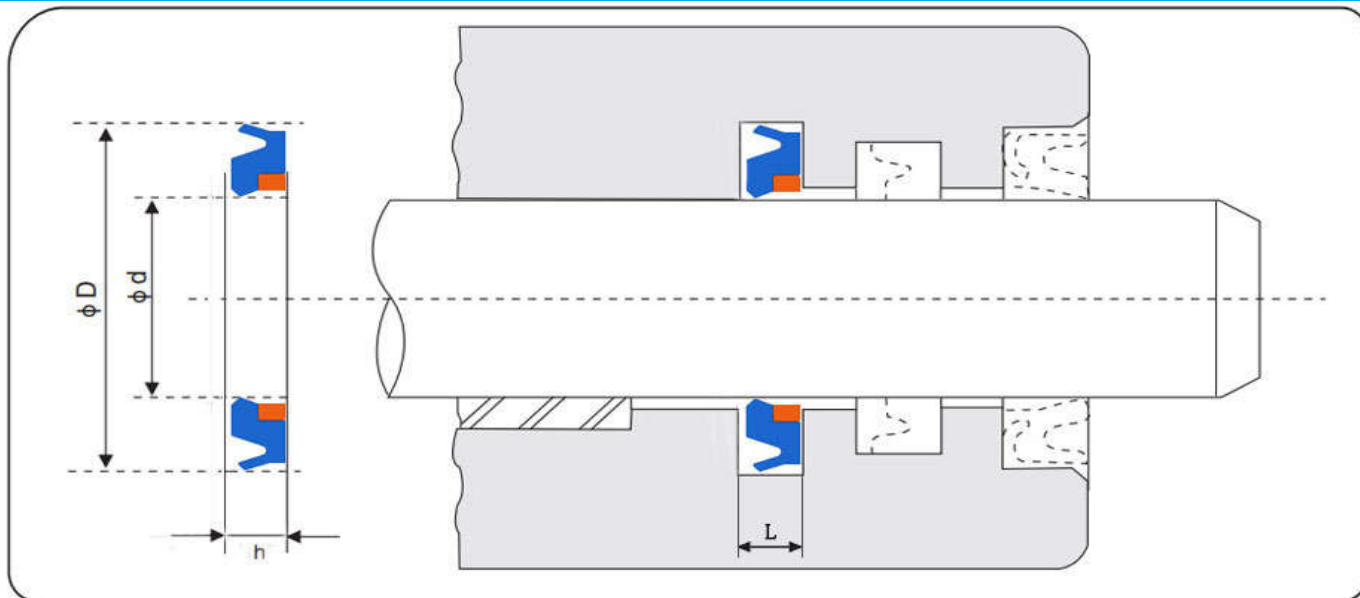

编号 Part No.	内径 \$\phi d\$	外径 \$\phi D\$	高度 h	槽宽 L
660 40*55.5*6	40	55.5	6	6.3
660 50*65.5*6	50	65.5	6	6.3
660 55*70.5*6	55	70.5	6	6.3
660 60*75.5*6	60	75.5	6	6.3
660 65*80.5*6	65	80.5	6	6.3
660 70*85.5*6	70	85.5	6	6.3
660 75*90.5*6	75	90.5	6	6.3
660 80*95.5*6	80	95.5	6	6.3
660 85*100.5*6	85	100.5	6	6.3
660 90*105.5*6	90	105.5	6	6.3
660 95*110.5*6	95	110.5	6	6.3
660 100*115.5*6	100	115.5	6	6.3
660 105*120.5*6	105	120.5	6	6.3
660 110*125.5*6	110	125.5	6	6.3
660 115*130.5*6	115	130.5	6	6.3
660 120*135.5*6	120	135.5	6	6.3
660 125*140.5*6	125	140.5	6	6.3
660 130*145.5*6	130	145.5	6	6.3

编号 Part No.	内径 \$\phi d\$	外径 \$\phi D\$	高度 h	槽宽 L

## 活塞密封 PISTON SEAL

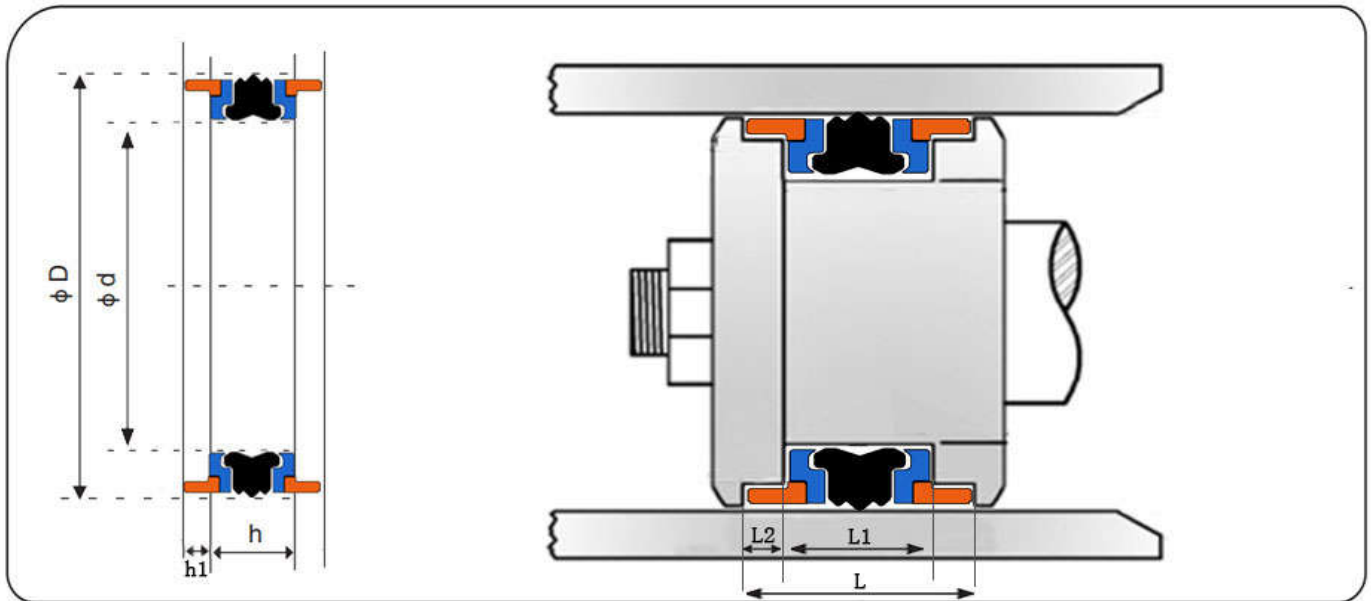

编号 Part No.	外径 øD	内径 ød	槽宽1 L1	槽宽2 L2	总高 L
780 20*11*13.5/2.1	20	11	13.5	2.1	17.7
780 25*15*12/4	25	15	12	4	20
780 25*15*12.5/4	25	15	12.5	4	20.5
780 25*16*13.5/2.1	25	16	13.5	2.1	17.7
780 30*17*15.4/6.35	30	17	15.4	6.35	28.1
780 30*21*13.5/2.1	30	21	13.5	2.1	17.7
780 32*22*15.5/2.6	32	22	15.5	2.6	20.7
780 32*22*16.4/6.35	32	22	16.4	6.35	29.1
780 32*24*15.5/3.2	32	24	15.5	3.2	21.9
780 35*25*15.5/2.6	35	25	15.5	2.6	20.7
780 35*25*16.4/6.35	35	25	16.4	6.35	29.1
780 40*24*18.4/6.35	40	24	18.4	6.35	31.1
780 40*26*15.5/2.6	40	26	15.5	2.6	20.7
780 40*30*16.4/6.35	40	30	16.4	6.35	29.1
780 40*30*12.5/4	40	30	12.5	4	20.5
780 40*30*10/5	40	30	10	5	20
780 40*30*12.5/4	40	30	12.5	4	20.5
780 40*32*15.5/3.2	40	32	15.5	3.2	21.9
780 45*29*18.4/6.35	45	29	18.4	6.35	31.1
780 45*31*15.5/2.6	45	31	15.5	2.6	20.7
780 45*35*16.4/6.35	45	35	16.4	6.35	29.1
780 50*34*18.4/6.35	50	34	18.4	6.35	31.1
780 50*34*20.5/3.1	50	34	20.5	3.1	26.7
780 50*38*20.5/4.2	50	38	20.5	4.2	28.9
780 50*40*12.5/4	50	40	12.5	4	20.5
780 55*39*18.4/6.35	55	39	18.4	6.35	31.1
780 55*39*20.5/3.1	55	39	20.5	3.1	26.7
780 55*45*12.5/4	55	45	12.5	4	20.5
780 60*44*18.4/6.35	60	44	18.4	6.35	31.1
780 60*44*20.5/3.1	60	44	20.5	3.1	26.7

编号 Part No.	外径 øD	内径 ød	槽宽1 L1	槽宽2 L2	总高 L
780 60*48*20.5/4.2	60	48	20.5	4.2	28.9
780 63*47*18.4/6.35	63	47	18.4	6.35	31.1
780 63*47*19.4/6.35	63	47	19.4	6.35	32.1
780 63*47*20.5/3.1	63	47	20.5	3.1	26.7
780 63*51*20.5/4.2	63	51	20.5	4.2	28.9
780 63*53*12.5/4	63	53	12.5	4	20.5
780 65*49*20.5/3.1	65	49	20.5	3.1	26.7
780 65*50*18.4/6.35	65	50	18.4	6.35	31.1
780 65*53*20.5/4.2	65	53	20.5	4.2	28.9
780 70*50*22.4/6.35	70	50	22.4	6.35	35.1
780 70*54*20.5/3.1	70	54	20.5	3.1	26.7
780 70*58*20.5/4.2	70	58	20.5	4.2	28.9
780 75*55*22.4/6.35	75	55	22.4	6.35	35.1
780 75*59*20.5/3.1	75	59	20.5	3.1	26.7
780 75*63*20.5/4.2	75	63	20.5	4.2	28.9
780 80*60*22.4/6.35	80	60	22.4	6.35	35.1
780 80*60*25/6.3	80	60	25	6.3	37.6
780 80*62*22.5/3.6	80	62	22.5	3.6	29.7
780 80*65*20/5	80	65	20	5	30
780 80*66*22.5/5.2	80	66	22.5	5.2	32.9
780 85*65*22.4/6.35	85	65	22.4	6.35	35.1
780 90*70*22.4/6.35	90	70	22.4	6.35	35.1
780 90*72*22.5/3.6	90	72	22.5	3.6	29.7
780 90*76*22.5/5.2	90	76	22.5	5.2	32.9
780 95*75*22.4/6.35	95	75	22.4	6.35	35.1
780 100*75*22.4/6.35	100	75	22.4	6.35	35.1
780 100*80*25/6.3	100	80	25	6.3	37.6
780 100*82*22.5/3.6	100	82	22.5	3.6	29.7
780 100*85*20/5	100	85	20	5	30
780 100*86*22.5/5.2	100	86	22.5	5.2	32.9

活塞密封  
PISTON SEAL

编号 Part No	外径 øD	内径 ød	槽宽1 I1	槽宽2 I2	总高 I
780 105*80*22.4/6.35	105	80	22.4	6.35	35.1
780 110*85*22.4/6.35	110	85	22.4	6.35	35.1
780 110*92*22.5/3.6	110	92	22.5	3.6	29.7
780 115*90*22.4/6.35	115	90	22.4	6.35	35.1
780 120*95*22.4/6.35	120	95	22.4	6.35	35.1
780 120*106*22.5/5.2	120	106	22.5	5.2	32.9
780 125*100*25.4/6.35	125	100	25.4	6.35	38.1
780 125*103*26.5/5.1	125	103	26.5	5.1	36.7
780 125*105*25/6.3	125	105	25	6.3	37.6
780 130*105*25.4/9.5	130	105	25.4	9.5	44.4
780 130*105*25.4/6.35	130	105	25.4	6.35	38.1
780 135*110*25.4/9.5	135	110	25.4	9.5	44.4
780 140*115*25.4/9.5	140	115	25.4	9.5	44.4
780 140*115*25.4/6.35	140	115	25.4	6.35	38.1
780 145*120*25.4/9.5	145	120	25.4	9.5	44.4
780 150*125*25.4/9.5	150	125	25.4	9.5	44.4
780 150*125*25.4/6.35	150	125	25.4	6.35	38.1
780 155*130*25.4/9.5	155	130	25.4	9.5	44.4
780 160*130*25.4/9.5	160	130	25.4	9.5	44.4
780 160*130*25.4/6.35	160	130	25.4	6.35	38.1
780 160*135*25.4/9.5	160	135	25.4	9.5	44.4
780 160*143*26.5/7.2	160	143	26.5	7.2	40.9
780 165*140*25.4/9.5	165	140	25.4	9.5	44.4
780 170*145*25.4/12.7	170	145	25.4	12.7	50.8
780 175*150*25.4/12.7	175	150	25.4	12.7	50.8
780 180*150*35.4/6.35	180	150	35.4	6.35	48.1
780 180*155*25.4/12.7	180	155	25.4	12.7	50.8
780 185*160*25.4/12.7	185	160	25.4	12.7	50.8
780 190*165*25.4/12.7	190	165	25.4	12.7	50.8
780 195*170*25.4/12.7	195	170	25.4	12.7	50.8
780 200*175*25.4/12.7	200	175	25.4	12.7	50.8
780 210*185*25.4/12.7	210	185	25.4	12.7	50.8
780 220*195*25.4/12.7	220	195	25.4	12.7	50.8
780 230*205*25.4/12.7	230	205	25.4	12.7	50.8
780 240*215*25.4/12.7	240	215	25.4	12.7	50.8
780 250*225*25.4/12.7	250	225	25.4	12.7	50.8

编号 Part No	外径 øD	内径 ød	槽宽1 I1	槽宽2 I2	总高 I

# CTC-SPG

卡特英制油封  
CAT INCH SEAL

### Material 材质

PTFE+NBR  
四氟+丁腈橡胶



编号 Part No.	OD B	ID A	GH D
CTC-5J7004	2	1.625	0.192
CTC-1U3998	2.25	1.875	0.192
CTC-8J6213	2.5	2.125	0.192
CTC-5J7010	2.75	2.375	0.192
CTC-6J1972	3	2.46	0.192
CTC-6J0793	3.25	2.71	0.192
CTC-5J7013	3.5	2.96	0.192
CTC-5J8011	3.75	3.21	0.192
CTC-5J5402	4	3.335	0.252
CTC-5J7854	4.25	3.585	0.252
CTC-5J4986	4.5	3.835	0.252
CTC-5J4987	4.75	4.085	0.252
CTC-5J5020	5	4.225	0.379
CTC-5J7234	5.25	4.475	0.379
CTC-5J4988	5.5	4.725	0.379
CTC-5J4989	6	5.095	0.379
CTC-5J4990	6.25	5.345	0.379
CTC-5J4991	6.5	5.595	0.379
CTC-5J4997	7	6.095	0.379
CTC-5J4993	7.25	6.345	0.379
CTC-5J7117	7.5	6.595	0.379
CTC-5J7016	7.75	6.845	0.379
CTC-5J5559	8.25	7.255	0.379
CTC-6J9385	8.5	7.505	0.379
CTC-5J7019	9.25	8.255	0.379

编号 Part No.	OD B	ID A	GH D

# CTC-SPA

卡特英制油封  
CAT INCH SEAL



编号 Part No.	OD B	ID A	GH D
CTC-1665295	2.75	2.375	0.192
CTC-9X7337	3	2.46	0.192
CTC-4T8054	3.5	2.96	0.192
CTC-9X7274	3.75	3.21	0.192
CTC-8C9160	4	3.335	0.252
CTC-8C9164	4.25	3.585	0.252
CTC-4T5172	4.5	3.835	0.502
CTC-9X7269	4.5	3.835	0.252
CTC-4T8588	4.75	4.09	0.252
CTC-8T1787	5	4.225	0.629
CTC-9X7264	5	4.225	0.379
CTC-8T0763	5.25	4.475	0.379
CTC-1546744	5.375	4.6	0.379
CTC-4T5173	5.5	4.725	0.629
CTC-6E0465	5.5	4.725	0.379
CTC-2462896	5.75	4.975	0.379
CTC-4T4144	6	5.095	0.629
CTC-8T1788	6.25	5.345	0.629
CTC-4T8695	6.5	5.595	0.629
CTC-8T1789	7	6.095	0.629
CTC-8T1790	7.25	6.345	0.629
CTC-8T1791	7.5	6.595	0.625
CTC-8T1792	7.75	6.845	0.629
CTC-8T1793	8.25	7.255	0.629
CTC-9T0119	8.5	7.505	0.629
CTC-4T4143	9.25	8.255	0.379
CTC-8T1794	10	8.88	0.69
CTC-8T1796	10.5	9.38	0.69
CTC-8T1797	11.5	10.38	0.69
CTC-1921453	12.5	11.38	0.69

编号 Part No.	OD B	ID A	GH D

# CTC-UBS

卡特英制油封  
CAT INCH SEAL

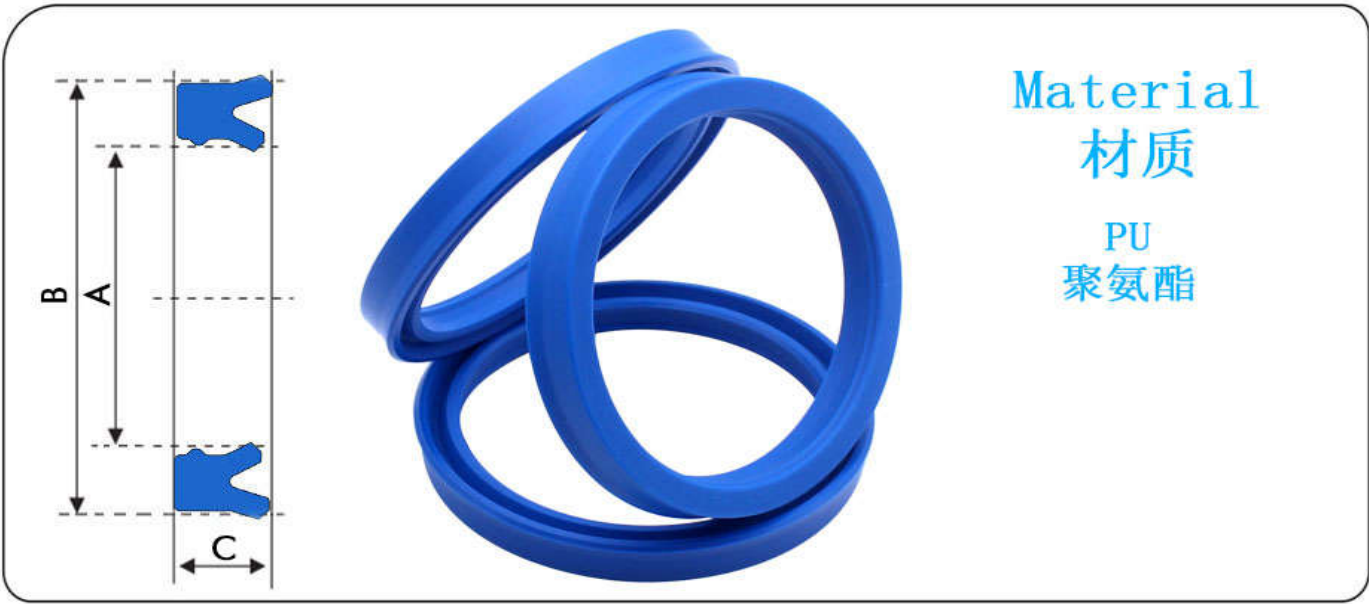

编号 Part No.	ID A	OD B	GH D
CTC-5J8150	1.5	1.875	0.25
UBS-1.5-2-0.375	1.5	2	0.375
CTC-5J8175	1.75	2.125	0.25
CTC-1672302	1.875	2.25	0.3125
CTC-1672305	2.125	2.625	0.375
CTC-5J8225	2.25	2.75	0.375
CTC-3G2911	2.375	2.875	0.375
CTC-5J0964	2.5	3	0.375
CTC-1672317	2.75	3.25	0.375
CTC-5J8200	2	2.5	0.375
CTC-5J8300	3	3.5	0.375
CTC-5J8325	3.25	3.75	0.375
CTC-3119317	3.5	4	0.375
CTC-5J8375	3.75	4.25	0.375
CTC-6J1475	4.75	5.5	0.625
CTC-3119320	4	4.625	0.375
CTC-1672345	5.75	6.5	0.625
CTC-8J4524	5	5.75	0.625

编号 Part No.	ID A	OD B	GH D

CTC-DLI

卡特英制油封  
CAT INCH SEAL



Material  
材质

PU+IRON  
聚氨酯+铁

编号 Part No.	ID A	OD B	GH D
CTC-4J8979	1.5	2.25	0.375
CTC-4J8980	1.75	2.438	0.375
CTC-1K6981	2	2.688	0.375
CTC-4J3515	2.25	3	0.375
CTC-1K6982	2.5	3.25	0.375
CTC-2J1411	3	4	0.5
CTC-6J4169	3.25	4.25	0.5

编号 Part No.	ID A	OD B	GH D

# CTC-HBI

卡特英制油封  
CAT INCH SEAL



编号 Part No.	ID A	OD B	GH D
CTC-9J3497	1.25	1.783	0.115
CTC-6J9733	1.5	2.033	0.115
CTC-6J9178	1.75	2.283	0.115
CTC-5J3616	2.25	2.891	0.188
CTC-6J6916	2.375	3.016	0.188
CTC-5J3620	2.5	3.141	0.188
CTC-6J6553	2.75	3.391	0.188
CTC-6J6917	2	2.533	0.115
CTC-6J7167	3.25	3.891	0.188
CTC-8J6070	3.75	4.391	0.188
CTC-6J6915	3	3.641	0.188
CTC-7J8943	4.25	5.225	0.218
CTC-3G5055	4.375	5.225	0.218
CTC-7J9257	4.75	5.725	0.218
CTC-8J4509	5	5.96	0.221

编号 Part No.	ID A	OD B	GH D





# CTC-DLC

## 卡特英制油封 CAT INCH SEAL

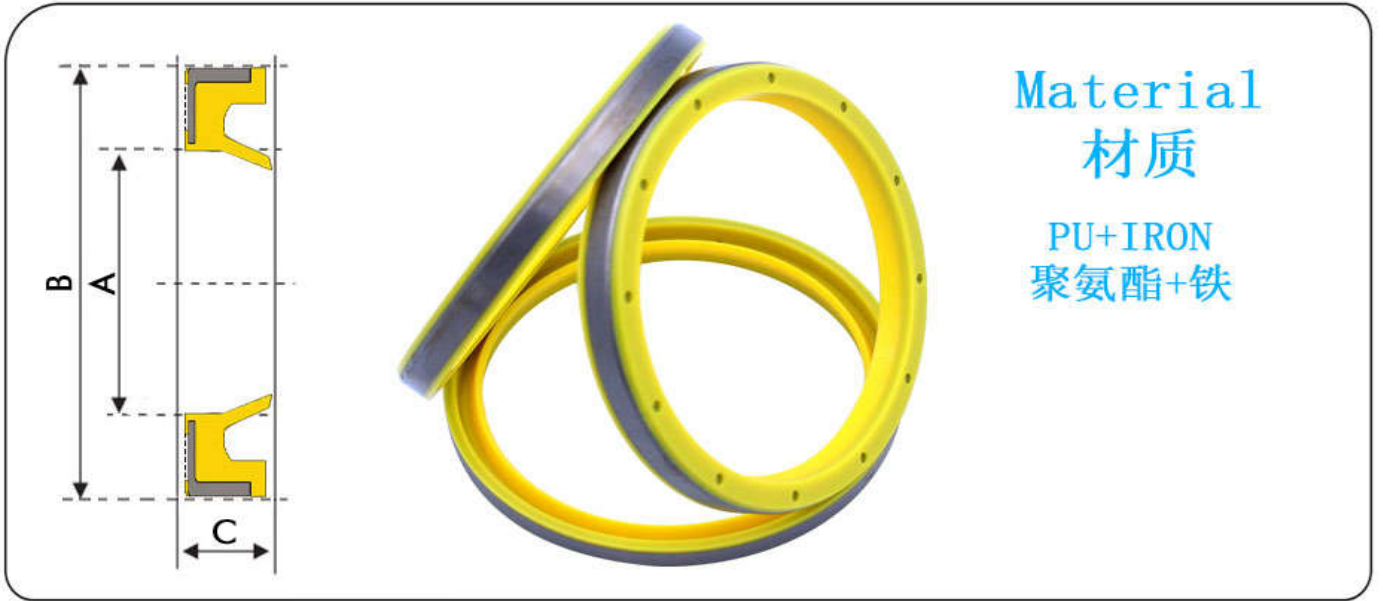

Material  
材质

PU+IRON  
聚氨酯+铁

编号 Part No.	ID A	OD B	GH D
CTC-7X4803	90	106	8
DLC-100-116-8	100	116	8
DLC-110-130-8	110	130	8
DLC-120-140-8	120	140	8
DLC-130-154-8	130	154	8
DLC-140-164-8	140	164	8

编号 Part No.	ID A	OD B	GH D
CTC-7K9201	1.5	2	0.25
CTC-7K9202	1.75	2.25	0.25
CTC-7K9203	2	2.5	0.25
CTC-7K9204	2.25	2.75	0.25
CTC-7K9205	2.5	3	0.313
CTC-7K9208	2.75	3.25	0.313
CTC-7K9209	3	3.5	0.313
CTC-7K9210	3.25	3.75	0.313
CTC-7K9211	3.5	4	0.313
CTC-7K9212	3.5	4.125	0.313
CTC-7K9218	4.5	5.25	0.313

# CTC-DKC

卡特英制油封

CAT INCH SEAL

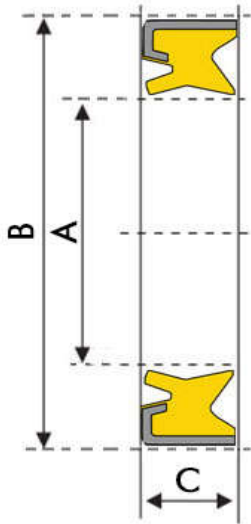

Material  
材质

PU+IRON  
聚氨酯+铁

编号 Part No.	ID A	OD B	GH D
DKC-1.25	1.25	2.25	0.433
CTC-8C9131	1.5	2.25	0.433
CTC-8C9132	1.75	2.438	0.433
CTC-9X3565	1.875	2.56	0.433
CTC-8C9133	2	2.688	0.433
CTC-9X3567	2.125	2.875	0.433
CTC-8C9134	2.25	3	0.433
CTC-9X7259	2.375	3.125	0.433
CTC-8C3840	2.5	3.25	0.433
CTC-8C3842	2.75	3.75	0.555
CTC-8C5218	3	4	0.555
CTC-8T8389	3.25	4.25	0.555
CTC-2253286	3.5	4.5	0.555
CTC-8C9135	3.75	4.75	0.555
CTC-2253288	4.25	5.25	0.555
CTC-9X7262	4.75	5.75	0.555
CTC-9X3582	5	6	0.555
CTC-2253299	8	9	0.555

编号 Part No.	ID A	OD B	GH D
CTC-2330617	45	59	8.5
CTC-2330619	50	69	11
CTC-2330625	55	74	11
CTC-2330618	60	79	11
CTC-2271148	65	84	11
CTC-2330637	80	100	14
CTC-2330622	85	105	14
DKC-90	90	110	14
CTC-2330624	95	115	14

# CTC-WRA (WR nylon)

卡特英制油封

CAT INCH SEAL

编号 Part No.	ID A	OD B	GH D
CTC-5J9073	1.5	1.25	0.485
CTC-8C9120	1.625	1.5	0.8125
CTC-8T5443	1.625	1.5	1.25
CTC-4T6907	1.875	1.75	0.98
CTC-8T6441	2	1.875	0.25
CTC-8T6442	2	1.875	0.72
CTC-4T6779	2	1.875	0.98
CTC-8T7030	2.125	2	1.25
CTC-7H2423	2.25	2	0.875
CTC-8T6682	2.25	2.125	0.36
CTC-8T6681	2.25	2.125	0.72
CTC-4T6128	2.25	2.125	0.98
CTC-8T4958	2.375	2.25	0.98
CTC-8T8204	2.375	2.25	1.1875
CTC-8J6212	2.5	2.25	0.74
CTC-9X7260	2.5	2.375	1.26
CTC-8T0785	2.625	2.5	0.98
CTC-8T5668	2.625	2.5	1.24
CTC-8T8394	2.625	2.5	1.6875
CTC-8T8365	2.7	2.5	2.28
CTC-8J0112	2.75	2.5	0.9375
CTC-8T7372	2.75	2.625	0.98
CTC-8C9114	2.875	2.75	1
CTC-6C2385	2.875	2.75	1.26
CTC-8T7849	2.875	2.75	1.5625
CTC-8T7020	2.875	2.75	1.8125
CTC-8T6743	2.95	2.75	1.96
CTC-2233353	3	2.75	0.75
CTC-6J5733	3	2.75	0.99
CTC-4T7283	3	2.75	1.24
CTC-8T6443	3	2.8	0.99
CTC-8C9161	3.125	3	0.98
CTC-9T0094	3.125	3	1.24
CTC-8T1714	3.125	3	1.5625
CTC-8T7584	3.125	3	1.65
CTC-8C9153	3.2	3	1.17
CTC-8J2577	3.25	3	0.74
CTC-8J6371	3.25	3	1.11
CTC-8T6683	3.25	3.05	1.125
CTC-2233502	3.375	3.125	0.75
CTC-8T0777	3.375	3.25	1.74
CTC-8T4813	3.45	3.25	1.625
CTC-8T6745	3.45	3.25	1.96
CTC-8T6744	3.45	3.25	2.74
CTC-7J6916	3.5	3.25	0.625
CTC-2233356	3.5	3.25	0.75
CTC-6H5496	3.5	3.25	0.875
CTC-7J9885	3.5	3.25	1.125
CTC-4J3236	3.5	3.25	1.49
CTC-8C5245	3.625	3.5	1.05
CTC-8T3329	3.625	3.5	1.875

编号 Part No.	ID A	OD B	GH D
CTC-8C3829	3.7	3.5	1.76
CTC-1324907	3.7	3.5	1.88
CTC-8T6746	3.7	3.5	2.36
CTC-2233357	3.75	3.494	0.75
CTC-8J6245	3.75	3.5	1
CTC-5J8019	3.75	3.5	1.24
CTC-6J3075	3.75	3.5	1.99
CTC-8T7848	3.875	3.75	1.57
CTC-8T3330	3.95	3.75	2.437
CTC-5J7154	4	3.75	0.61
CTC-8H0214	4	3.75	0.875
CTC-6J2797	4	3.75	0.99
CTC-6U3246	4	3.75	1
CTC-1M1571	4	3.75	1.24
CTC-3G4723	4.125	3.875	0.42
CTC-8T7538	4.2	4	1.5625
CTC-8T6747	4.2	4	2.55
CTC-4T4753	4.25	3.994	1.883
CTC-2259524	4.25	4	0.75
CTC-6J7264	4.25	4	0.99
CTC-1194760	4.25	4	1
CTC-6J4003	4.25	4	1.24
CTC-5J8157	4.25	4	1.49
CTC-7J3300	4.26	4.01	2.49
CTC-8T6748	4.45	4.25	2.375
CTC-2264162	4.5	4.244	0.75
CTC-5U3531	4.5	4.25	0.75
CTC-6H6270	4.5	4.25	0.875
CTC-4J4605	4.5	4.25	0.9375
CTC-1460744	4.5	4.25	0.98
CTC-4J3745	4.5	4.25	0.99
CTC-6U4154	4.5	4.25	1
CTC-4J2620	4.5	4.25	1.49
CTC-4J2630	4.5	4.25	1.5
CTC-4T8758	4.5	4.25	1.86
CTC-0901301	4.5	4.25	2.36
CTC-2233360	4.75	4.494	0.75
CTC-4T9248	4.75	4.5	1.24
CTC-1317184	4.75	4.5	1.645
CTC-3J7663	4.75	4.5	1.99
CTC-4T6929	4.75	4.5	3.5
CTC-8T7850	4.95	4.75	1.96
CTC-2263860	5	4.744	0.75
CTC-7J1627	5	4.75	0.85
CTC-4J4630	5	4.75	1.11
CTC-8M4226	5	4.75	1.24
CTC-4J3420	5	4.75	1.55
CTC-4T4752	5	4.75	1.75
CTC-8T3331	5.2	5	2.5
CTC-7J8878	5.25	4.5	0.187
CTC-2D0714	5.25	5	1.02

# CTC-WRA (WR nylon)

卡特英制油封

CAT INCH SEAL

编号 Part No.	ID A	OD B	GH D
CTC-9J7978	5.25	5	1.49
CTC-9J3054	5.25	5	3.61
CTC-1546747	5.375	5.125	1
CTC-4T5718	5.45	5.25	2.482
CTC-1898686	5.5	5.126	1.744
CTC-5U4278	5.5	5.25	0.75
CTC-4J4606	5.5	5.25	1.24
CTC-3J9026	5.5	5.25	1.375
CTC-7J3303	5.5	5.25	1.61
CTC-7J1731	5.5	5.25	1.74
CTC-4J3518	5.5	5.25	1.99
CTC-8J1690	5.5	5.25	2.24
CTC-9J4164	5.75	5.5	1.61
CTC-6J3074	5.75	5.5	1.99
CTC-8J9917	5.75	5.5	2.36
CTC-8T7851	5.95	5.75	1.96
CTC-8T3332	5.95	5.75	3.61
CTC-7J8877	6	5.25	0.187
CTC-4T6930	6	5.625	2.74
CTC-3G6537	6	5.75	1.0625
CTC-5J0014	6	5.75	1.24
CTC-1J0708	6	5.75	1.3125
CTC-9J5860	6	5.75	1.49
CTC-7J5326	6	5.75	1.74
CTC-8J1714	6	5.75	2.86
CTC-5J3326	6.25	6	1.49
CTC-9J5550	6.25	6	1.74
CTC-4T9319	6.25	6	2.74
CTC-7J8880	6.5	6	0.243
CTC-7J8881	6.5	6	3.485
CTC-5J0058	6.5	6.25	1.25
CTC-3J9027	6.5	6.25	1.375
CTC-3J9703	6.5	6.25	1.49
CTC-9J9806	6.5	6.25	1.74
CTC-7J1938	6.5	6.25	1.99
CTC-9J3055	6.5	6.25	2.74
CTC-7J9232	6.5	6.25	2.86
CTC-9J0811	6.5	6.25	3.48
CTC-1915604	6.75	6.434	0.99
CTC-8M4228	7	6.75	1.485
CTC-3G5098	7	6.75	1.74
CTC-9J0711	7	6.75	1.99
CTC-3G3470	7	6.75	2.36
CTC-8J1662	7	6.75	3.125
CTC-8T6749	7.2	7	3.14
CTC-1U1734	7.25	6.875	3.0625
CTC-1J2674	7.25	7	1.375
CTC-3J7848	7.25	7	1.99
CTC-4J7663	7.25	7	7.1
CTC-8T1127	7.375	7	1.61
CTC-1U2218	7.5	7.25	1.49

编号 Part No.	ID A	OD B	GH D
CTC-8J9936	7.5	7.25	2.36
CTC-9J5562	7.5	7.25	2.49
CTC-4T4811	7.5	7.25	2.95
CTC-7J8886	7.75	7.25	0.243
CTC-4T6932	7.75	7.375	4.49
CTC-9J5037	7.75	7.5	1.61
CTC-9J3624	7.75	7.5	1.99
CTC-7J9247	7.75	7.5	3.5
CTC-8T7695	8	7.75	5
CTC-6E0245	8.2	8	2.95
CTC-7J8887	8.25	7.75	0.243
CTC-4T9320	8.25	7.75	3.5
CTC-3G9882	8.25	7.875	1.99
CTC-9J8102	8.25	7.875	2.74
CTC-2J0745	8.25	8	1.25
CTC-4J7376	8.25	8	1.49
CTC-3J8683	8.25	8	1.74
CTC-8J8375	8.25	8	2.125
CTC-3J7632	8.25	8	2.24
CTC-7J3301	8.25	8	2.49
CTC-8J8826	8.25	8	2.74
CTC-9J3056	8.25	8	4.11
CTC-1476584	8.5	8.25	1.174
CTC-7J8064	8.5	8.25	2.36
CTC-8T7694	8.5	8.25	3
CTC-4T5949	9.25	9	1.962
CTC-7J2087	9.25	9	2.25
CTC-8C3846	9.374	9	8.985
CTC-4T6097	9.5	9.125	1.93
CTC-1178865	10	9.75	1.485
CTC-1214175	10	9.75	1.9
CTC-8C3843	10	9.75	2.74
CTC-9J3369	10	9.75	3.24
CTC-7J8890	10.25	9.75	0.243
CTC-2299443	10.5	10.248	2.382
CTC-9J1159	10.5	10.25	2.74
CTC-8J8900	10.5	10.25	3.74
CTC-8J5980	10.5	10.25	4
CTC-8T6637	10.75	10.375	6.49
CTC-6E0249	11	10.75	1.923
CTC-9J2991	11.5	11.25	3.875
CTC-4T6096	12.25	11.875	4
CTC-1U2694	12.493	12.243	3.994
CTC-6E0308	12.5	12.24	1.46
CTC-1530119	12.75	12.5	3.987
CTC-8T1130	12.875	12.5	2.89
CTC-4T4827	12.875	12.5	12.18
CTC-1U4627	13.118	12.744	7.854
CTC-6E0247	13.75	13.5	4.009
CTC-4T4129	14.25	14	3.993
CTC-9X3564	16.118	15.744	7.696









# ORING KIT

O型圈盒  
ORING KIT

